

INFORMAZIONI GENERALI

Il presente catalogo serve per richiedere con esattezza le parti di ricambio
Nelle ordinazioni indicare:

- 1) il numero di codice dei particolari seguito dalla descrizione;
- 2) il colore per i pezzi verniciati o comunque colorati;
- 3) il numero di matricola del motociclo, stampigliato sul canotto di sterzo.

Le indicazioni destra e sinistra si riferiscono ai lati del veicolo rispetto al senso di marcia.

GENERAL INFORMATION

The present spare parts list enables one to order exactly the right spare parts.

When ordering specify:

- 1) the part's code number followed by its description;
- 2) indicate colour for painted or coloured parts;
- 3) the motorcycle's serial number, stamped on the steering head.

References to right and left apply to the vehicle in terms of its direction of movement.

INFORMATIONS GENERALES

Ca catalogue permet de commander correctement les pièces de rechange.

Les commandes doivent être passées en indiquant:

- 1) le numéro de code des pièces détachées suivi de leur description;
- 2) le couleur des pièces peintes ou colorés;
- 3) le matricule de la moto, estampillé sur la tige du guidon.

Droite et gauche sont les côtés du véhicule par rapport au sens de la marche.

ALLGEMEINE HINWEISE

Dieser Ersatzteilkatalog dient zur genauen Angabe der Teile bei Ersatzteilbestellungen.

Bei Ersatzbestellung ist folgendes anzugeben:

- 1) Die Bestellnummer der Ersatzteile mit der entsprechenden Beschreibung;
- 2) Farbe für lackierte und farbige Teile angeben;
- 3) Die Sseriennummer des Motorrrads, die am Lenkrohr eingepägt ist. Die Angaben rechts und links beziehen sich auf das Fahrzeug in Fahrriichtung.

INFORMACIONES GENERALES

El presente catálogo sirve para pedir con exactitud las partes de recambio. En los pedidos se debe indicar:

- 1) el número de código de la parte y a continuación la descripción;
- 2) el color para las piezas barnizadas o coloreadas;
- 3) el número de matrícula de la motocicleta, estampado en le tubo de dirección.

Las indicaciones derecha e izquierda se refieren a los lados del vehículo respecto del sentido de marcha.

NOTE - LIST - NOTES - NOTE - NOTAS:

- A : In alternativa - In alternative - En alternative - Wahlweise
En alternativa
- C : Modello CR- CR model - Modéle CR - Modell CR
Modélo CR
- D : In dotazione - To issue - En necessaire - Ausrüstungsteile
En dotaciòn
- E : Ad esaurimento - To fell out - A' finir - Erschöpfung
A agotamiento
- F : Fornire assieme - Supply unitedly - Fournir ensemble
Wird zusammen geliefert - Equipar juntos
- N : Non fornito - Not supplied - Ne pas fournir
Keine Gelieferende - No equiparado
- R : A richiesta - Upon request - Sur demande - Auf anfrage
Bajo pedido
- S : Di serie - Supplied - De sèrie - Standard - De serie
- U : Solo per WR/ U.S.A. - Only for WR/ U.S.A. - Soulement pour
WR/ U.S.A. - Nur für WR/ U.S.A. - Solo por WR/ U.S.A.
- X : Non per U.S.A. - Not for U.S.A. - Ne pas pour U.S.A.
Keine für U.S.A. - No por U.S.A.
- XBR : Non per Brasile- Not for Brazil - Ne pas pour Brasile
Keine für Brasilien - No por Brasil
- Y : Non per CR- Not for CR- Ne pas pour CR - Keine für CR
No por CR
- W : Modello WR- WRmodel - Modéle WR- Modell WR
Modélo WR
- Z : n° denti, number of teeth, numéro dents, Zähne nummer
número dientes

- A : Austria, Austria, Autriche, Österreich, Austria
- AUS : Australia, Australia, Australie, Australien, Australia
- B : Belgio, Belgium, Belgique, Belgien, Bélgica
- BR : Brasile, Brazil, Brasile, Brasilien, Brasil
- CDN : Canada, Canada, Canada, Kanada, Canadá
- CH : Svizzera, Switzerland, Suisse, Schweizer, Suiza
- D : Germania, Germany, Allemagne, Deutschland, Alemania
- E : Spagna, Spain, Espagne, Spanien, España
- F : Francia, France, France, Frankreich, Francia
- GB : Gran Bretagna, Great Britain, Grand Bretagne, Groos Britan,
Gran Bretaña
- I : Italia, Italy, Italie, Italien, Italia
- J : Giappone, Japan, Japon, Japan, Japón
- SF : Finlandia, Finald, Finlande, Finland, Finlandia
- USA : Stati Uniti d'America, United States of America, Etats Units
d'Amérique, Vereinigte Staaten von Amerika
Estados Unidos

Il n° di matricola iniziale del modello WR 250/2004 è ZCG3H00AB3V002374
Il n° di matricola iniziale del modello CR 250/2004 è ZCG3H00AB3V051062

The initial serial number for the WR 250/2004 model is
ZCG3H00AB4V002374

The initial serial number for the CR 250/2004 model is
ZCG3H00AB4V051062

Le matricule initial du modèle WR 250/2004 est ZCG3H00AB4V002374
Le matricule initial du modèle CR 250/2004 est ZCG3H00AB4V051062

Die Seriennummer des Modells WR 250/2004 beginnt mit
ZCG3H00AB4V002374

Die Seriennummer des Modells CR 250/2004 beginnt mit
ZCG3H00AB4V051062

El n° de matrícula inicial de la motocicleta WR 250/2004 es
ZCG3H00AB4V002374

El n° de matrícula inicial de la motocicleta CR 250/2004 es
ZCG3H00AB4V051062

Dati indicativi soggetti a modifiche senza impegno di preavviso.
All data are subject to modification without prior notice.
Données indicatif sujet au modifications sans obligation de préavis.
Änderungen Vorbehalten.
Datos indicativos sujetos a modificaciones sin compromiso de preaviso.

Tavola Drawing Table Bild Tabla	Denominazione	Description	Designation	Bezeichnung	Denominacion	Pagina Page Page Seite Paja
1	ATTREZZI DI ASSISTENZA, MANUALI E CATALOGHI	SERVICE TOOLS, MANUALS AND CATALOGS	OUTILS D'ASSISTANCE, MANUELS ET CATALOGUES	HILFAUSRUSTUNG, HANDBUCH UND KATALOG	HERRAMIENTAS DE ASISTENCIA, MANUALES Y CATALOGOS	11
2	TESTA, CILINDRO, PISTONE, MANOVELLISMO	CYLINDER HEAD, CYLINDER, PISTON, CRANKSHAFT	CULASSE, CYLINDRE, PISTON, VILEBREQUIN	ZYLINDERKOPF, ZYLINDER, KOLBEN, KURBELWELLE	CULATA, CILINDRO, PISTON, PALANCAS	13
3	H.T.S.	H.T.S.	H.T.S.	H.T.S.	H.T.S.	19
4	RAFFREDDAMENTO	COOLING	REFROIDISSEMENT	WASSERKÜHLUNG	ENFRIAMIENTO	23
5	BASAMENTO	CRANKCASE	CARTER	GEHAUSE	BANCADA	25
6	COPERCHI BASAMENTO	CRANKCASE COVERS	COUVERCLES CARTER	GEHAUSEDECKEL	TAPA BANCADA	29
7	AVVIAMENTO A PEDALE	KICK STARTER	PEDAL DE MISE EN MARCHÉ	ANLASSER	PUESTA EN MARCHA A PEDAL	31
8	FRIZIONE, TRASM. PRIMARIA	CLUTCH, PRIMARY DRIVE	EMBAYAGE, TRANSMISS. PRIMARIE	KUPPLUNG, ERSTERANTRIEB	EMBRAGUE, TRANSM. PRIMARIA	35
9	CAMBIO	TRANSMISSION	BOITE DE VITESSE	WECHSELGETRIEBE	CAMBIO	37
10	COMANDO CAMBIO	SHIFTER	COMMANDE DE VITESSE	GANGSCHALTUNG	MANDO CAMBIO	39
11	PARTE ELETTRICA	ELECTRIC PART	PARTIE ELECTRIQUES	ELEKTRISCHE TEILE	PARTE ELECTRICA	41
12	CARBURATORE	CARBURETOR	CARBURATEUR	VERGASER	CARBURADOR	43
13	FILTRO ARIA	AIR FILTER	FILTRE AIRE	AIRFILTER	FILTRO DE AIRE	47
14	TELAIO, PEDANE	FRAME, FOOT RESTS	CADRE, REPOSE PIEDS	RAHMEN, FUSSBRETT	BASTIDOR, REPOSAPIES	49
15	SOSPENSIONE ANTERIORE	FRONT FORK ASSEMBLY	SUSPENSION AVANT	VORDERTELESKOPGABEL	SUSPENSION DELANTERA	53
16	FORCELLONE	SWING ARM	FOURCHE	GABEL	HORQUILLA	59
16A	LEVERAGGI SOSPENSIONE POSTERIORE	REAR SUSPENSION LINKAGE	LEVIER SUSPENSION ARRIERE	HEBELWERK HINTERHAUFHANGUNG	PALANCA SUSPENSION TRASERA	63
16B	AMMORTIZZATORE POSTERIORE	REAR SUSPENSION	SUSPENSION ARRIERE	HINTERHAUFHANGUNG	SUSPENSION TRASERA	65
17	MANUBRIO E COMANDI	HANDLEBAR AND CONTROLS	GUIDON ET COMMANDES	LENKER UND STEUERORGANE	MANILLAR Y MANDOS	67
18	FRENO IDRAULICO POSTERIORE	REAR HYDRAULIC BRAKE	FREIN HYDRAULIQUE ARRIERE	HINTERBREMSE	FRENO HIDRAULICO TRASERO	69
19	PANNELLI LAT., PARAFANGHI, SELLA	SIDE PANELS, FENDERS, SEAT	PANNEAU, GARDE-BOUES, SIEGE	STREIFEN, KOTFLUGEL, SATTEL	PANELES, GUARDABARROS, SILLIN	73
20	SERBATOIO CARBURANTE, CONVOGIATORI	GAS TANK, PANELS	RESERVOIR CARBURANT, FLANCS	KRAFTSTOFFBEHALTER, FLANKE	DEPOSITO GASOLINA, LATERALES	75
21	SCARICO	EXHAUST SYSTEM	TUYAU D'ÉCHAPPEMENT	AUSPUFFROHR	TUBO DE ESCAPE	77
22	FRENO IDRAULICO ANTERIORE	FRONT HYDRAULIC BRAKE	FREIN HYDRAULIQUE AVANT	VORTERBREMSE	FRENO HIDRAULICO DELANTERA	79
22A	RUOTA ANTERIORE	FRONT WHEEL	ROUE AV.	VORTERRAD	RUEDA DELANTERA	81
23	RUOTA POSTERIORE	REAR WHEEL	ROUE ARRIERE	HINTERRAD	RUEDA TRASERA	83
24	STRUMENTO DIGITALE (WR)	DIGITAL INSTRUMENT (WR)	INSTRUMENT DIGITAL (WR)	DIGITAL TACHOMETER (WR)	INSTRUMENTO DIGITAL (WR)	87

Tavola Drawing Table Bild Tabla	Denominazione	Description	Designation	Bezeichnung	Denominacion	Pagina Page Page Seite Paja
25	IMPIANTO ELETTRICO, PORTATARGA, PORTAFARO ANTERIORE (WR)	ELECTRIC SYSTEM, PLATE HOLDER, HEADLAMP FAIRING (WR)	INSTALLATION ELECT., PORTE-BALAI, DOME PORTE PHARE (WR)	ELEKTR. ANLAGE, SCHILDTRAEGER, HUBE SCHEINWI-HALTER (WR)	INSTALAC. ELECT., PORTA-MATRICULA CASQUETE PORTAFARO (WR)	89
26	INDICATORI DI DIREZIONE, AVVISATORE ACUSTICO (WR)	BLINKERS, HORN (WR)	CLIGNOTANTS, SIGNAL ACOUSTIQUE (WR)	BLINKERS, HUPE (WR)	INTERMITENTES, AVISADOR ACUSTICO (WR)	93
27	KIT TRASFORMAZIONE ENDURO (WR U.S.A.)	ENDURO TRANSFORMATION KIT (WR U.S.A.)	SET TRANSFORMATION ENDURO (WR U.S.A.)	KIT TRANSFORMATION ENDURO (WR U.S.A.)	KIT TRANSFORMATION ENDURO (WR U.S.A.)	95
28	DECALCOMANIE (WR)	TRANSFER (WR)	DECALCOMANIE (WR)	ABZIEHBILD (WR)	CALCOMANIA (WR)	99
29	DECALCOMANIE (CR, WR-USA)	TRANSFER (CR, WR-USA)	DECALCOMANIE (CR, WR-USA)	ABZIEHBILD (CR, WR-USA)	CALCOMANIA (CR, WR-USA)	101
-	INDICE NUMERICO PROGRESSIVO	NUMERICAL INDEX	INDEX NUMERIQUE	NUMMERNVERZEICHNIS	ÍNDICE NUMÉRICO PROGRESIVO	102

Tavola - Drawing - Table - Bild - Tabla

1

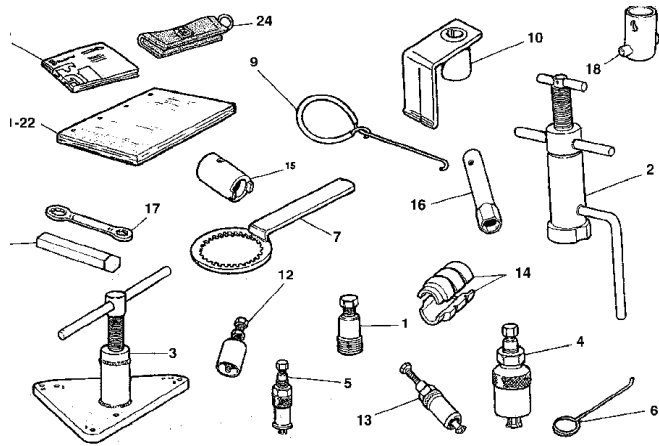

Pagina - Page - Page - Seite - Paja

10

Tavola - Drawing - Table - Bild - Tabla

2

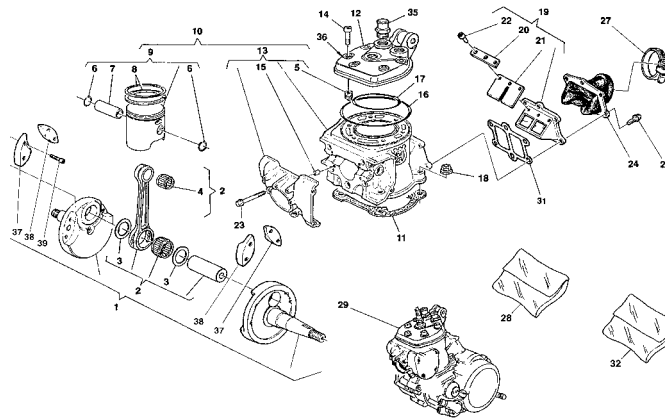

Pagina - Page - Page - Seite - Paja

12

Tavola - Drawing - Table - Bild - Tabla

3

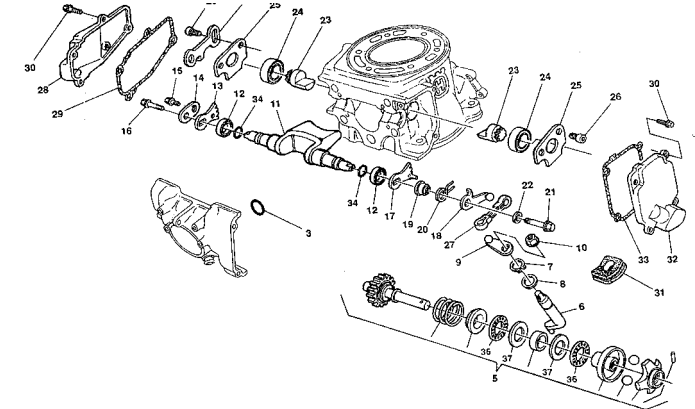

Pagina - Page - Page - Seite - Paja

18

Tavola - Drawing - Table - Bild - Tabla

4

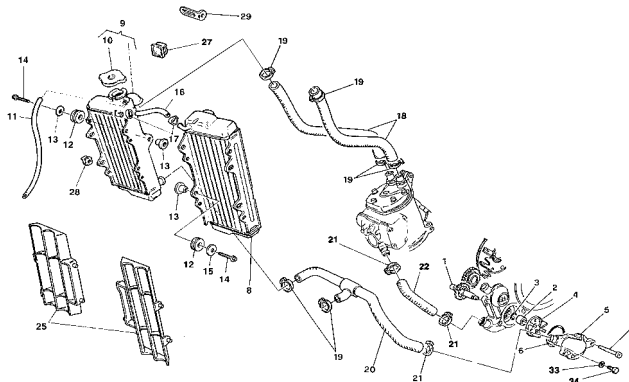

Pagina - Page - Page - Seite - Paja

22

Tavola - Drawing - Table - Bild - Tabla

5

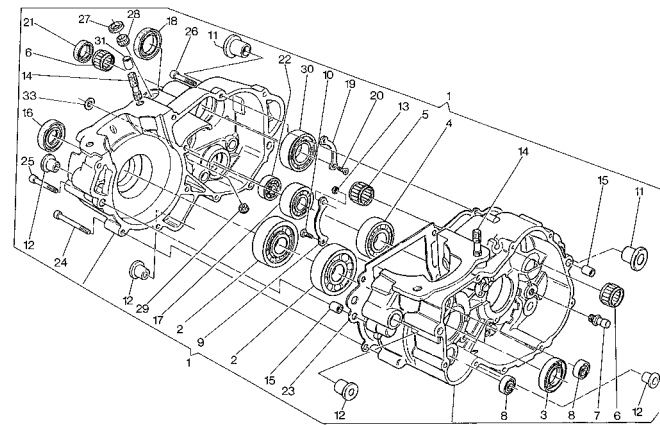

Pagina - Page - Page - Seite - Paja

24

Tavola - Drawing - Table - Bild - Tabla

6

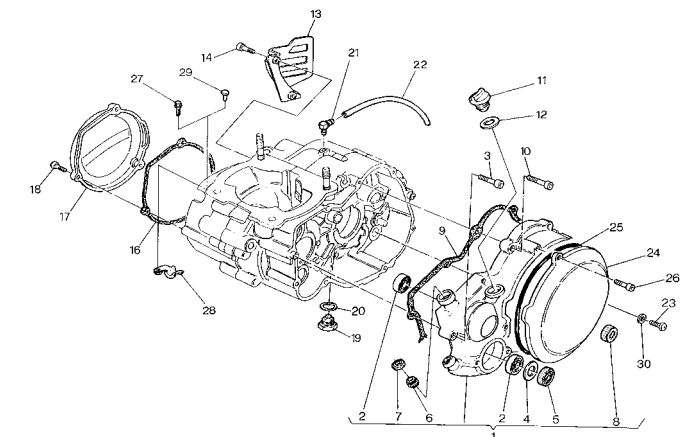

Pagina - Page - Page - Seite - Paja

28

Tavola - Drawing - Table - Bild - Tabla

7

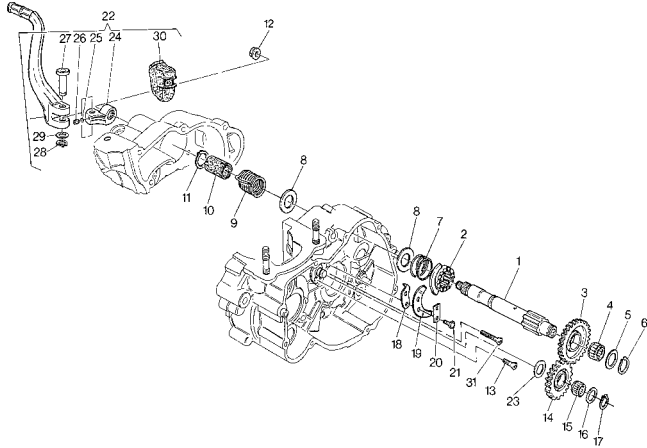

Pagina - Page - Page - Seite - Paja

30

Tavola - Drawing - Table - Bild - Tabla

8

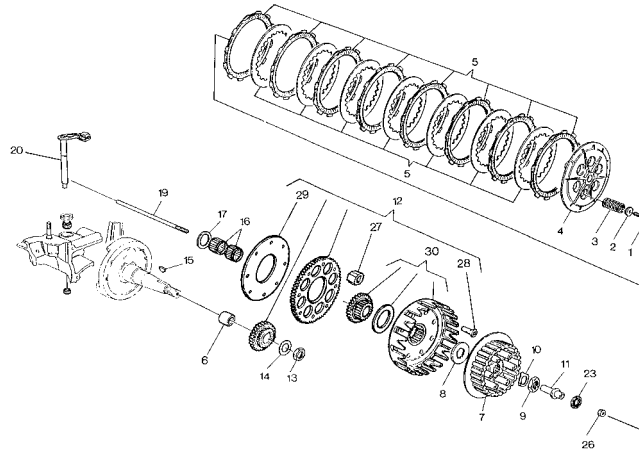

Pagina - Page - Page - Seite - Paja

34

Tavola - Drawing - Table - Bild - Tabla

9

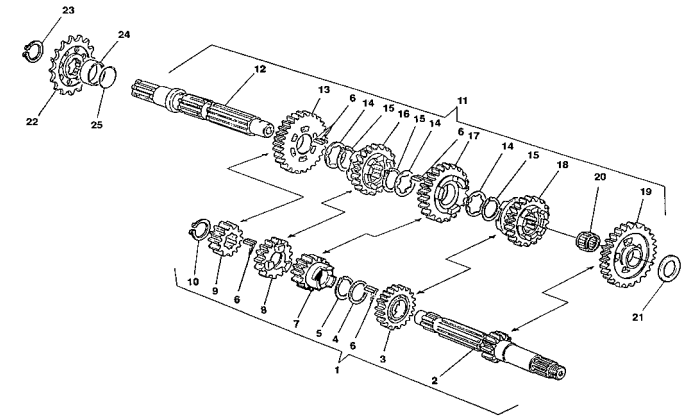

Pagina - Page - Page - Seite - Paja

36

Tavola - Drawing - Table - Bild - Tabla

10

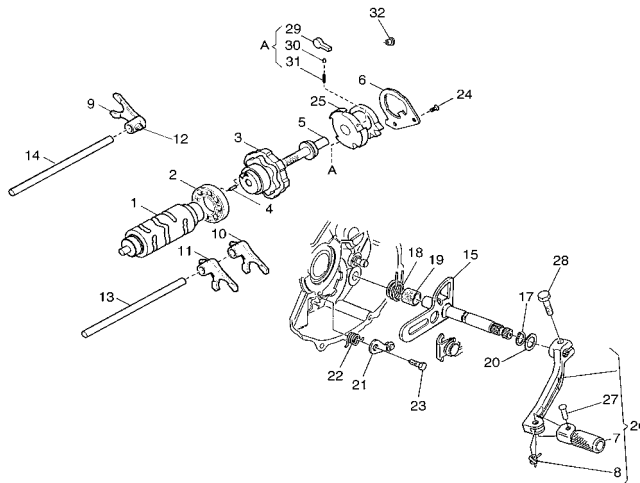

Pagina - Page - Page - Seite - Paja

38

Tavola - Drawing - Table - Bild - Tabla

11

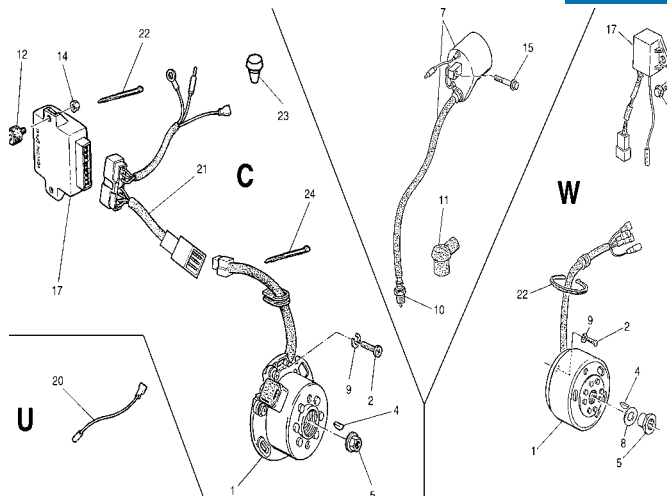

Pagina - Page - Page - Seite - Paja

40

Tavola - Drawing - Table - Bild - Tabla

12

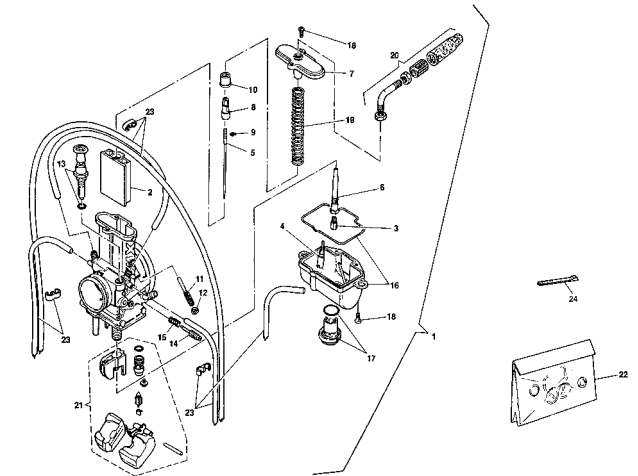

Pagina - Page - Page - Seite - Paja

42

Tavola - Drawing - Table - Bild - Tabla

13

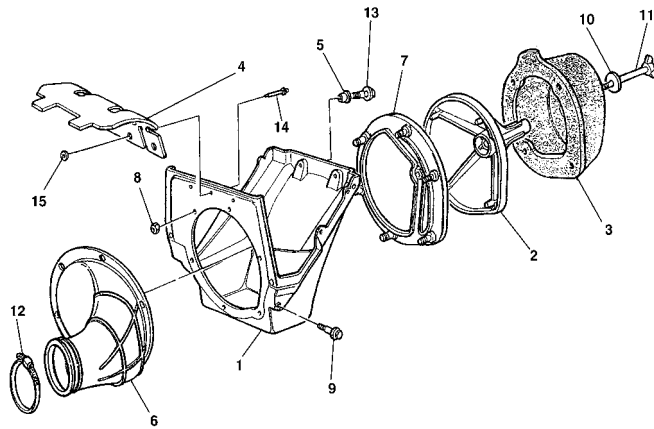

Pagina - Page - Page - Seite - Paja

46

Tavola - Drawing - Table - Bild - Tabla

14

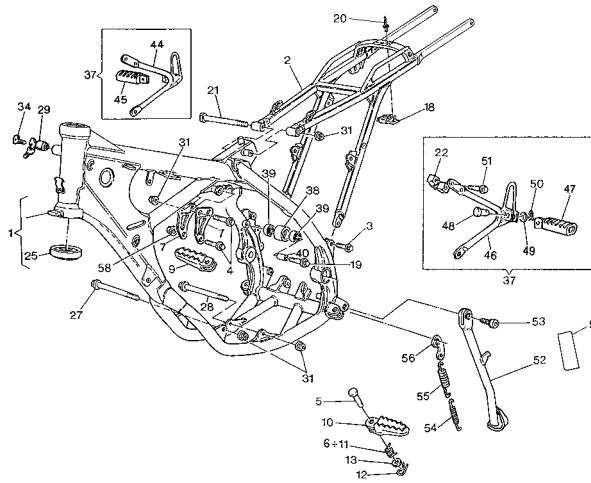

Pagina - Page - Page - Seite - Paja

48

Tavola - Drawing - Table - Bild - Tabla

15

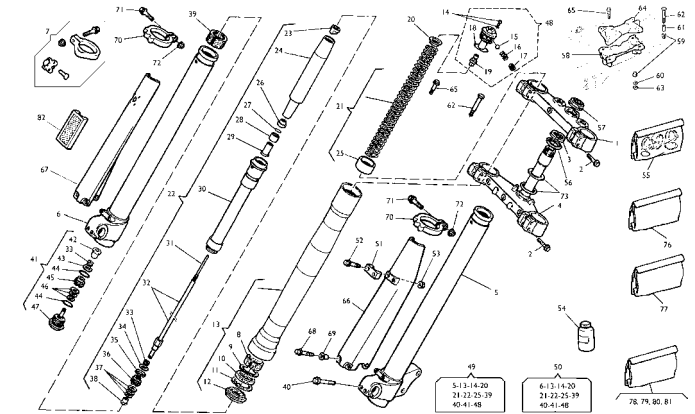

Pagina - Page - Page - Seite - Paja

52

Tavola - Drawing - Table - Bild - Tabla

16

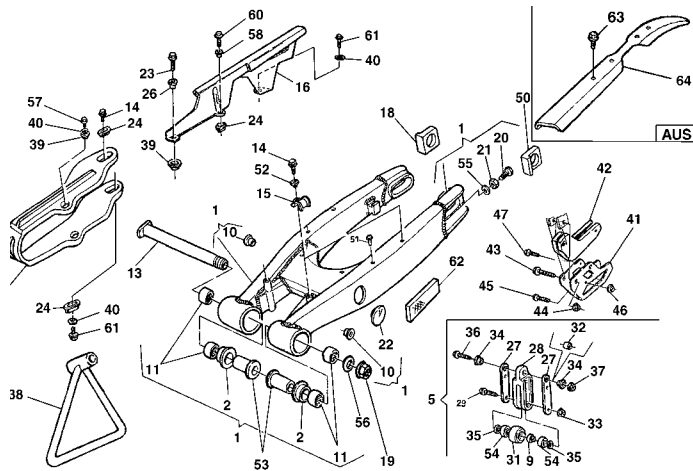

Pagina - Page - Page - Seite - Paja

58

Tavola - Drawing - Table - Bild - Tabla

16A

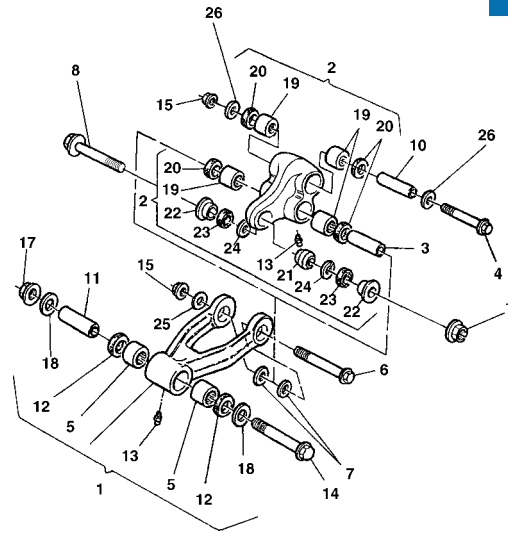

Pagina - Page - Page - Seite - Paja

62

Tavola - Drawing - Table - Bild - Tabla

16B

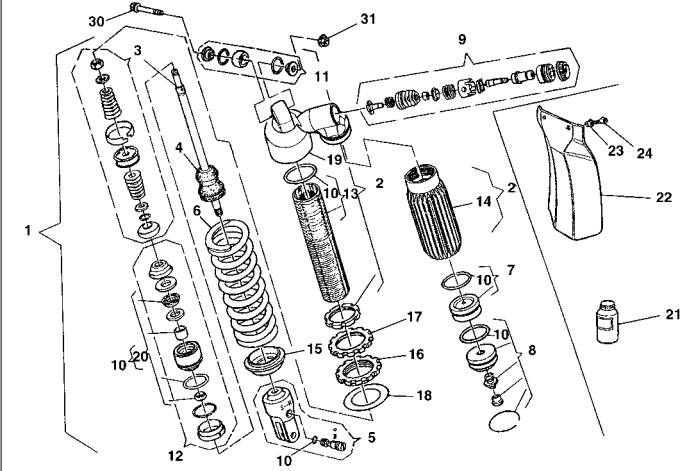

Pagina - Page - Page - Seite - Paja

64

Tavola - Drawing - Table - Bild - Tabla

17

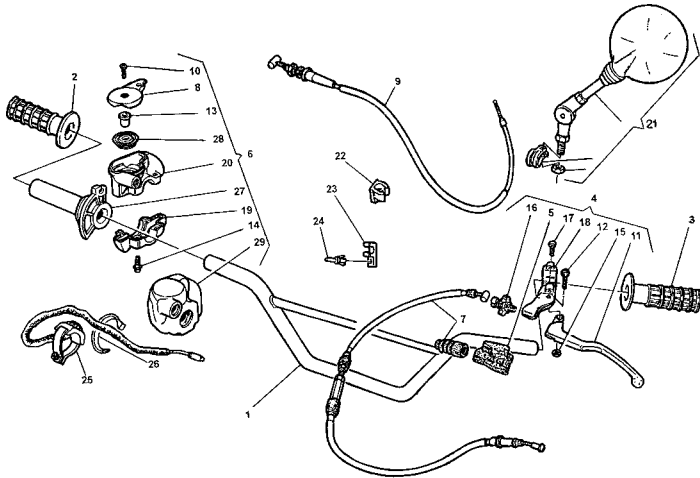

Pagina - Page - Page - Seite - Paja

66

Tavola - Drawing - Table - Bild - Tabla

18

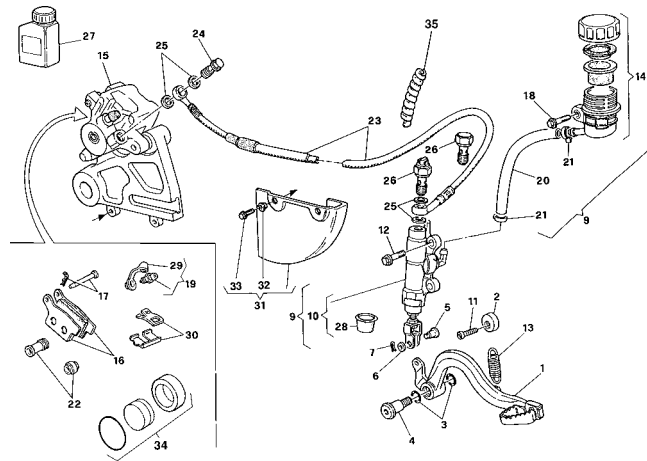

Pagina - Page - Page - Seite - Paja

68

Tavola - Drawing - Table - Bild - Tabla

19

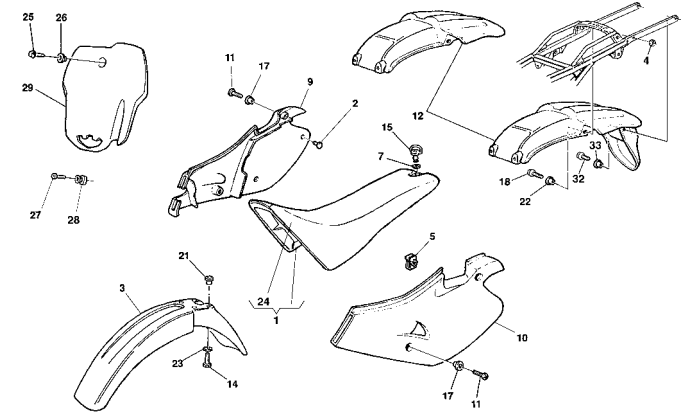

Pagina - Page - Page - Seite - Paja

72

Tavola - Drawing - Table - Bild - Tabla

20

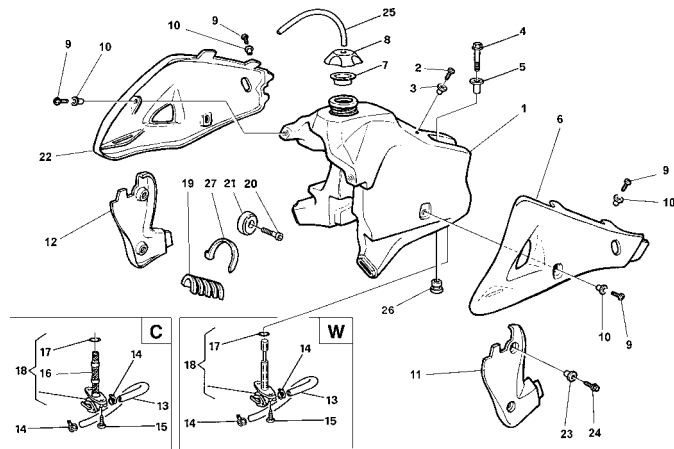

Pagina - Page - Page - Seite - Paja

74

Tavola - Drawing - Table - Bild - Tabla

21

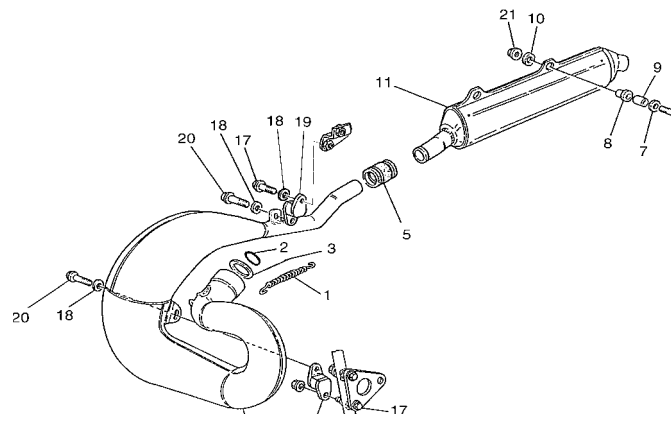

Pagina - Page - Page - Seite - Paja

76

Tavola - Drawing - Table - Bild - Tabla

22

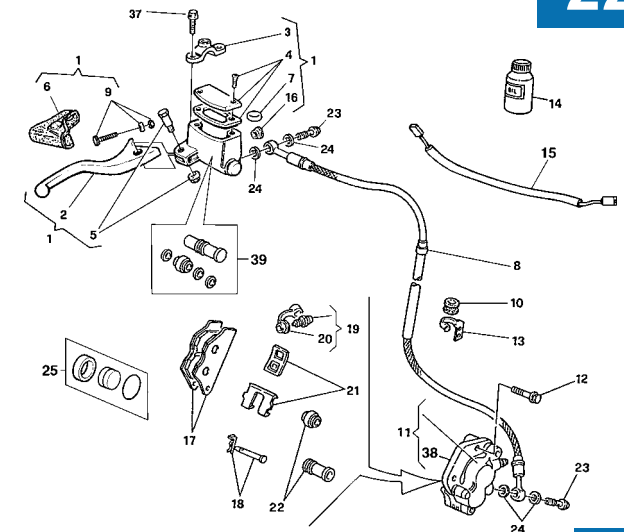

Pagina - Page - Page - Seite - Paja

78

Tavola - Drawing - Table - Bild - Tabla

22A

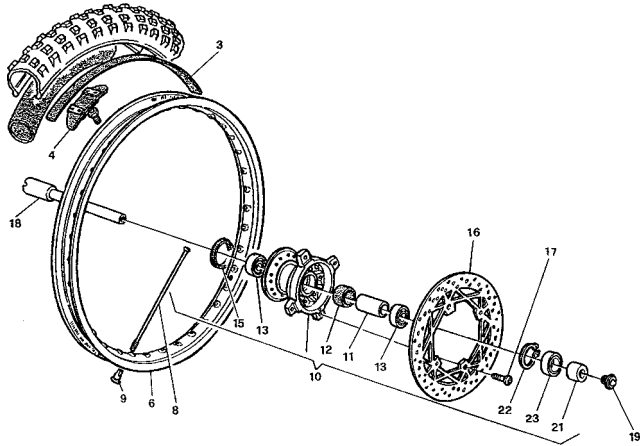

Pagina - Page - Page - Seite - Paja

80

Tavola - Drawing - Table - Bild - Tabla

23

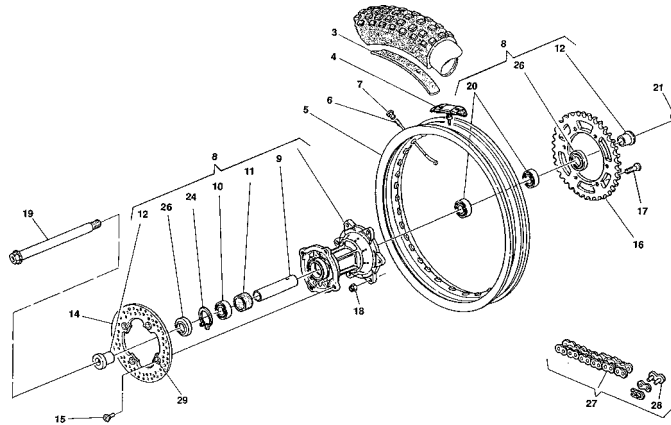

Pagina - Page - Page - Seite - Paja

82

Tavola - Drawing - Table - Bild - Tabla

24

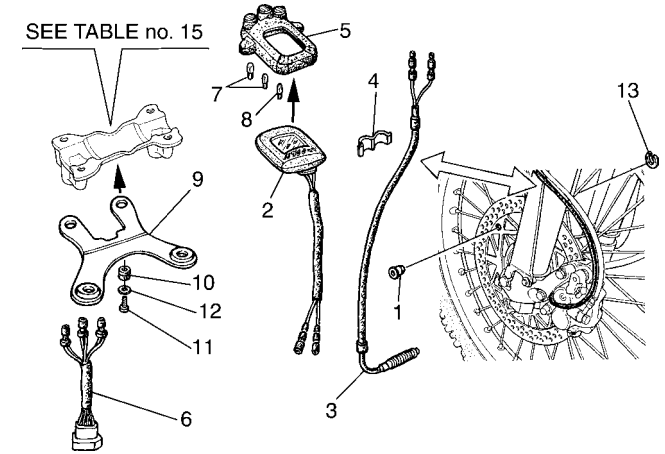

Pagina - Page - Page - Seite - Paja

86

Tavola - Drawing - Table - Bild - Tabla

25

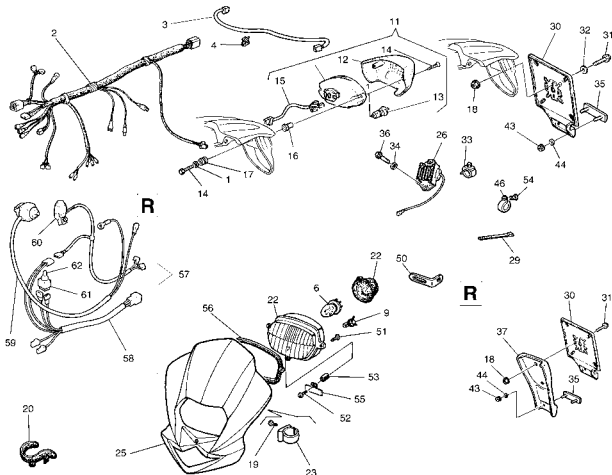

Pagina - Page - Page - Seite - Paja

88

Tavola - Drawing - Table - Bild - Tabla

26

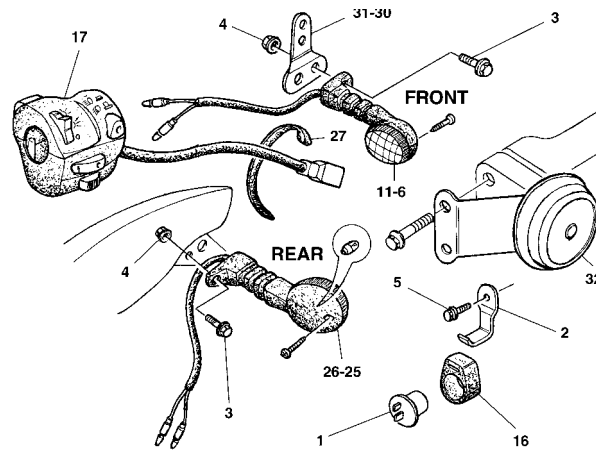

Pagina - Page - Page - Seite - Paja

92

Tavola - Drawing - Table - Bild - Tabla

27

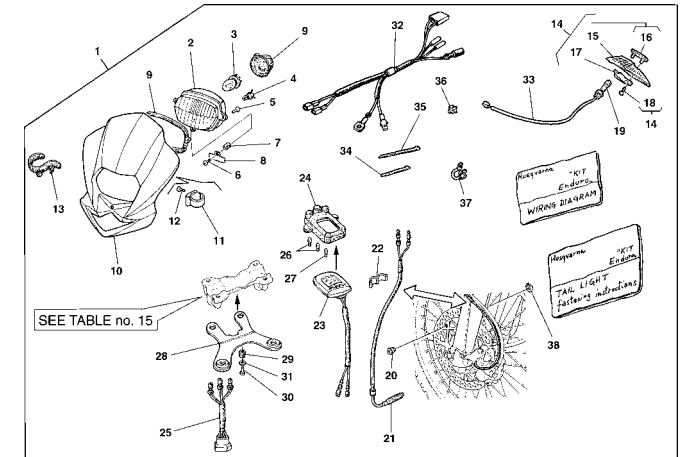

Pagina - Page - Page - Seite - Paja

94

Tavola - Drawing - Table - Bild - Tabla

28



Pagina - Page - Page - Seite - Paja

98

Tavola - Drawing - Table - Bild - Tabla

29



Pagina - Page - Page - Seite - Paja

100

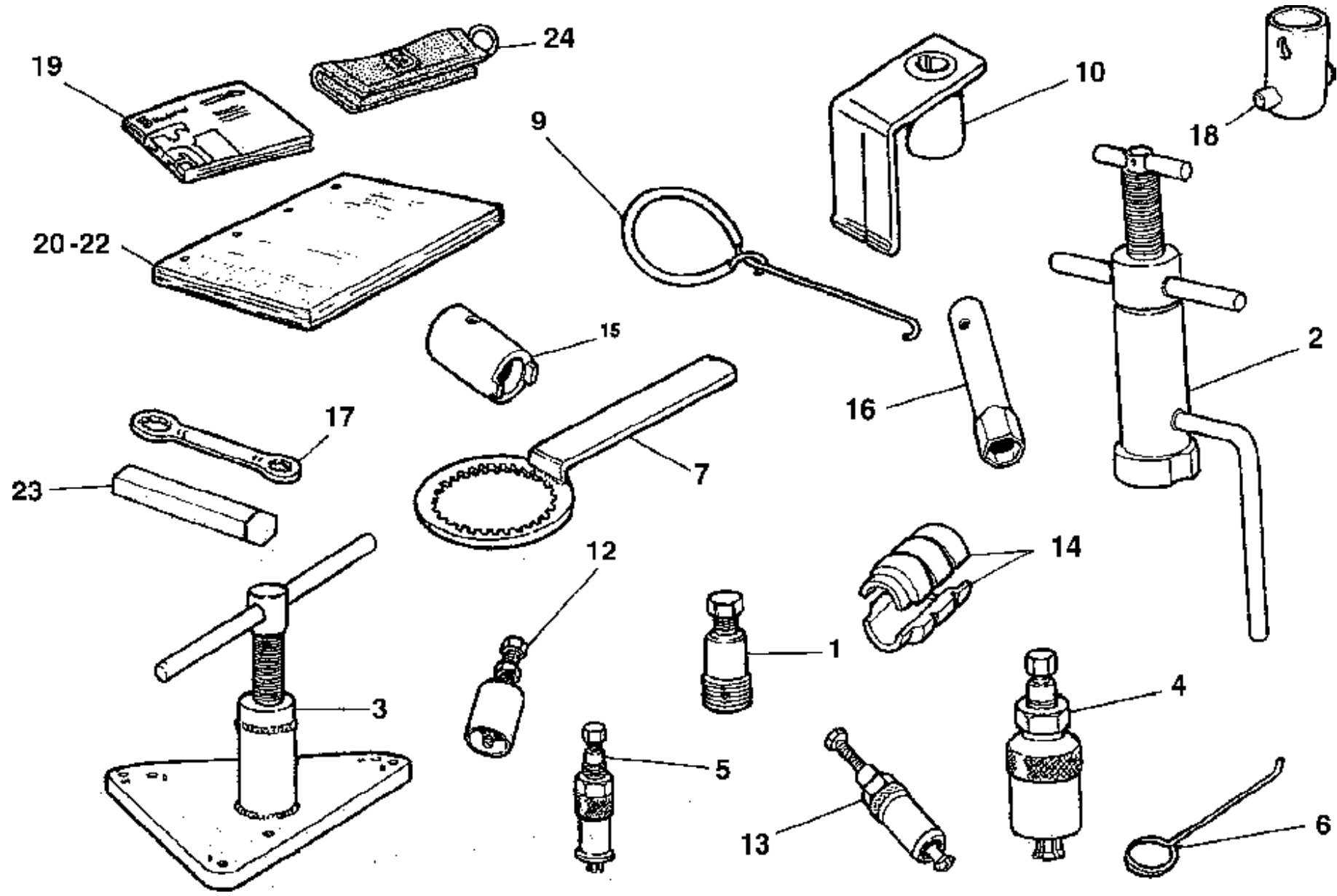

Note Notes Notas	Pos. No. Index Pos.	N. Cod. Code No. Nr. Code Code Nr N. Cod.	Q.tà Q.ty Q.te M.ge C.ad	DENOMINAZIONE	NAME	DESIGNATION	BESHREIBUNG	DENOMINACION	Validità Validity Validité Gültig Validez
W	1	8000 60516	1	Estrattore rotore accensione	Rotor puller	Extracteur rotor allumage	Auszieher Rotor zundung	Extractor rotor encendido	
C	1	8000 46613	1	Estrattore rotore accensione	Rotor puller	Extracteur rotor allumage	Auszieher Rotor zundung	Extractor rotor encendido	
	2	8000 58256	1	Attrezzo mont. alb. motore nel carter sx.	Installing tool. crankshaft left	Outil pour montage vilebr. dans le demicarter G.	Werkzeug für Mont. Motorwelle im linken Kurbelgehäuse	Herramienta mont. eje motor en el carter izq.	
	3	8000 58258	1	Attrezzo separaz. semicarter	Crankcase splitting tool	Outil dem. demic. vilebreq.	Werkzeug um Halbgehäuse	Herramienta semi-carter	
	4	8000 43720	1	Estrattore cuscinetto albero comando cambio	Bearing extractor	Extracteur pour roulement	Auszieher für rollenlayers	Extractor cojinete	
	5	8000 43824	1	Estratt. cuscin. a rullini rinvio com. valvola e pompa acqua	Extracteur for roller bearing valve drive gear & water pump	Ext. roulement à aiguilles renvoi com.soup.pompe eau	Abzie.für Nadellager Vorgelege Ventil wasserpumpelagerung	Extractor cojinete de rulos mando valvola y bomba agua	
	7	8000 39524	1	Chiave blocc. mozzo frizione	Clutch hub retaining wrench	Cléf arret moyeau embrayage	Halierungsschlüssel der	Llave bloquear cubo fricción	
	9	1519 84701	1	Gancio per molle	Hook	Crochet	Haken	Gancho	
W	10	8000 75578	1	Attrezzo controllo fase acc.	Ignition control tool	Outil Pour surveillance allumage	Werkzeug kontr. der zundungl	Herramientas control fase encendido	
C	10	8000 75579	1	Attrezzo controllo fase acc.	Ignition control tool	Outil Pour surveillance allumage	Werkzeug kontr. der zundungl	Herramientas control fase encendido	
	12	8000 90659	1	Attrezzo valvola Booster	Booster installing tool	Outil montage Booster	Werkz. mont. Booster	Herram. mont. Booster	
	13	8000 43823	1	Estrattore cuscinetto	Needle bearing extractor	Extracteur pour roulement	Auszieher für Nadelkäfig	Extractor cojinete	
	14	8000 91288	1	Introduttore MIM	Jaw	Machoire	Zusatzbacke	Tenaza	
	15	8000 91289	1	Attrezzo blocca cartuccia	Pumping retainer	Arret pompage	Klammer pumpen	Broche bombeadora	
D	16	8000 70836	1	Chiave candela	Spark plug wrench	Cléf bougie	Zündkerzeschlüssel	Llave bujia	
D	17	8000 66802	1	Chiave poligonale	Box wrench	Clé polygonale	Sechskantschlüssel	Llave poligonal	
D	18	8000 96997	1	Chiave perno ruota anteriore	Front wheel axle wrench	Cléf pivot roue avant	Vorterrad bolzen schlüssel	Llave perno rueda delantera	
D	19	8000 A2953	1	Libr. uso e manutenzione	Owner's manual	Emploi d'entretien	Betriebsanleitung	Manuàl uso y mantenimiento	
R	20	8000 A2954	1	Manuale di officina	Workshop manual	Manuel d'atelier	Werkstatthandbuch	Manual de Oficina	
R	22	8000 A2955	1	Catalogo PARTI DI RICAMBIO	SPARE PARTS catalog	Catalogue PIECES DE RECHANGE	ERSATZTEILKATALOG	Catalogo "PIEZAS DE REPUESTO"	
D	23	8000 56920	1	Chiave esagonale per vite perno ruota anteriore	Front wheel axle screw Allen wrench	Clef à douille pour vis de pivot roue avant	Sechs Kantschlüssel für Vorderradbolzen schraube	Llave hexagonal por tornillo perno rueda delantera	
DW	24	8000 97615	1	Porta chiavi	Key-ring	Porte-clefs	Schlüsselring	Llavero	

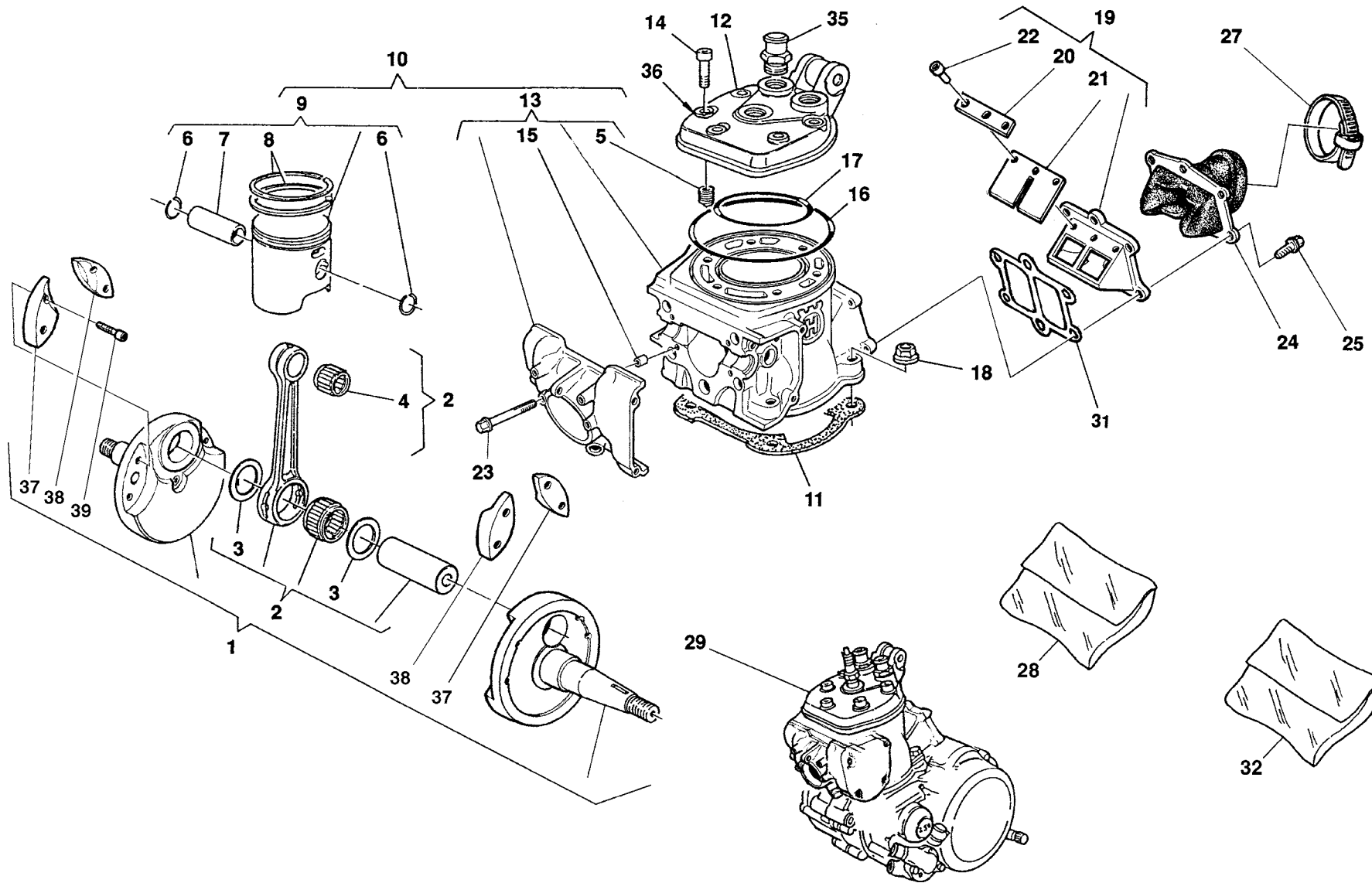

Note Notes Notas	Pos. No. N. Index Pos.	N. Cod. Code No. Nr. Code Code Nr N. Cod.	Q.tà Q.ty Q.te M.ge C.ad	DENOMINAZIONE	NAME	DESIGNATION	BESHREIBUNG	DENOMINACION	Validità Validity Validité Gültig Validez
	1	8000 89024	1	Albero motore completo	Crankshaft assy	Vilebrequin compl.	Kurbewelle kpl.	Cigüeñal compl.	
	2	8A00 50632	1	Biella completa	Connecting rod compl.	Bielle compl.	Pleuelstange kpl.	Biela motor completa	
	3	8000 50629	2	Rosetta di rasamento	Washer	Rondelle	Scheibe	Arandela	
H	4	8000 17826	1	Cuscinetto a rullini (Ø18xØ22x22mm)	Needle bearing (Ø18xØ22x22mm)	Roulement à aiguilles (Ø18xØ22x22mm)	Nadelkäfig (Ø18xØ22x22mm)	Cojinete de rodillos (Ø18xØ22x22mm)	
	5	8A00 30729	6	Helicoil	Inserted thread	Filetage appliq	Gewindeinsatz	Fileteado aplicado	
	6	8000 87765	2	Anello di fermo	Stop ring	Bague d'arrêt	Haltering	Anillo de retención	
	7	8000 86817	1	Spinotto	Gudgeon	Axe	Bolzen	Perno	
	8	8000 86819	2	Segmento	Circlip	Segment	Kolbenring	Segmento	
	9		1	Pistone completo	Compl. piston	Piston complet	Kolbe, kpl.	Pistón completo	
	9	8000 86806/1	1	A-B (Ø66,335÷66,345 mm)	A-B (Ø66,335÷66,345 mm)	A-B (Ø66,335÷66,345 mm)	A-B (Ø66,335÷66,345 mm)	A-B (Ø66,335÷66,345 mm)	
	9	8000 86806/2	1	C-D (Ø66,345÷66,355 mm)	C-D (Ø66,345÷66,355 mm)	C-D (Ø66,345÷66,355 mm)	C-D (Ø66,345÷66,355 mm)	C-D (Ø66,345÷66,355 mm)	
	9	8000 86806/3	1	E-F (Ø66,355÷66,365 mm)	E-F (Ø66,355÷66,365 mm)	E-F (Ø66,355÷66,365 mm)	E-F (Ø66,355÷66,365 mm)	E-F (Ø66,355÷66,365 mm)	
E	10	8000 97233	1	Cilindro completo	Cylinder assy	Cylindre compl.	Zylinder kpl.	Cilindro compl.	
	10	8000 99895	1	Cilindro completo	Cylinder assy	Cylindre compl.	Zylinder kpl.	Cilindro compl.	
	11	8000 86902	1	Guarnizione (0,3 mm)	Gasket (0,3 mm)	Garniture (0,3 mm)	Dichtung (0,3 mm)	Junta (0,3 mm)	
	11	8A00 86902	1	Guarnizione (0,4 mm)	Gasket (0,4 mm)	Garniture (0,4 mm)	Dichtung (0,4 mm)	Junta (0,4 mm)	
	11	8B00 86902	1	Guarnizione (0,5 mm)	Gasket (0,5 mm)	Garniture (0,5 mm)	Dichtung (0,5 mm)	Junta (0,5 mm)	
	11	8C00 86902	1	Guarnizione (0,8 mm)	Gasket (0,8 mm)	Garniture (0,8 mm)	Dichtung (0,8 mm)	Junta (0,8 mm)	
	12	8000 86823	1	Testa cilindro	Cylinder head	Culasse	Zylinderkopf	Cabeza cilindro	
E	13	8000 97234	1	Ass. cilindro	Cylinder assy	Groupe culasse	Zylindergruppe	Grupo cilindro	
	13	8000 99896	1	Ass. cilindro	Cylinder assy	Groupe culasse	Zylindergruppe	Grupo cilindro	
	14	8K00 69056	6	Vite M8x35mm	Screw M8x35mm	Vis M8x35mm	Schraube M8x35mm	Tornillo M8x35mm	
	15	1617 95501	2	Bussola	Bush	Douille	Buchse	Manguito	
	16	8A00 63593	1	Anello OR	O-Ring	Bague OR	O-Ring	Anillo OR	
	17	8A00 44117	1	Anello OR	O-Ring	Bague OR	O-Ring	Anillo OR	
	18	8000 38624	4	Dado	Nut	Ecrou	Mutter	Tuerca	
W	19	8000 86825	1	Valvola aspirazione completa	Inlet valve assy	Soupape d'aspiration compl.	Einlassventil kpl.	Válvula de aspiración compl.	
CU	19	8000 A0803	1	Valvola aspirazione completa	Inlet valve assy	Soupape d'aspiration compl.	Einlassventil kpl.	Válvula de aspiración compl.	
	20	8000 86827	2	Piastrina di fermo	Stop plate	Plaque d'arrêt	Stopplatte	Placa de retención	
	21	8000 86828	2	Lamella	Plate	Lamelle	Plättchen	Laminilla	
	22	8000 61102	6	Vite	Screw	Vis	Schraube	Tornillo	
	23	8E00 67545	4	Vite	Screw	Vis	Schraube	Tornillo	

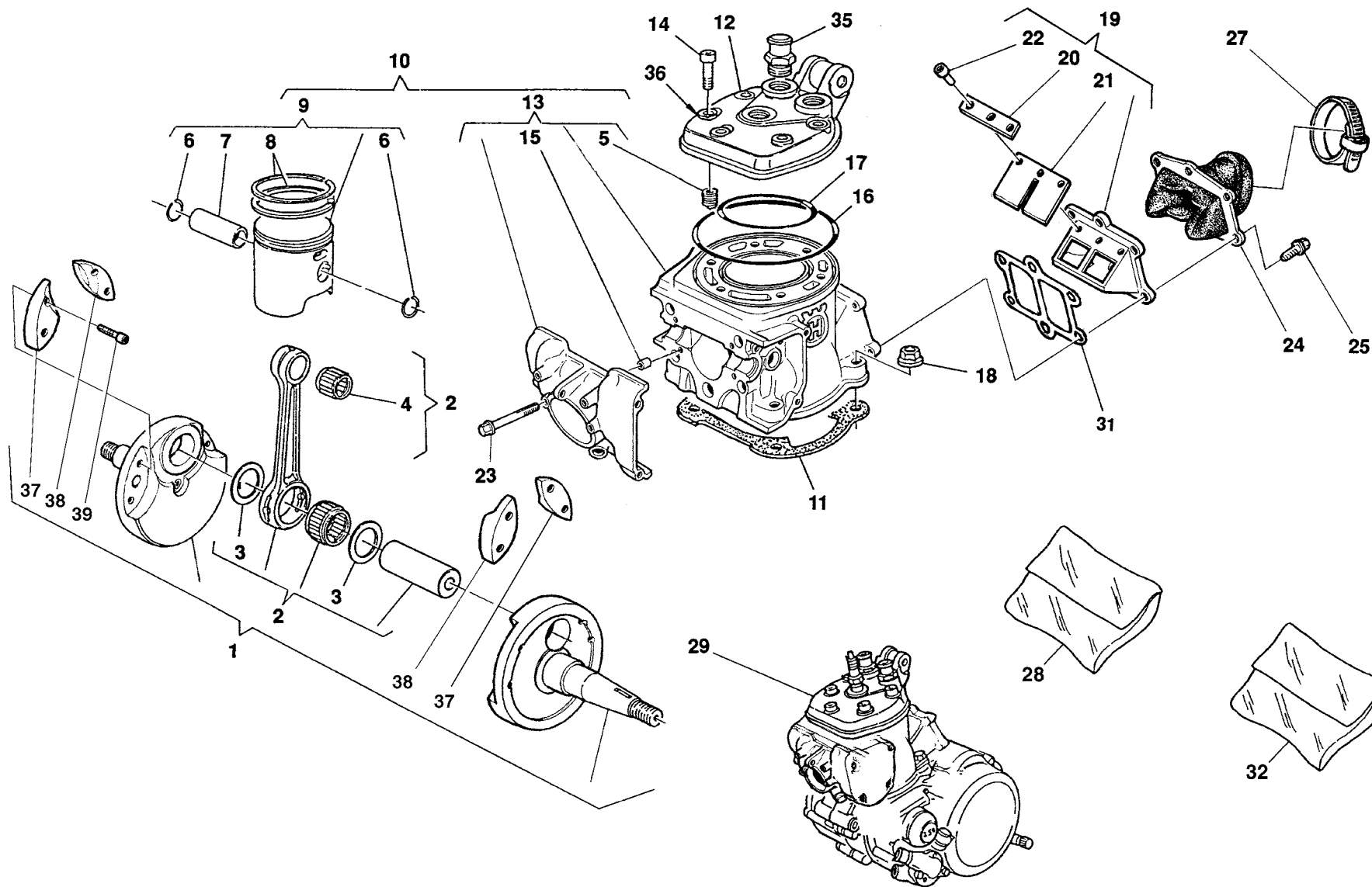

Note Notes Mark Notas	Pos. No. N. Index Pos.	N. Cod. Code No. Nr. Code Code Nr N. Cod.	Q.tà Q.ty Q.te M.ge C.ad	DENOMINAZIONE	NAME	DESIGNATION	BESHREIBUNG	DENOMINACION	Validità Validity Validité Gültig Validez
W	24	8000 86851	1	Raccordo di aspirazione	Union	Raccord	Anschluss	Empalme	
CU	24	8000 A0802	1	Raccordo di aspirazione	Union	Raccord	Anschluss	Empalme	
	25	8000 62729	6	Vite	Screw	Vis	Schraube	Tornillo	
	27	8000 27521	1	Fascetta	Clamp	Collier	Schelle	Banda	
R	28	8000 94853	1	Gruppo guarnizioni motore	Engine gasket set	Groupe garnitures moteur	Dichtunggruppe Motor	Grupo juntas	
W	29	8000 99891	1	Motore completo	Crankshaft assy	Vilebrequin compl.	Kurbewelle kpl.	Cigüeñal compl.	
U	29	8000 99901	1	Motore completo	Crankshaft assy	Vilebrequin compl.	Kurbewelle kpl.	Cigüeñal compl.	
C	29	8000 A1856	1	Motore completo	Crankshaft assy	Vilebrequin compl.	Kurbewelle kpl.	Cigüeñal compl.	
	31	8000 89954	1	Guarnizione	Gasket	Garniture	Dichtung	Junta	
	32	8000 99893	1	Gruppo anelli di tenuta motore	Engine seal ring set	Groupe bague moteur	Dichtungringgruppe Motor	Grupo anillos	
	35	8000 63885	2	Raccordo	Union	Raccord	Anschluss	Empalme	
	36	8B00 64988	6	Rosetta piana in rame	Washer	Rondelle	Scheibe	Arandela	
	37	8000 89025	2	Inserto sinistro	L.H. insert	Insert gauche	Link Platte	Inserto izquierdo	
	38	8000 89026	2	Inserto destro	R.H. insert	Insert droite	Recht Platte	Inserto .0derecho	
	39	60N1 02506	4	Vite	crew	Vis	Schraube	Tornillo	
H				Accoppiamento piede biella	Con.road small end coupl.	Couplage du pied de bielle	Verbin. pluelstangenkopfes	Acoplamiento pie de biela	

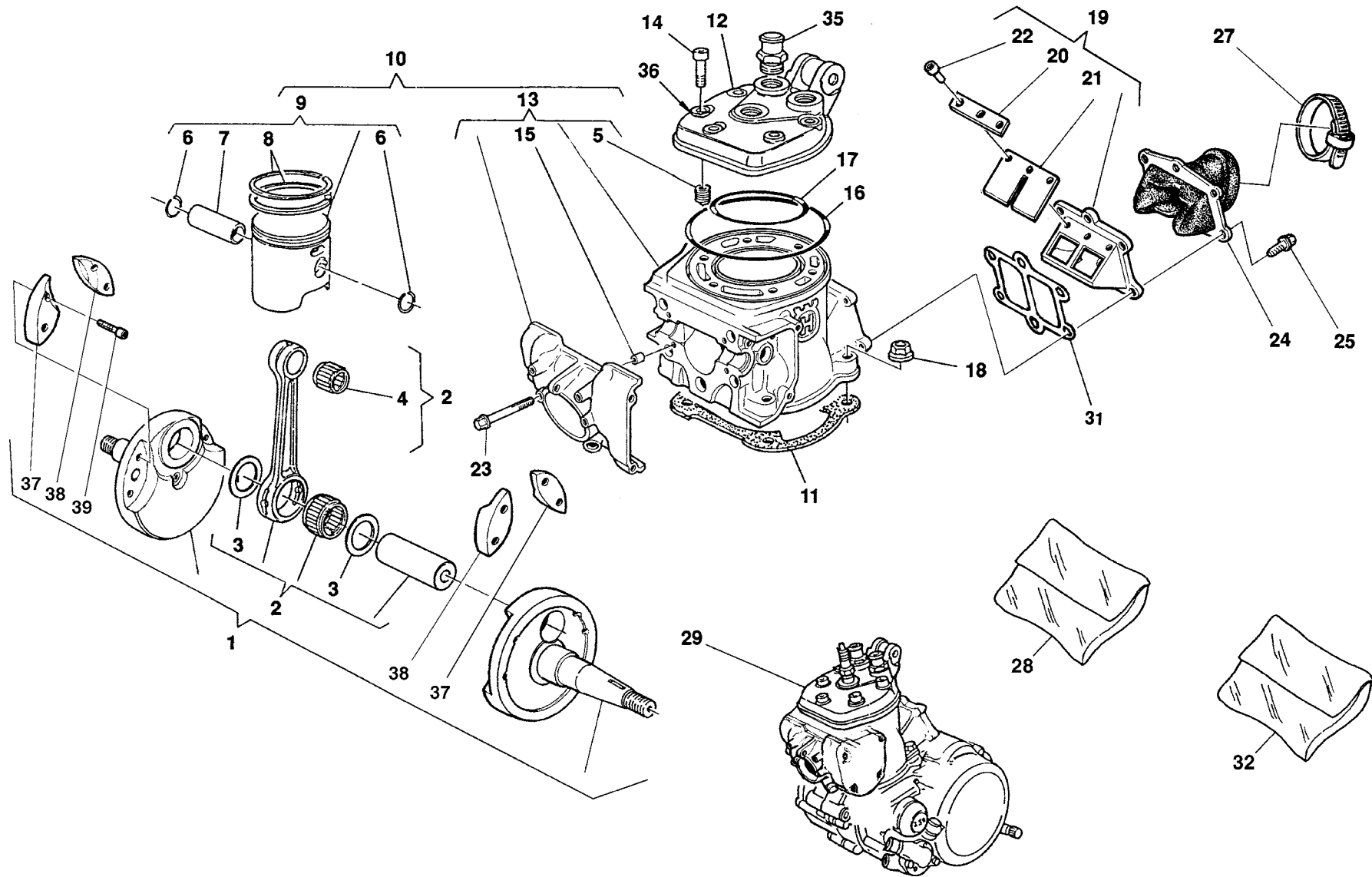

La sottoriportata tabella elenca i possibili accoppiamenti che consentono di ottenere il corretto gioco radiale di 0,002±0,010 mm

The table hereunder shows the possible coupling which allow to obtain a radial clearance of 0.002±0.010 mm

Le tableau ci-dessous indique tous les couplages possibles permettant d'obtenir le jeu radial exact de 0,002±0,010 mm

Die folgende Tabelle gibt die möglichen Verbindungen an für das genaue Radialspiel von 0,002±0,010 mm

La tabla que se da a continuación lista los acoplamientos posibles que permiten obtener el juego radial correcto de 0,002±0,010 mm

C: colore di selezione biella

C: rod selection colour

C: couleur de sélection bielle

C: Wahlfarbe der Pleuelstange

C: color de selección biela

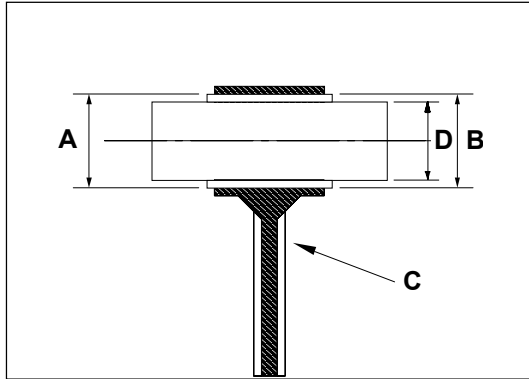

Colore di selezione foro «A» piede di biella (mm) Hole selection colour «A» connecting rod small end (mm) Couleur de sélection trou «A» pied de bielle (mm) Wahlfarbe der Bohrung «A» Pleuelstangenkopf (mm) Color de selección «A» pie de biela (mm)	Selezione gabbia a rullini «B» Cage selection «B» Sélection cage à rouleaux «B» Wahlnadelkäfig «B» Selección jaula de agujas «B»	Colore di selezione diametro «D» spinotto (mm) Diameter selection colour «D» Gudgeon (mm) Couleur de sélection diamètre «D» axe (mm) Wahlfarbe der Durchmesser «D» Bolzen (mm) Color de selección diámetro «D» perno (mm)
Bianco - White - Blanc - Weiss - Blanco 21,998 ÷ 22,000	- 2 ÷ - 4	Nero - Black - Noir - Schwarz - Negro 18,000 ÷ 18,998
Bianco - White - Blanc - Weiss - Blanco 21,998 ÷ 22,000	- 1 ÷ - 3	Bianco - White - Blanc - Weiss - Blanco 18,998 ÷ 18,996
Nero - Black - Noir - Schwarz - Negro 22,000 ÷ 22,002	0 ÷ - 2	Bianco - White - Blanc - Weiss - Blanco 18,998 ÷ 18,996
Nero - Black - Noir - Schwarz - Negro 22,000 ÷ 22,002	- 1 ÷ - 3	Nero - Black - Noir - Schwarz - Negro 18,000 ÷ 18,998
Rosso - Red - Rouge - Rot - Rojo 22,002 ÷ 22,004	0 ÷ - 2	Nero - Black - Noir - Schwarz - Negro 18,000 ÷ 18,998
Verde - Green - Vert - Grün - Verde 21,996 ÷ 21,998	- 3 ÷ - 5	Nero - Black - Noir - Schwarz - Negro 18,000 ÷ 18,998
Giallo - Yellow - Jaune - Gelb - Amarillo 21,994 ÷ 21,996	- 3 ÷ - 5	Bianco - White - Blanc - Weiss - Blanco 18,998 ÷ 18,996

Qualora, in sede di revisione del motore, si dovesse riscontrare un gioco radiale superiore al limite ammesso di 0,015 mm e non fosse più visibile il contrassegno del colore sullo stelo della biella, rilevare il diametro «A» del piede di biella e, in base a questo, montare la gabbietta appropriata.

When overhauling, should a radial clearance greater than the consented limit of 0.015 mm be noticed and the colour mark under the connecting rod small end is no more visible, collect the connecting rod small end «A» diameter and assemble the right cage according to it.

Si en révisonnant le moteur on trouve un jeu radial supérieur à la limite admise de 0,015 mm et le marque de la couleur n'est plus visible sur la tige de bielle, enregistrer le diamètre «A» du pied de bielle et assembler la cage exacte selon ce diamètre.

Falls bei Motorprüfung das Radialspiel über das zugelassene Mass von 0,015 mm sein sollte und das Farbkennzeichen an der Pleuelstange nicht mehr sichtbar ist, wird der «A»-Durchmesser des Pleuelstangenkopfes gemessen und aufgrund dessen der geeignete Käfig montiert.

En el caso que, cuando inspeccione el motor, encuentre un juego radial superior al límite admitido de 0,015 mm y no resultara más visible la señalización del color en el vástago de la biela, registre el diámetro «A» del piede biela y, sobre la base de este dato, monte la jaula adecuada.

NOTA: Nel richiedere la gabbia a rullini, specificare la selezione.

NOTE: When requesting the cage, specify the selection.

NOTA: En demandant la cage à rouleaux, spécifier la sélection.

BEMERKUNG: Bei Anfrage den genauen Wahlnadelkäfig angeben.

NOTA: cuando pida la jaula de agujas, especifique la selección.

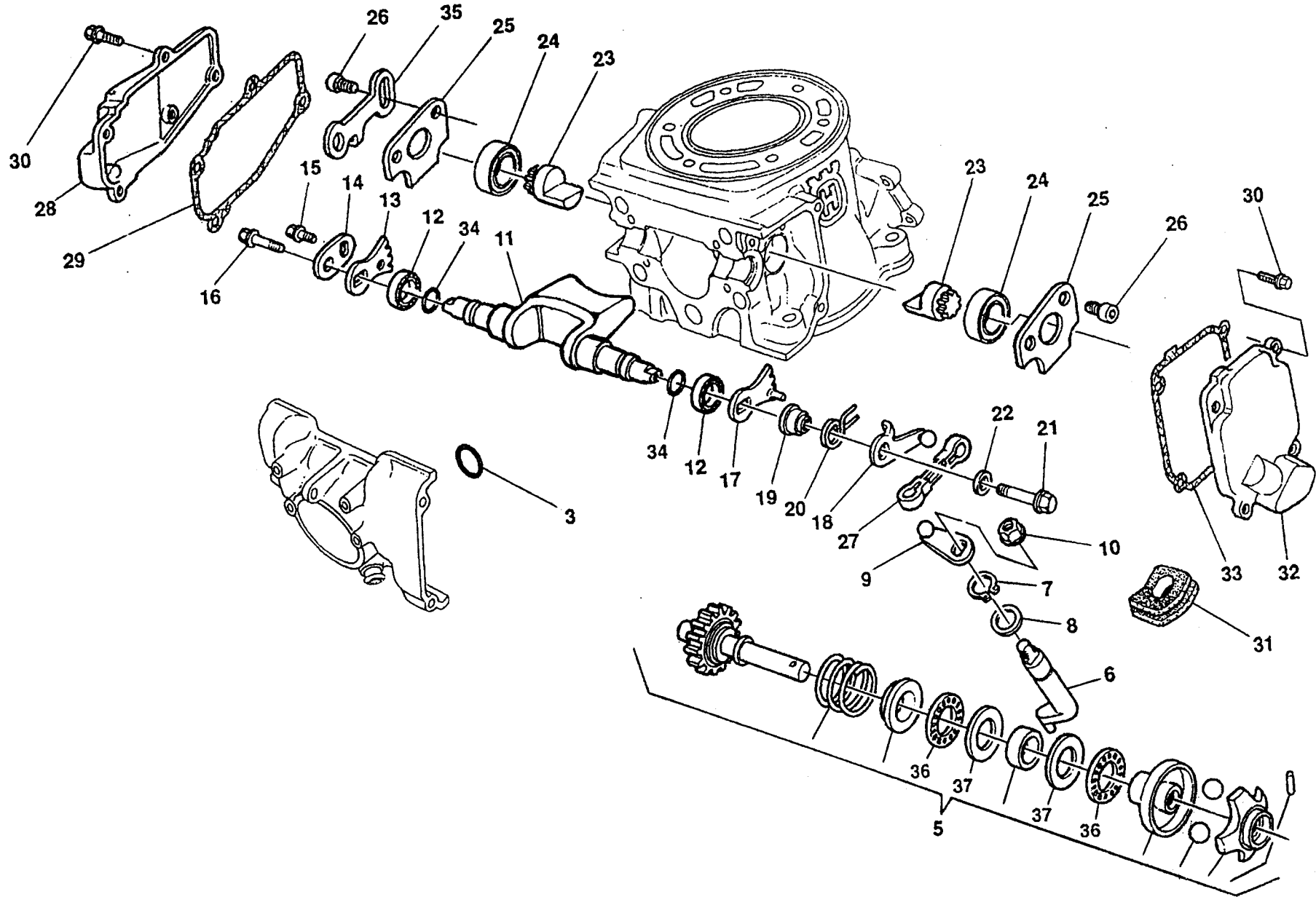

Note Notes Notas	Pos. No. N. Index Pos.	N. Cod. Code No. Nr. Code Code Nr N. Cod.	Q.tà Q.ty Q.te M.ge C.ad	DENOMINAZIONE	NAME	DESIGNATION	BESHREIBUNG	DENOMINACION	Validità Validity Validité Gültig Validez
	3	8B00 42700	1	Anello OR	O-Ring	Bague OR	O-Ring	Anillo OR	
	5	8000 86840	1	Regolatore comando valvola di scarico	Valve drive regulator	Registre com. soupape	Regler für Abzapventil.	Regul. mando válvula	
	6	8000 86843	1	Alberino rinvio	Counter shaft	Arbre de renvoi	Vorgelegewelle	Eje de reencío	
	7	8000 21375	1	Anello SEEGER	SEEGER ring	Anneau SEEGER	SEEGER Ring	Anillo SEEGER	
	8	8000 56377	1	Rosetta	Washer	Rondelle	Scheibe	Arandela	
	9	8000 54899	1	Leva	Lever	Levier	Hebel	Palanca	
	10	8000 42278	1	Dado	Nut	Ecrou	Mutter	Tuerca	
	11	8000 97252	1	Valvola di scarico	Exhaust valve	Soupape d'échappement	Auslass-Ventil	Válvula de escape	
	12	8000 89957	2	Bussola	Bushing	Douille	Buchse	Manguito	
	13	8A00 86845	1	Ingranaggio Dx	R.H. gear	Engrenage D.	Zahnrad Rechte	Engranaje der.	
	14	8000 86847	1	Piastrina	Plate	Plaque	Platte	Placa	
	15	8F00 67997	1	Vite	Screw	Vis	Schraube	Tornillo	
	16	8000 62728	1	Vite	Screw	Vis	Schraube	Tornillo	
	17	8000 86846	1	Ingranaggio Sx	L.H. gear	Engrenage G.	Zahnrad Linke	Engranaje iz.	
	18	8000 82943	1	Leva	Lever	Levier	Hebel	Palanca	
	19	8000 86849	1	Mozzo	Hub	Moyeau	Radnabe	Cubo	
	20	8000 86850	1	Molla	Spring	Ressort	Feder	Resorte	
	21	8000 62730	1	Vite	Screw	Vis	Schraube	Tornillo	
	22	8000 02709	1	Rosetta	Washer	Rondelle	Scheibe	Arandela	
	23	8000 86844	2	Valvola BOOSTER	BOOSTER valve	Soupape BOOSTER	Auslass BOOSTER	Válvula BOOSTER	
	24	8000 92225	2	Bussola	Bushing	Douille	Buchse	Manguito	
	25	8000 86848	2	Piastrina	Plate	Plaque	Platte	Placa	
	26	8000 67997	4	Vite	Screw	Vis	Schraube	Tornillo	
	27	8000 69750	1	Astina	Control rod	Coulisseau	Steuerstange	Varilla	
	28	8000 86864	1	Coperchio Dx	R.H. cover	Couvercle D.	Deckel Rechte	Tapa der.	
	29	8000 86865	1	Guarnizione	Gasket	Garniture	Dichtung	Junta	
	30	8000 62727	9	Vite	Screw	Vis	Schraube	Tornillo	
	31	8000 86866	1	Passacavo	Fairlead	Passecâble	Kabelführung	Prensacable	
	32	8000 86867	1	Coperchio Sx	L.H. cover	Couvercle G.	Deckel Linke	Tapa iz.	
	33	8000 86868	1	Guarnizione	Gasket	Garniture	Dichtung	Junta	
	34	8A00 22551	2	Anello OR	O-Ring	Bague OR	O-Ring	Anillo OR	
	35	8000 91719	1	Piastrina	Plate	Plaque	Platte	Placa	

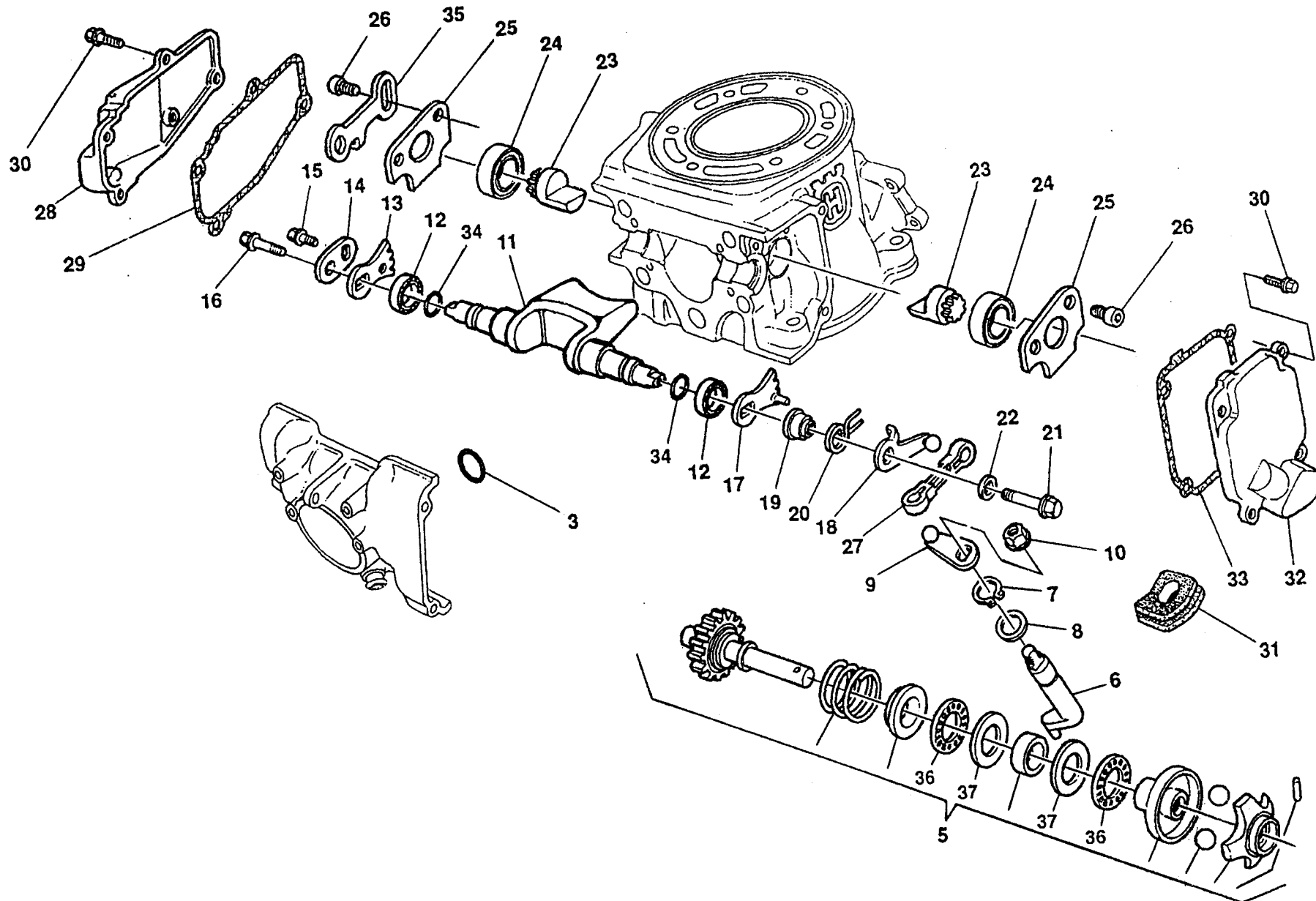



CR-WR 250 /2004

TAVOLA
DRAWING
TABLE
BILD
TABLA

3

H.T.S.

Note Notes Marke Notas	Pos. No. N. Index Pos.	N. Cod. Code No. Nr. Code Code Nr N. Cod.	Q.tà Q.ty Q.te M.ge C.ad	DENOMINAZIONE	NAME	DESIGNATION	BESHREIBUNG	DENOMINACION	Validità Validity Validité Gültig Validez
	36	8000 35780	2	Cuscinetto assiale	Bearing	Roulement	Lager	Cojinete	
	37	8000 35781	2	Ralla	Washer	Rondelle	Scheibe	Arandela	

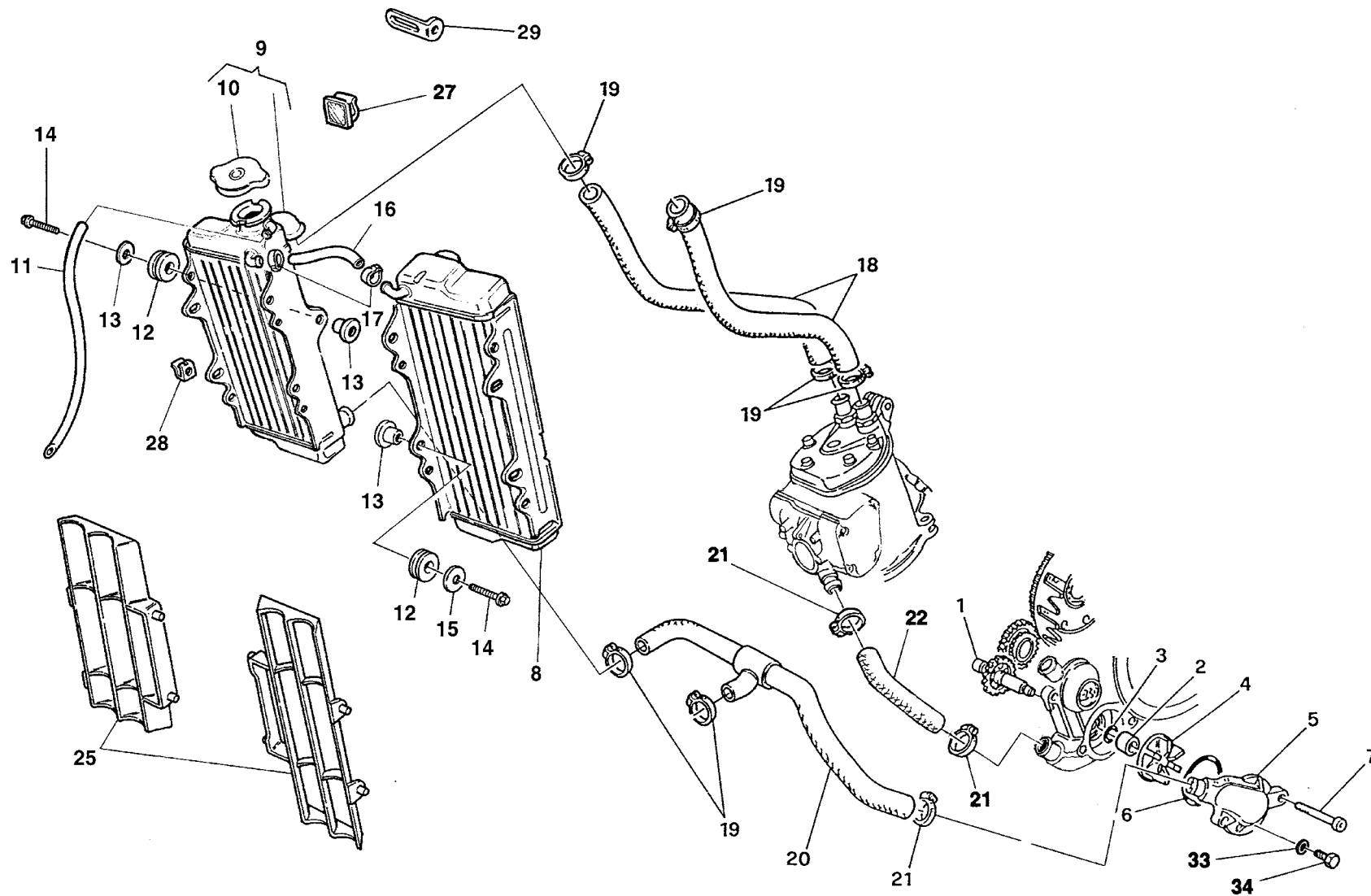

Note Notes Notas	Pos. No. Index Pos.	N. Cod. Code No. Nr. Code Code Nr N. Cod.	Q.tà Q.ty Q.te M.ge C.ad	DENOMINAZIONE	NAME	DESIGNATION	BESHREIBUNG	DENOMINACION	Validità Validity Validité Gültig Validez
	1	8000 59843	1	Alb. rinvio com. pompa	Counter shaft	Arbre de renvoi	Vorgelegewelle	Eje de reencío	
	2	8000 59844	1	Distanziale	Spacer	Entretoise	Distanzstück	Separador	
	3	8000 34083	1	Anello OR	O-Ring	Bague OR	O-Ring	Anillo OR	
	4	8000 59845	1	Girante	Rotor	Couronne	Laufgrad	Rotor	
	5	80B0 82940	1	Coperchio pompa	Pump cover	Couvercle pompe	Pumpendeckel	Tapa bomba	
	6	8000 19965	1	Anello OR	O-Ring	Bague OR	O-Ring	Anillo OR	
	7	8B00 67545	2	Vite	Screw	Vis	Schraube	Tornillo	
	8	8000 92215	1	Radiatore sinistro	Left radiator	Radiateur gauche	Linker Kühler	Radiador izquierdo	
	9	8000 92216	1	Radiatore destro	Right radiator	Radiateur droit	Rechter Kühler .	Radiador derecho	
	10	8000 79077	1	Tappo radiatore	Plug	Bouchon	Verschluss	Tapón	
	11	8B00 43715	1	Tubo sfiato (L=660 mm)	Pipe (L=660 mm)	Tuyau (L=660 mm)	Rohr (L=660 mm)	Tubo (L=660 mm)	
	12	8000 59803	6	Gommino	Rubber pad	Pièce caoutchouc	Gummistück	Junta de goma	
	13	8D00 59802	6	Bussola	Bushing	Douille	Buchse	Manguito	
	14	8000 62729	6	Vite	Screw	Vis	Schraube	Tornillo	
	15	8000 59801	6	Rosetta	Washer	Rondelle	Scheibe	Arandela	
	16	8B00 99475	1	Fascetta	Clamp	Collier	Schelle	Banda	
	17	8000 56462	2	Fascetta	Clamp	Collier	Schelle	Banda	
	18	8000 94117	2	Tubo testa-radiatori	Pipe	Tuyau	Rohr	Tubo	
	19	8A00 99475	4	Fascetta	Clamp	Collier	Schelle	Banda	
	20	8A00 73340	1	Tubo radiatori- pompa	Pipe	Tuyau	Rohr	Tubo	
	21	8B00 99475	3	Fascetta	Clamp	Collier	Schelle	Banda	
	22	8000 86887	1	Condotto	Pipe	Tuyau	Rohr	Tubo	
	25	8000 A0872	2	Griglia	Grid	Grille	Rost	Parrilla	
U	27	8000 57205	1	Gancio ritegno cavi	Hook	Crochet	Haken	Gancho	
	28	8000 60873	4	Dado a graffetta	Nut	Ecrou	Mutter	Tuerca	
	29	8AA0 55705	1	Piastrina	Plate	Plateau	Teller	Placa	
	33	8000 64988	1	Rosetta	Washer	Rondelle	Scheibe	Arandela	
	34	8000 62725	1	Vite	Screw	Vis	Schraube	Tornillo	

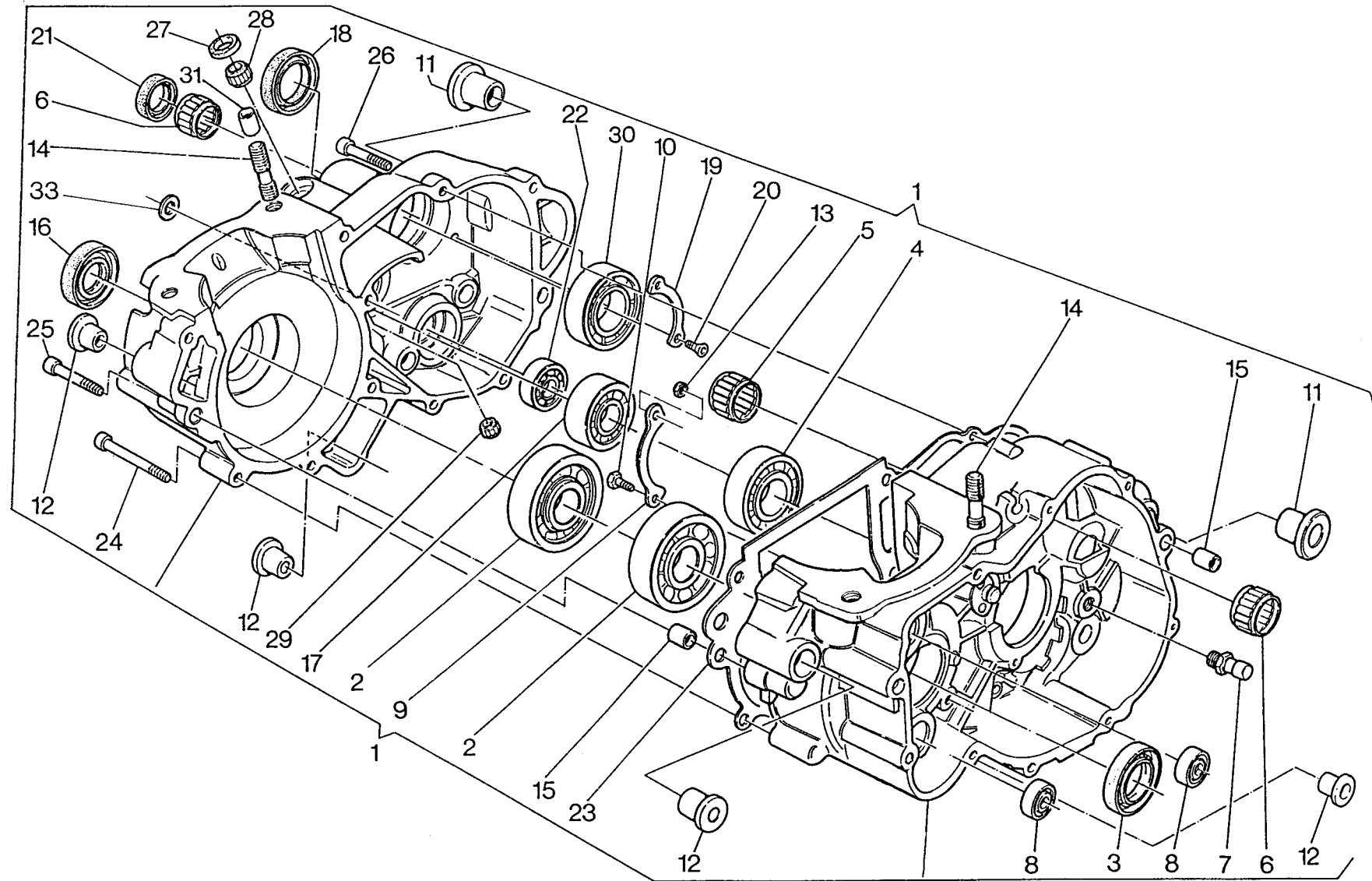

Note Notes Notas	Pos. No. N. Index Pos.	N. Cod. Code No. Nr. Code Code Nr N. Cod.	Q.tà Q.ty Q.te M.ge C.ad	DENOMINAZIONE	NAME	DESIGNATION	BESHREIBUNG	DENOMINACION	Validità Validity Validité Gültig Validez
	1	8000 86872	1	Carters motore comp.	Crankcase assy	Carter compl.	Kurberlgehaue kpl.	Carter motor compl.	
	2	8000 42155	2	Cuscinetto albero motore ($\varnothing 25 \times \varnothing 62 \times 17$ mm)	Ball bearing ($\varnothing 25 \times \varnothing 62 \times 17$ mm)	Roulement à billes ($\varnothing 25 \times \varnothing 62 \times 17$ mm)	Kugellager ($\varnothing 25 \times \varnothing 62 \times 17$ mm)	Cojinete de bolas ($\varnothing 25 \times \varnothing 62 \times 17$ mm)	
	3	8000 59977	1	Anello di tenuta ($\varnothing 32 \times \varnothing 40 \times 5$ mm)	Seal ring ($\varnothing 32 \times \varnothing 40 \times 5$ mm)	Bague d'étanchéité ($\varnothing 32 \times \varnothing 40 \times 5$ mm)	Dichtungsring ($\varnothing 32 \times \varnothing 40 \times 5$ mm)	Anillo de retención ($\varnothing 32 \times \varnothing 40 \times 5$ mm)	
	4	8000 24952	1	Cusc. a sfere ($\varnothing 25 \times \varnothing 52 \times 15$ mm)	Ball bearing ($\varnothing 25 \times \varnothing 52 \times 15$ mm)	Roulement à billes ($\varnothing 25 \times \varnothing 52 \times 15$ mm)	Kugellager ($\varnothing 25 \times \varnothing 52 \times 15$ mm)	Cojinete de bolas ($\varnothing 25 \times \varnothing 52 \times 15$ mm)	
	5	8000 36440	1	Cusc. a rullini ($\varnothing 20 \times \varnothing 28 \times 13$ mm)	Needle bearing ($\varnothing 20 \times \varnothing 28 \times 13$ mm)	Roulement à aiguilles ($\varnothing 20 \times \varnothing 28 \times 13$ mm)	Nadelkäfig ($\varnothing 20 \times \varnothing 28 \times 13$ mm)	Cojinete de rodillos ($\varnothing 20 \times \varnothing 28 \times 13$ mm)	
	6	8000 48212	2	Cusc. a rullini ($\varnothing 20 \times \varnothing 26 \times 12$ mm)	Needle bearing ($\varnothing 20 \times \varnothing 26 \times 12$ mm)	Roulement à aiguilles ($\varnothing 20 \times \varnothing 26 \times 12$ mm)	Nadelkäfig ($\varnothing 20 \times \varnothing 26 \times 12$ mm)	Cojinete de rodillos ($\varnothing 20 \times \varnothing 26 \times 12$ mm)	
	7	8000 46860	1	Perno fermo selettore	Pin	Pivot	Bolzen	Perno	
C	7	8000 A0317	1	Perno fermo selettore	Pin	Pivot	Bolzen	Perno	
	8	8000 06597	2	Cuscinetto	Bearing	Roulement	Lager	Cojinete	
XBR	9	8000 42100	1	Piastrina	Plate	Plaque	Plättchen	Placa	
	10	8H00 67545	1	Vite	Screw	Vis	Schraube	Tornillo	
	11	8000 73500	2	Bussola	Bushing	Douille	Buchse	Manguito	
	12	8000 31717	4	Bussola	Bushing	Douille	Buchse	Manguito	
	13	8000 56409	1	Dado	Nut	Ecrou	Mutter	Tuerca	
	14	8000 42185	4	Prigioniero (M10x64 mm)	Stud bolt (M10x64 mm)	Prisonnier (M10x64 mm)	Stiftschraube (M10x64 mm)	Prisionero (M10x64 mm)	
	15	8000 07719	4	Bussola di riferimento	Bushing	Douille	Buchse	Manguito	
	16	8000 32389	1	Anello di tenuta ($\varnothing 20 \times \varnothing 40 \times 7$ mm)	Seal ring ($\varnothing 20 \times \varnothing 40 \times 7$ mm)	Bague d'étanchéité ($\varnothing 20 \times \varnothing 40 \times 7$ mm)	Dichtungsring ($\varnothing 20 \times \varnothing 40 \times 7$ mm)	Anillo de retención ($\varnothing 20 \times \varnothing 40 \times 7$ mm)	
	17	8000 78788	1	Cusc. a sfere alb. primario ($\varnothing 17 \times \varnothing 40 \times 8$ mm)	Ball bearing ($\varnothing 17 \times \varnothing 40 \times 8$ mm)	Roulement à billes ($\varnothing 17 \times \varnothing 40 \times 8$ mm)	Kugellager ($\varnothing 17 \times \varnothing 40 \times 8$ mm)	Cojinete de bolas ($\varnothing 17 \times \varnothing 40 \times 8$ mm)	
	18	8000 59977	1	Anello di tenuta ($\varnothing 32 \times \varnothing 40 \times 5$ mm)	Seal ring ($\varnothing 32 \times \varnothing 40 \times 5$ mm)	Bague d'étanchéité ($\varnothing 32 \times \varnothing 40 \times 5$ mm)	Dichtungsring ($\varnothing 32 \times \varnothing 40 \times 5$ mm)	Anillo de retención ($\varnothing 32 \times \varnothing 40 \times 5$ mm)	
XBR	19	8000 38518	1	Piastrina	Plate	Plaque	Plättchen	Placa	
	20	8A00 28327	2	Vite	Screw	Vis	Schraube	Tornillo	
	21	8000 48209	1	Anello di tenuta ($\varnothing 20 \times \varnothing 28 \times 6$ mm)	Seal ring ($\varnothing 20 \times \varnothing 28 \times 6$ mm)	Bague d'étanchéité ($\varnothing 20 \times \varnothing 28 \times 6$ mm)	Dichtungsring ($\varnothing 20 \times \varnothing 28 \times 6$ mm)	Anillo de retención ($\varnothing 20 \times \varnothing 28 \times 6$ mm)	
	22	8000 02124	1	Cusc. a sfere ($\varnothing 12 \times \varnothing 32 \times 10$ mm)	Ball bearing ($\varnothing 12 \times \varnothing 32 \times 10$ mm)	Roulement à billes ($\varnothing 12 \times \varnothing 32 \times 10$ mm)	Kugellager ($\varnothing 12 \times \varnothing 32 \times 10$ mm)	Cojinete de bolas ($\varnothing 12 \times \varnothing 32 \times 10$ mm)	

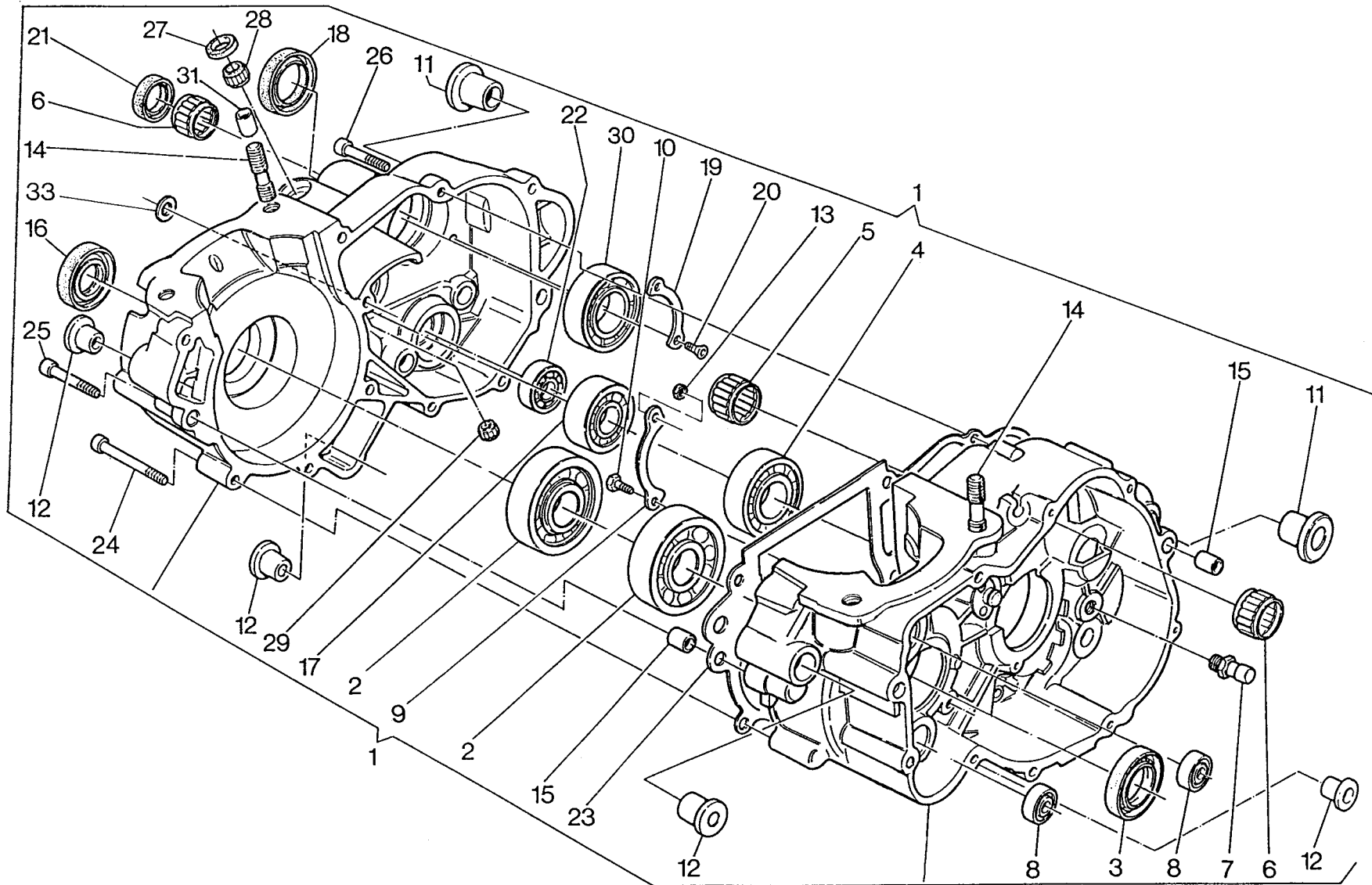

Note Notes Notas	Pos. No. Index Pos.	N. Cod. Code No. Nr. Code Code Nr N. Cod.	Q.tà Q.ty Q.te M.ge C.ad	DENOMINAZIONE	NAME	DESIGNATION	BESHREIBUNG	DENOMINACION	Validità Validity Validité Gültig Validez
	23	8000 72522	1	Guarnizione	Gasket	Garniture	Dichtung	Junta	
	24	60N1 02515	3	Vite (M6x50 mm)	Screw (M6x50 mm)	Vis (M6x50 mm)	Schraube (M6x50 mm)	Tornillo (M6x50 mm)	
	25	60N1 02514	6	Vite (M6x45 mm)	Screw (M6x45 mm)	Vis (M6x45 mm)	Schraube (M6x45 mm)	Tornillo (M6x45 mm)	
	26	60N1 02512	3	Vite (M6x35 mm)	Screw (M6x35 mm)	Vis (M6x35 mm)	Schraube (M6x35 mm)	Tornillo (M6x35 mm)	
	27	8000 48856	1	Anello di tenuta (\varnothing 13x \varnothing 20x4 mm)	Seal ring (\varnothing 13x \varnothing 20x4 mm)	Bague d'étanchéité (\varnothing 13x \varnothing 20x4 mm)	Dichtungsring (\varnothing 13x \varnothing 20x4 mm)	Anillo de retención (\varnothing 13x \varnothing 20x4 mm)	
	28	8000 49016	1	Cuscinetto a rullini (\varnothing 13x \varnothing 19x12 mm)	Needle bearing (\varnothing 13x \varnothing 19x12 mm)	Roulement à aiguilles (\varnothing 13x \varnothing 19x12 mm)	Nadelkäfig (\varnothing 13x \varnothing 19x12 mm)	Cojinete de rodillos (\varnothing 13x \varnothing 19x12 mm)	
	29	8000 42244	1	Cuscinetto a rullini (\varnothing 7x \varnothing 11x9 mm)	Needle bearing (\varnothing 7x \varnothing 11x9 mm)	Roulement à aiguilles (\varnothing 7x \varnothing 11x9 mm)	Nadelkäfig (\varnothing 7x \varnothing 11x9 mm)	Cojinete de rodillos (\varnothing 7x \varnothing 11x9 mm)	
	30	8000 43789	1	Cusc. a rulli albero secondario (\varnothing 25x \varnothing 52x15 mm)	Ball bearing (\varnothing 25x \varnothing 52x15 mm)	Roulement à billes (\varnothing 25x \varnothing 52x15 mm)	Kugellager (\varnothing 25x \varnothing 52x15 mm)	Cojinete de bolas (\varnothing 25x \varnothing 52x15 mm)	
	31	8000 19979	2	Bussola	Bushing	Douille	Buchse	Manguito	
	33	1610 82301	1	Rosetta	Washer	Rondelle	Scheibe	Arandela	

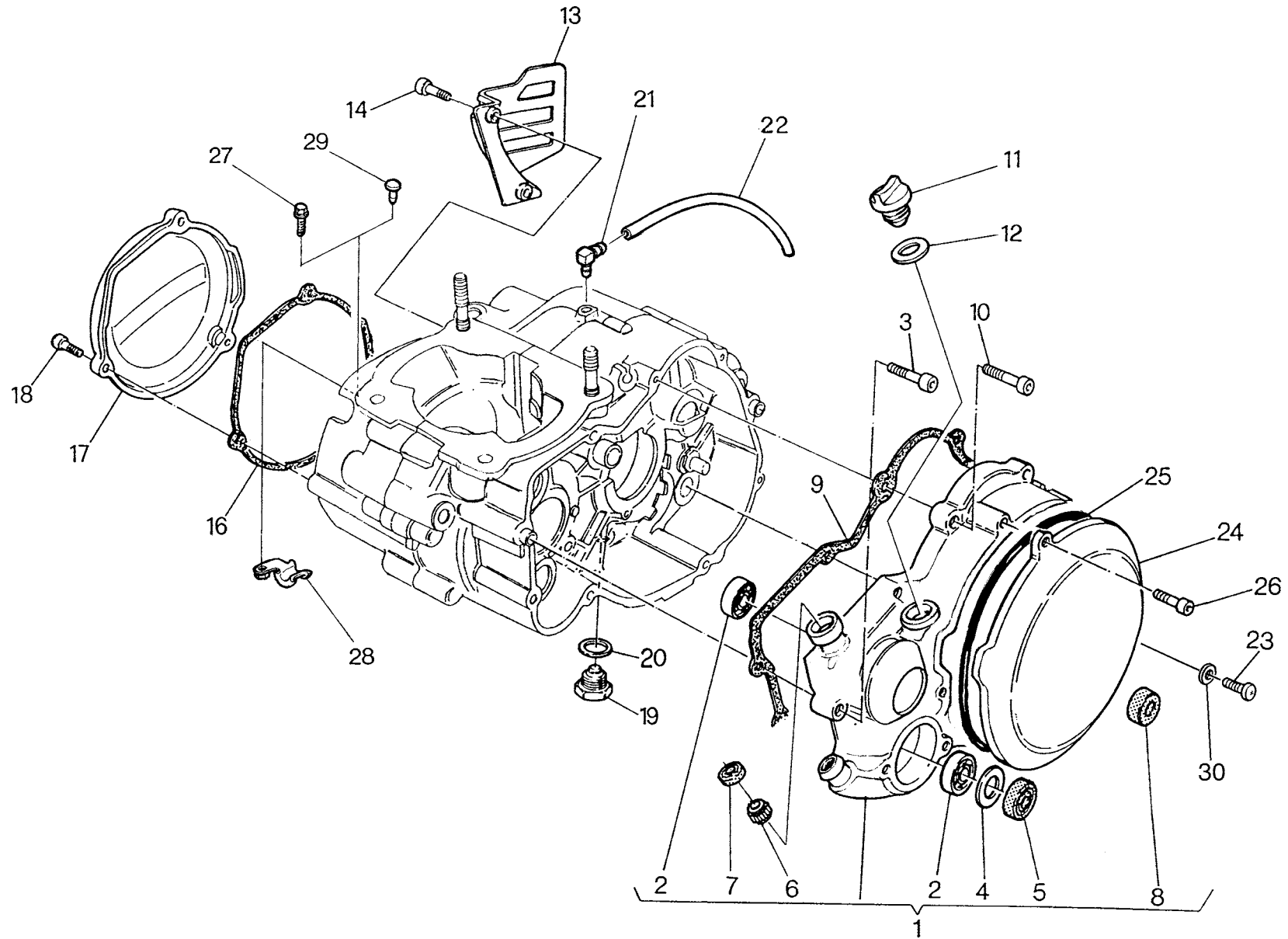

Note Notes Notas	Pos. No. N. Index Pos.	N. Cod. Code No. Nr. Code Code Nr N. Cod.	Q.tà Q.ty Q.te M.ge C.ad	DENOMINAZIONE	NAME	DESIGNATION	BESHREIBUNG	DENOMINACION	Validità Validity Validité Gültig Validez
	1	80A0 86875	1	Coperchio sinistro completo	Left cover assembly	Ensemble couvercle G.	Aggregat Dekel L.	Juego tapa izq.	
	2	8000 06597	2	Cuscinetto a sfere	Ball bearing (ø8xØ22x7 mm)	Roulement à billes	Kugellager (ø8xØ22x7 mm)	Cojinete de bolas	
	3	8A00 67545	2	Vite (M6x35 mm)	Screw (M6x35 mm)	Vis (M6x35 mm)	Schraube (M6x35 mm)	Tornillo (M6x35 mm)	
	4	8000 44978	1	Rosetta piana	Washer	Rondelle	Scheibe	Arandela	
	5	8000 38215	1	Anello di tenuta (ø15xØ24x7 mm)	Seal ring (ø15xØ24x7 mm)	Bague d'étanchéité (ø15xØ24x7 mm)	Dichtungsring (ø15xØ24x7 mm)	Anillo de retención (ø15xØ24x7 mm)	
	6	8000 47678	2	Cuscinetto a rullini	Needle bearing	Roulement à aiguilles	Nadelkäfig	Cojinete de rodillos	
	7	8000 19177	1	Anello di tenuta (ø8xØ13x3,5 mm)	Seal ring (ø8xØ13x3,5 mm)	Bague d'étanchéité (ø8xØ13x3,5 mm)	Dichtungsring (ø8xØ13x3,5 mm)	Anillo de retención (ø8xØ13x3,5 mm)	
	8	8000 34451	1	Anello di tenuta (ø12xØ19x5 mm)	Seal ring (ø12xØ19x5 mm)	Bague d'étanchéité (ø12xØ19x5 mm)	Dichtungsring (ø12xØ19x5 mm)	Anillo de retención (ø12xØ19x5 mm)	
	9	8000 48216	1	Guarnizione	Gasket	Garniture	Dichtung	Junta	
	10	8000 62729	6	Vite (M6x25 mm)	Screw (M6x25 mm)	Vis (M6x25 mm)	Schraube (M6x25 mm)	Tornillo (M6x25 mm)	
	11	8000 36786	1	Tappo carico olio	Oil filling cap	Bouchon rempl. huile	Öleinfüllstöpsel	Tapón intruducción aceite	
	12	8000 27960	1	Rosetta di tenuta	Washer	Rondelle	Scheibe	Arandela	
	13	8000 82939	1	Coperchio pignone	Cover	Couvercle	Deckel	Tapa	
	14	8000 62727	2	Vite (M6x16 mm)	Screw (M6x16 mm)	Vis (M6x16 mm)	Schraube (M6x16 mm)	Tornillo (M6x16 mm)	
	16	8000 69372	1	Guarnizione	Gasket	Garniture	Dichtung	Junta	
	17	80B0 82930	1	Coperchio volano	Cover	Couvercle	Deckel	Tapa	
	18	8000 62728	3	Vite (M6x20 mm)	Screw (M6x20 mm)	Vis (M6x20 mm)	Schraube (M6x20 mm)	Tornillo (M6x20 mm)	
	19	8000 11524	1	Tappo scarico olio	Oil drain plug	Bouchon vidange huile	Stöpsel f. ölablass	Tapón purga aceite	
	20	8B00 06725	1	Rosetta di tenuta	Washer	Rondelle	Scheibe	Arandela	
	21	8000 19620	1	Raccordo sfiato camera cambio	Union	Raccord	Anschluss	Empalme	
	22	8000 45022	1	Tubo	Pipe	Tuyau	Rohr	Tubo	
	23	8000 35099	1	Vite	Screw	Vis	Schraube	Tornillo	
	24	80B0 96560	1	Coperchio frizione	Clutch cover	Couvercle embrayage	Kupplungsdeckel	Tapa accion. embrague	
	25	8000 86878	1	Guarnizione	Gasket	Garniture	Dichtung	Junta	
	26	8000 62728	5	Vite (M6x20 mm)	Screw (M6x20 mm)	Vis (M6x20 mm)	Schraube (M6x20 mm)	Tornillo (M6x20 mm)	
Y	27	8E00 67997	1	Vite	Screw	Vis	Schraube	Tornillo	
Y	28	8000 89353	1	Piastrina	Plate	Plaque	Plättchen	Placa	
C	29	8000 58394	1	Tappo	Plug	Bouchon	Verschluss	Tapa	
	30	8000 64988	1	Guarnizione	Gasket	Garniture	Dichtung	Junta	

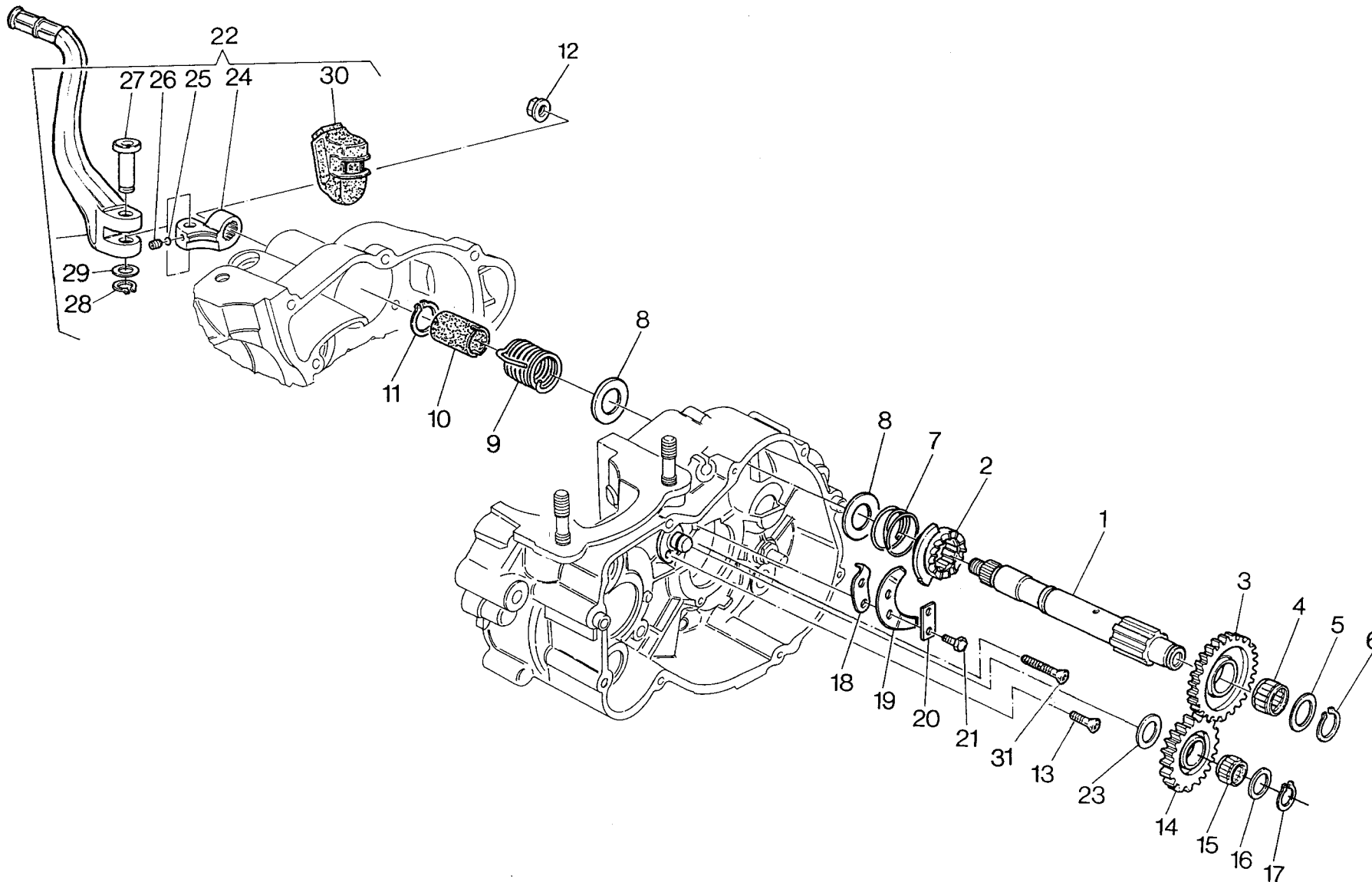

Note Notes Notas	Pos. No. N. Index Pos.	N. Cod. Code No. Nr. Code Code Nr N. Cod.	Q.tà Q.ty Q.te M.ge C.ad	DENOMINAZIONE	NAME	DESIGNATION	BESHREIBUNG	DENOMINACION	Validità Validity Validité Gültig Validez
	1	8000 90617	1	Albero avviamento	Starter crank shaft	Arbre de démarrage	Kickstarterwelle	Eje arranque	
	2	8000 48111	1	Manicotto scorrevole	Sleeve	Manchon	Muffe	Manguito	
	3	8000 48112	1	Ingr. con cricchetto (Z = 27)	Gear (Z = 27)	Engrantage (Z = 27)	Zahnrad (Z = 27)	Engranaje (Z = 27)	
	4	8000 48113	1	Cuscinetto a rullini (ø18xØ22x8 mm)	Needle bearing (ø18xØ22x8 mm)	Roulement à aiguilles (ø18xØ22x8 mm)	Nadelkäfig (ø18xØ22x8 mm)	Cojinete de rodillos (ø18xØ22x8 mm)	
	5	8000 48114	1	Rosetta di rasamento	Washer	Rondelle	Scheibe	Arandela	
	6	66N0 21207	1	Anello elastico	Split ring	Anneau ressort	Sprengring	Anillo elástico	
	7	8000 48115	1	Molla	Spring	Ressort	Feder	Resorte	
	8	8E00 32069	2	Rosetta di rasamento (1,0 mm)	Washer (1,0 mm)	Rondelle (1,0 mm)	Scheibe (1,0 mm)	Arandela (1,0 mm)	
	8	8D00 32069	2	Rosetta di rasamento (0,8 mm)	Washer (0,8 mm)	Rondelle (0,8 mm)	Scheibe (0,8 mm)	Arandela (0,8 mm)	
	8	8000 32069	2	Rosetta di rasamento (0,3 mm)	Washer (0,3 mm)	Rondelle (0,3 mm)	Scheibe (0,3 mm)	Arandela (0,3 mm)	
	9	8000 48116	1	Molla	Spring	Ressort	Feder	Resorte	
	10	8000 48117	1	Distanziale	Spacer	Entretoise	Distanzstück	Separador	
	11	66N0 21208	1	Anello elastico	Split ring	Anneau ressort	Sprengring	Anillo elástico	
	12	8000 38624	1	Dado	Nut	Ecrou	Mutter	Tuerca	
	13	8000 28327	1	Vite	Screw	Vis	Schraube	Tornillo	
	14	8000 57542	1	Ingranaggio di rinvio (Z = 20)	Gear (Z = 20)	Engrantage (Z = 20)	Zahnrad (Z = 20)	Engranaje (Z = 20)	
	15	8000 31773	1	Cuscinetto a rullini (ø16xØ20x8 mm)	Needle bearing (ø16xØ20x8 mm)	Roulement à aiguilles (ø16xØ20x8 mm)	Nadelkäfig (ø16xØ20x8 mm)	Cojinete de rodillos (ø16xØ20x8 mm)	
	16	8A00 38110	1	Rosetta di rasamento (0,4 mm)	Washer (0,4 mm)	Rondelle (0,4 mm)	Scheibe (0,4 mm)	Arandela (0,4 mm)	
	16	8D00 38110	1	Rosetta di rasamento (0,8 mm)	Washer (0,8 mm)	Rondelle (0,8 mm)	Scheibe (0,8 mm)	Arandela (0,8 mm)	
	17	66N0 21205	1	Anello elastico	Split ring	Anneau ressort	Sprengring	Anillo elástico	
	18	8000 31695	1	Piastrina fine corsa	Plate	Plaquette	Plättchen	Placa final de carrera	
	19	8000 55536	1	Piastrina disinnesto	Plate	Plaquette	Plättchen	Placa	
	20	8000 20474	1	Piastrina di sicurezza	Plate	Plaquette	Plättchen	Placa	
	21	60N1 01883	2	Vite	Screw	Vis	Schraube	Tornillo	
	22	8000 89996	1	Leva avviamento compl.	Starter lever assy	Lev. démarrage compl.	Hebelanlasser kpl.	Pal. arranque compl.	
	23	8000 38110	1	Rosetta di rasamento (0,3 mm)	Washer (0,3 mm)	Rondelle (0,3 mm)	Scheibe (0,3 mm)	Arandela (0,3 mm)	
	23	8B00 38110	1	Rosetta di rasamento (0,5 mm)	Washer (0,5 mm)	Rondelle (0,5 mm)	Scheibe (0,5 mm)	Arandela (0,5 mm)	
	24	8000 89998	1	Mozzetto	Hub	Moyeau	Radnabe	Cubo	
	25	6BN0 21507	1	Sfera (1/4")	Ball (1/4")	Bille (1/4")	Kugel (1/4")	Esfera (1/4")	
	26	8000 32203	1	Molla	Spring	Ressort	Feder	Resorte	
	27	8000 38622	1	Perno	Pin	Pivot	Bolzen	Perno	

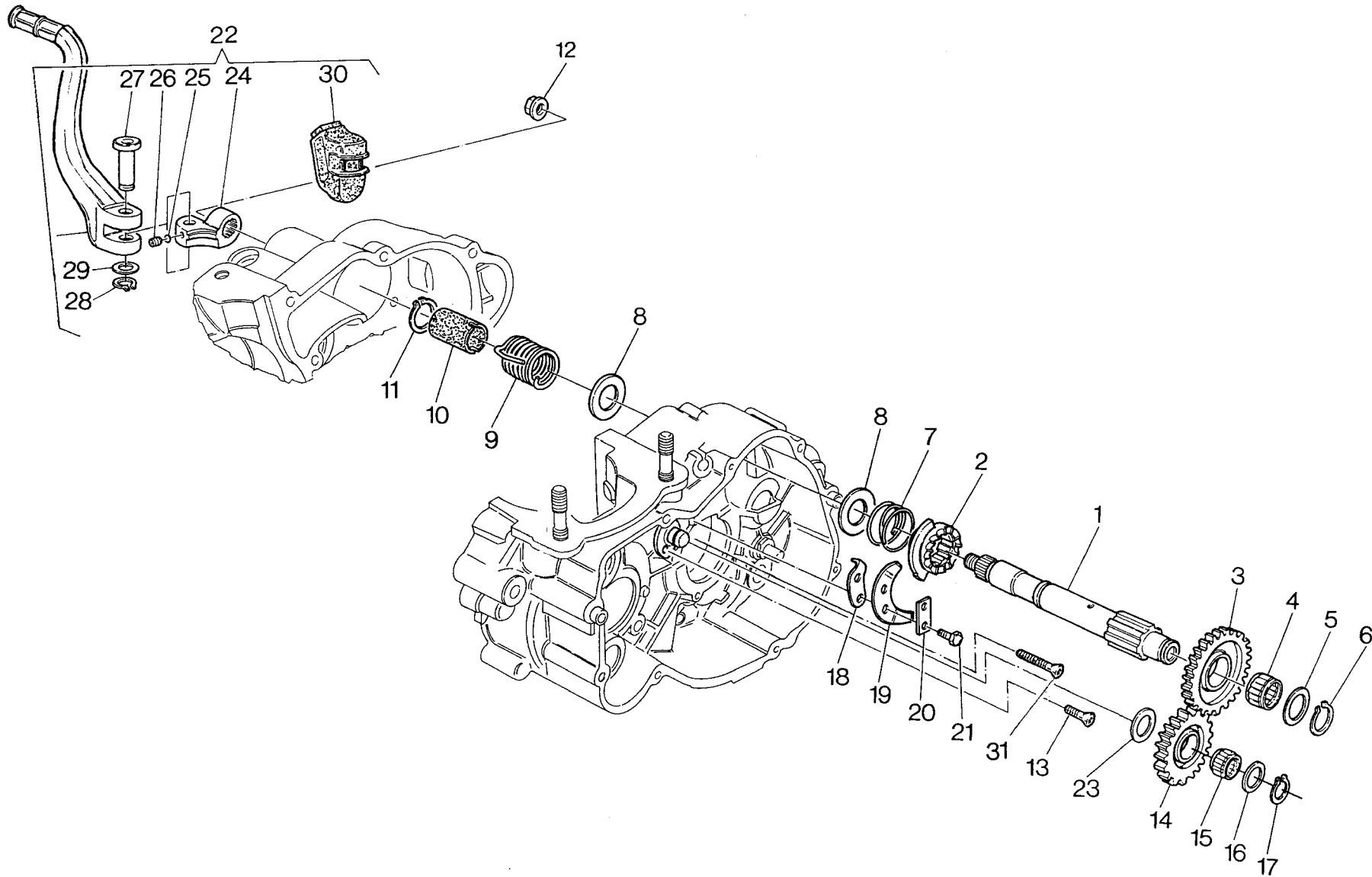

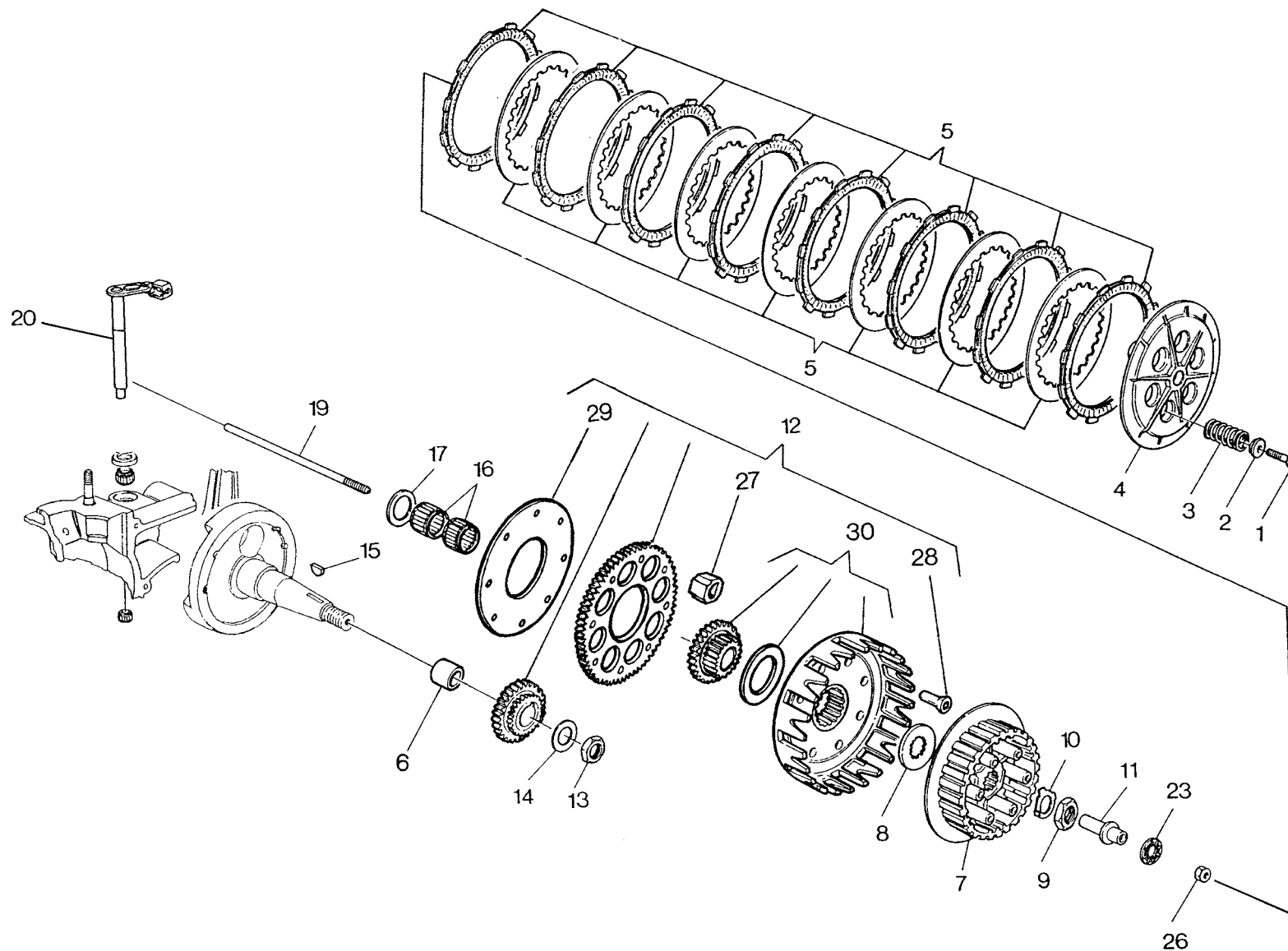

Note Notes Notas	Pos. No. Index Pos.	N. Cod. Code No. Nr. Code Code Nr N. Cod.	Q.tà Q.ty Q.te M.ge C.ad	DENOMINAZIONE	NAME	DESIGNATION	BESHREIBUNG	DENOMINACION	Validità Validity Validité Gültig Validez
	1	8000 62728	6	Vite	Screw	Vis	Schraube	Tornillo	
	2	8A00 39248	6	Piattello	Plate	Plateau	Teller	Placa	
	3	8000 86880	6	Molla	Spring	Ressort	Feder	Resorte	
	4	8000 48138	1	Piatto spingidisci	Pressure plate	Pousse disque	Druckplatte	Plato empuja-disco	
	5	8000 88966	1	Ass. gruppo frizione	Clutch group assy	Groupe embrayage compl.	Kupplungsgruppe Kpl.	Grupo embrague compl.	
	6	8A00 82467	1	Distanziale	Spacer	Entretoise	Distanzstück	Separadør	
	7	8000 85390	1	Mozzo portadisci	Clutch hub	Moyeu porte-disque	Scheibenthalernabe	Porta-discos	
	8	8000 38350	1	Rosetta di spallamento	Washer	Rondelle	Scheibe	Arandela	
	9	8000 36856	1	Dado	Nut	Ecrou	Mutter	Tuerca	
	10	8000 36857	1	Rosetta di sicurezza	Washer	Rondelle	Scheibe	Arandela	
	11	8000 99819	1	Piattello	Plate	Plateau	Teller	Placa	
E	12	8000 86860	1	Coppia ingranaggi trasmissione primaria (z 27/69)	Set of matched primary (z 27/69)	Engrenages transmission primarie (z 27/69)	Stirnraderpaar (z 27/69)	Copla engranaje transmisiòn primaria (z 27/69)	
	12	8000 97137	1	Coppia ingranaggi trasmissione primaria (z 27/69)	Set of matched primary (z 27/69)	Engrenages transmission primarie (z 27/69)	Stirnraderpaar (z 27/69)	Copla engranaje transmisiòn primaria (z 27/69)	
	13	8000 36856	1	Dado	Nut	Ecrou	Mutter	Tuerca	
	14	8000 48238	1	Rosetta a tazza	Washer	Rondelle	Scheibe	Arandela	
	15	65N0 21010	1	Linguetta americana	Woodruff key	Clé woodruff	Federkeil	Lengüeta americana	
	16	8000 25044	2	Gabbia a rullini	Needle cage	Cage à aiguilles	Nadelkaefig	Jaula de agujas del cojinete	
	17	8000 48239	1	Rosetta di rasamento (1,1 mm)	Washer (1,1 mm)	Rondelle (1,1 mm)	Scheibe (1,1 mm)	Arandela (1,1 mm)	
	17	8A00 48239	1	Rosetta di rasamento (1,3 mm)	Washer (1,3 mm)	Rondelle (1,3 mm)	Scheibe (1,3 mm)	Arandela (1,3 mm)	
	17	8B00 48239	1	Rosetta di rasamento (1,5 mm)	Washer (1,5 mm)	Rondelle (1,5 mm)	Scheibe (1,5 mm)	Arandela (1,5 mm)	
	19	8000 A0610	1	Astina disinnesto	Control rod	Coulisseau	Steuerstange	Varilla	
	20	8000 A0336	1	Albero comando frizione	Shaft	Arbre	Welle	Eje	
	23	8000 35780	1	Cuscinetto assiale	Bearing	Roulement	Lager	Cojinete	
	26	60N1 15033	1	Dado	Nut	Ecrou	Mutter	Tuerca	
	27	8000 48235	8	Parastrappi	Flexible coupling	Piece caoutchouch	Gumidämpfer	Paratirones	
	28	8000 48236	8	Ribattino	Rivet	Rivet	Niet	Remache	
	29	8000 48234	1	Disco ritegno ingr. condotto	Drive gear retaining disc	Disque	Scheibe	Disco	

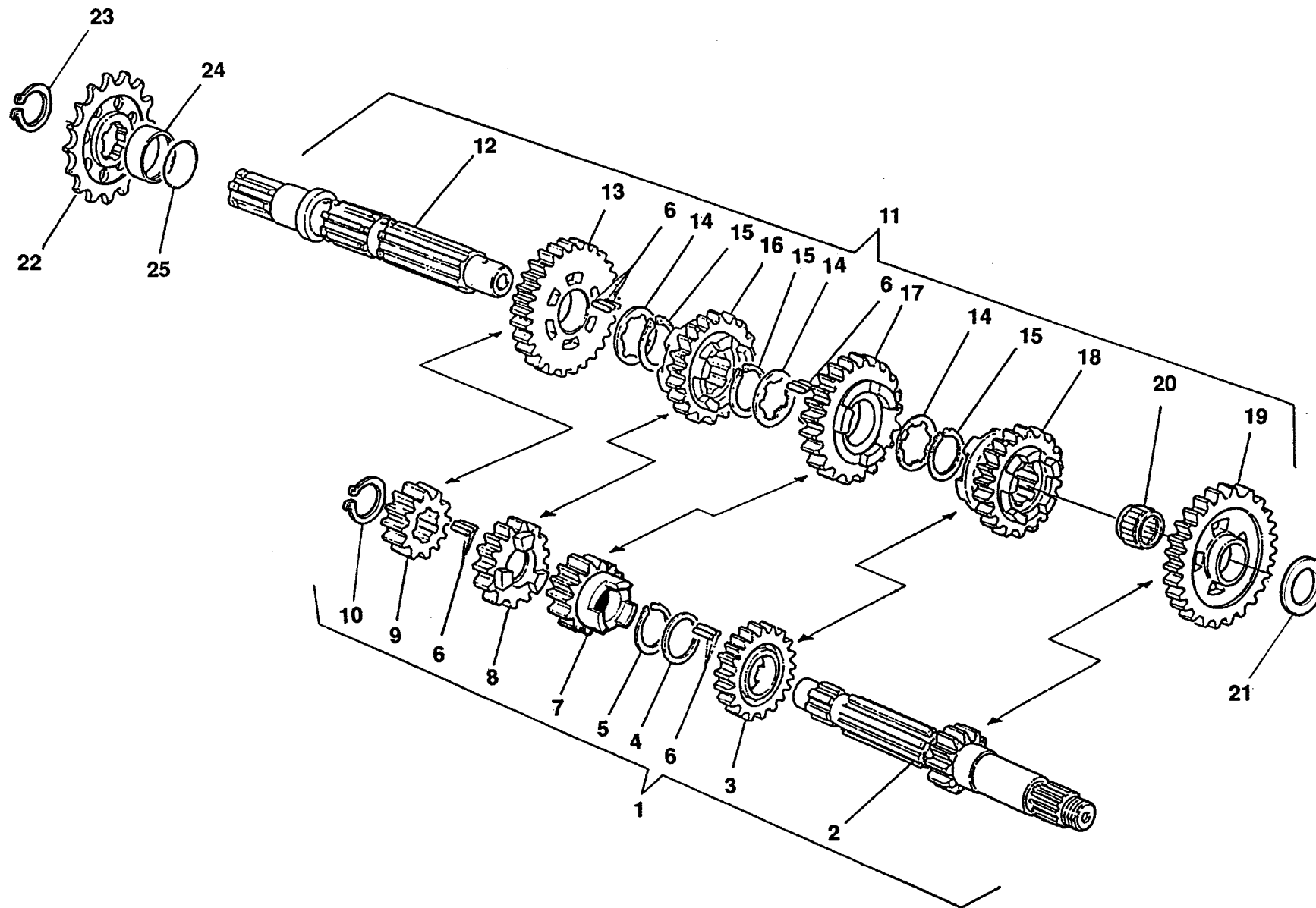

Note Notes Notas	Pos. No. Index Pos.	N. Cod. Code No. Nr. Code Code Nr N. Cod.	Q.tà Q.ty Q.te M.ge C.ad	DENOMINAZIONE	NAME	DESIGNATION	BESHREIBUNG	DENOMINACION	Validità Validity Validité Gültig Validez
	1	8000 86884	1	Albero primario completo	Main shaft	Arbre primaire	Hauptwelle	Eje principal completo	
	2	8000 86885	1	Albero primario (Z=14)	Main shaft (Z=14)	Arbre primaire (Z=14)	Hauptwelle (Z=14)	Eje primario (Z=14)	
	3	8000 60944	1	Ingr. 5ª velocità (Z=19)	Gear 5th speed (Z=19)	Engrange 5ème (Z=19)	Zahnrad 5. Gang (Z=19)	Engranaje 5° velocid.(Z=19)	
	4	8A00 54319	1	Rosetta di rasamento (1,2 mm)	Washer (1,2 mm)	Rondelle (1,2 mm)	Scheibe (1,2 mm)	Arandela (1,2 mm)	
	5	8000 31772	1	Anello elastico	Split ring	Anneau ressort	Sprengring	Anillo elástico	
	6	8000 27690	144	Rullino	Roller	Aiguille	Rolle	Rodillo	
	7	8000 60947	1	Ingr. 3ª velocità (Z=16)	Driven gear 3rd speed (Z=16)	Engr. conduit 3 ème (Z=16)	Zahnrad 3. Gang (Z=16)	Engr. 3° velocidad (Z=16)	
	8	8000 86990	1	Ingr. 4ª vel. (Z=19)	4th speed gear (Z=19)	Engrange 4ème (Z=19)	Zahnrad 4. Gang (Z=19)	Engr. 4° velocidad (Z=19)	
	9	8000 86886	1	Ingr. 2ª vel. (Z=16)	2nd speed gear (Z=16)	Engrange 2ème (Z=16)	Zahnrad 2. Gang (Z=16)	Engr. 2° velocidad (Z=16)	
	10	66N0 21209	1	Anello elastico	Split ring	Anneau ressort	Sprengring	Anillo elástico	
	11	8000 86994	1	Albero secondario completo	Layshaft compl.	Arbre secondaire compl.	Vorgelegewelle kpl.	Eje secundario compl.	
	12	8000 86995	1	Albero secondario	Layshaft	Arbre secondaire	Vorgelegewelle	Eje secundario	
	13	8000 82929	1	Ingr. 2ª vel. (Z=28)	2nd speed gear (Z=28)	Engrange 2ème (Z=28)	Zahnrad 2. Gang (Z=28)	Engr. 2° velocidad (Z=28)	
	14	8A00 36889	3	Rosetta di rasamento (1,2 mm)	Washer (1,2 mm)	Rondelle (1,2 mm)	Scheibe (1,2 mm)	Arandela (1,2 mm)	
	15	8000 36888	3	Anello elastico	Split ring	Anneau ressort	Sprengring	Anillo elástico	
	16	8000 86991	1	Ingr. 4ª vel. (Z=23)	4th speed gear (Z=23)	Engrange 4ème (Z=23)	Zahnrad 4. Gang (Z=23)	Engr. 4° velocidad (Z=23)	
	17	8000 60951	1	Ingr. 3ª vel. (Z=23)	3rd speed gear (Z=23)	Engrange 3ème (Z=23)	Zahnrad 3. Gang (Z=23)	Engranaje 3° velocid.(Z=23)	
	18	8000 82931	1	Ingr. 5ª vel. (Z=20)	Gear 5th speed (Z=20)	Engrange 5ème (Z=20)	Zahnrad 5. Gang (Z=20)	Engranaje 5° velocid.(Z=20)	
	19	8000 82928	1	Ingr. 1ª vel. (Z=30)	Gear 1st speed (Z=30)	Engrange 1ère (Z=30)	Zahnrad 1. Gang (Z=30)	Engranaje 1° velocid.(Z=30)	
	20	8000 22373	1	Cuscinetto a rullini (ø20xØ24x10 mm)	Needle bearing (ø20xØ24x10 mm)	Roulement à aiguilles (ø20xØ24x10 mm)	Nadelkäfig (ø20xØ24x10 mm)	Cojinete de rodillos (ø20xØ24x10 mm)	
	21	8E00 07989	1	Rosetta di rasamento (0,8 mm)	Washer (0,8 mm)	Rondelle (0,8 mm)	Scheibe (0,8 mm)	Arandela (0,8 mm)	
	21	8G00 07989	1	Rosetta di rasamento (1,0 mm)	Washer (1,0 mm)	Rondelle (1,0 mm)	Scheibe (1,0 mm)	Arandela (1,0 mm)	
	21	8I00 07989	1	Rosetta di rasamento (1,2 mm)	Washer (1,2 mm)	Rondelle (1,2 mm)	Scheibe (1,2 mm)	Arandela (1,2 mm)	
S	22	8000 63828	1	Pignone uscita cambio (Z= 13)	Pinion (Z= 13)	Pignon (Z= 13)	Ritzel (Z= 13)	Piñón (Z= 13)	
R	22	8000 63829	1	Pignone uscita cambio (Z= 14)	Pinion (Z= 14)	Pignon (Z= 14)	Ritzel (Z= 14)	Piñón (Z= 14)	
R	22	8000 63830	1	Pignone uscita cambio (Z= 15)	Pinion (Z= 15)	Pignon (Z= 15)	Ritzel (Z= 15)	Piñón (Z= 15)	
	22	66N0 21211	1	Anello SEEGER	SEEGER ring	Anneau SEEGER	Ring SEEGER	Anillo SEEGER	
	24	8000 60464	1	Distanziale	Spacer	Entretoise	Distanzstück	Separador	
	25	8000 23110	1	Anello OR	O Ring	Bague OR	O Ring	Anillo OR	

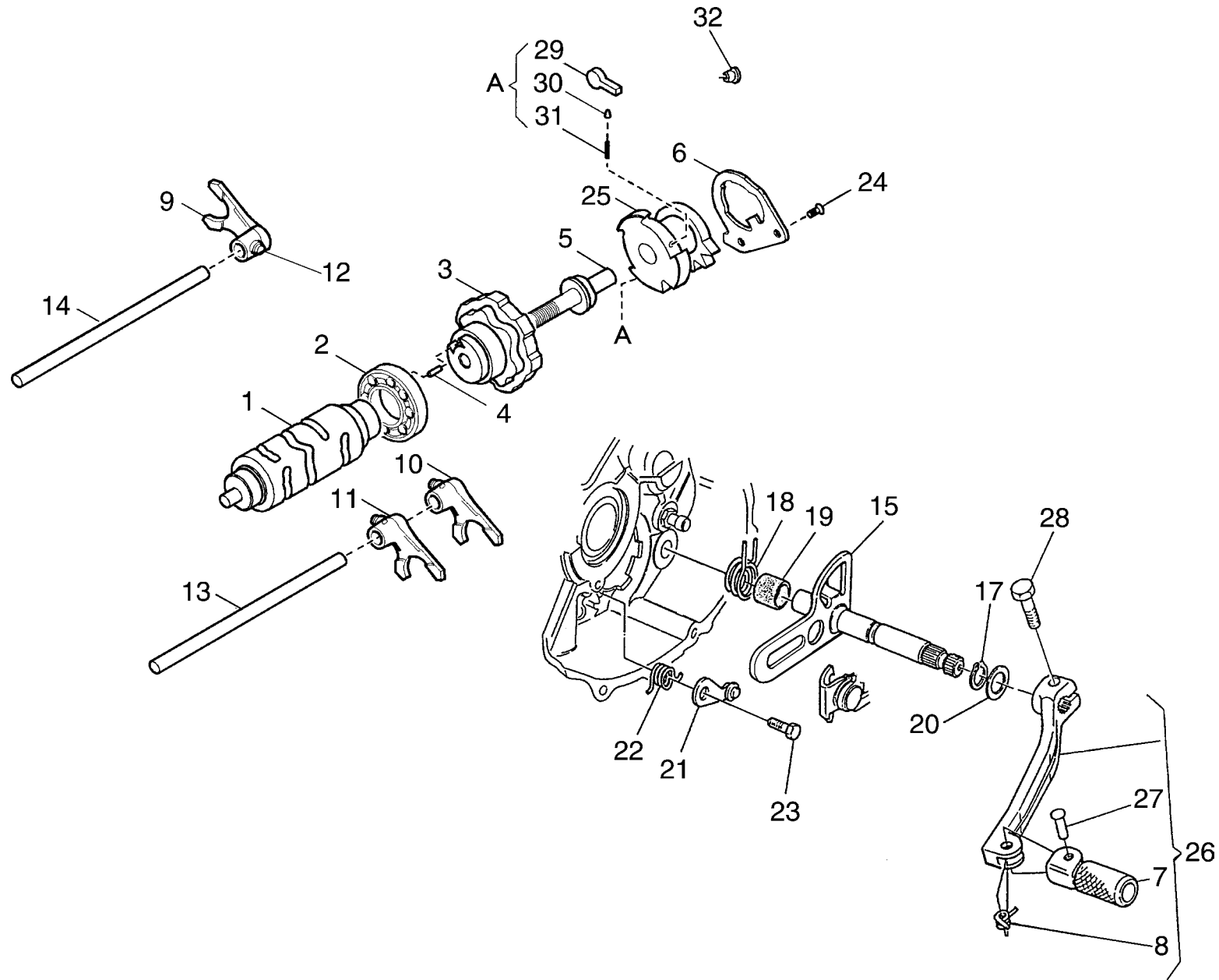

Note Notes Notas	Pos. No. N. Index Pos.	N. Cod. Code No. Nr. Code Code Nr N. Cod.	Q.tà Q.ty Q.te M.ge C.ad	DENOMINAZIONE	NAME	DESIGNATION	BESHREIBUNG	DENOMINACION	Validità Validity Validité Gültig Validez
	1	8000 A0316	1	Albero com. forcelle cambio	Driving shaft gearbox forks	Arbre comm. fourches trans.	Antriebswelle Schaltgabel	Eje mando horquilla cambio	
	2	8000 85395	1	Cuscinetto a sfere (ø25xø42x9)	Ball bearing (ø25xø42x9)	Roulement à billes	Kugellager (ø25xø42x9)	Cojinete de bolas	
	3	8A00 97739	1	Tamburo selettore marce	Drum	Tambour	Trommel	Tambor	
	4	8000 38520	1	Rullino	Roller	Aiguille	Rolle	Rodillo	
	5	8000 98149	1	Vite	Screw	Vis	Schraube	Tornillo	
	6	8000 A0322	1	Piastrina	Plate	Plaque	Platte	Placa	
	7	8000 70215	1	Pedalino	Pedal	Pedale	Pedal	Pedal	
	8	8000 70216	1	Molla	Spring	Ressort	Feder	Remache	
	9	8000 48125	1	Forcella cambio (4a-5a)	Fork gearchange (4th-5h)	Fourche boite a vitesse	Gabel Schaltung	Horquilla cambio	
	10	8000 86980	1	Forcella cambio (1a-3a)	Fork gearchange (1st-3rd)	Fourche boite a vitesse	Gabel Schaltung	Horquilla cambio	
	11	8000 48127	1	Forcella cambio (2a)	Fork gearchange (2nd)	Fourche boite a vitesse	Gabel Schaltung	Horquilla cambio	
	12	8000 38728	3	Rullino	Roller	Aiguille	Rolle	Rodillo	
	13	8000 38711	1	Perno (L=96 mm)	Pin (L=96 mm)	Pivot (L=96 mm)	Bolzen (L=96 mm)	Perno (L=96 mm)	
	14	8000 38712	1	Perno (L=57,5 mm)	Pin (L=57,5 mm)	Pivot (L=57,5 mm)	Bolzen (L=57,5 mm)	Perno (L=57,5 mm)	
	15	8000 A0320	1	Albero com. selettore	Gearbox pedal shaft assy	Arbre péd. change vit. compl.	Pedal Umsteuerungswelle kpl.	Eje pedal cambio compl.	
	17	66N0 21202	1	Anello elastico	Split ring	Anneau ressort	Sprengring	Anillo elástico	
	18	8000 46225	1	Molla	Spring	Ressort	Feder	Resorte	
	19	8B00 46226	1	Bussola	Bushing	Douille	Buchse	Manguito	
	20	8D00 01261	1	Rosetta	Washer	Rondelle	Scheibe	Arandela	
	21	8000 A0323	1	Saltarello	Click	Cliquet	Strumhaken	Salt.	
	22	8000 A0590	1	Molla	Spring	Ressort	Feder	Resorte	
	23	8000 A0324	1	Vite	Screw	Vis	Schraube	Tornillo	
	24	8A00 28327	2	Vite	Screw	Vis	Schraube	Tornillo	
	25	8000 A0318	1	Rocchetto selettore dentato	Sprocket	Rochet	Spule	Piñon	
	26	8000 88969	1	Pedale comando cambio compl.	Crank lever assy	Levier compl.	Hebel kpl.	Pedal mando cambio compl.	
	27	8000 70217	1	Ribattino	Rivet	Rivet	Niet	Remache	
	28	8000 62728	1	Vite	Screw	Vis	Schraube	Tornillo	
	29	8000 71007	2	Saltarello per rocchetto	Click	Cliquet	Strumhaken	Salt.	
	30	8000 71008	2	Puntale per saltarello	Push rod	Embout	Stösselschaft	Puntal	
	31	8000 71009	2	Molla	Spring	Ressort	Feder	Resorte	
	32	8000 71010	1	Bussola	Bushing	Douille	Buchse	Manguito	

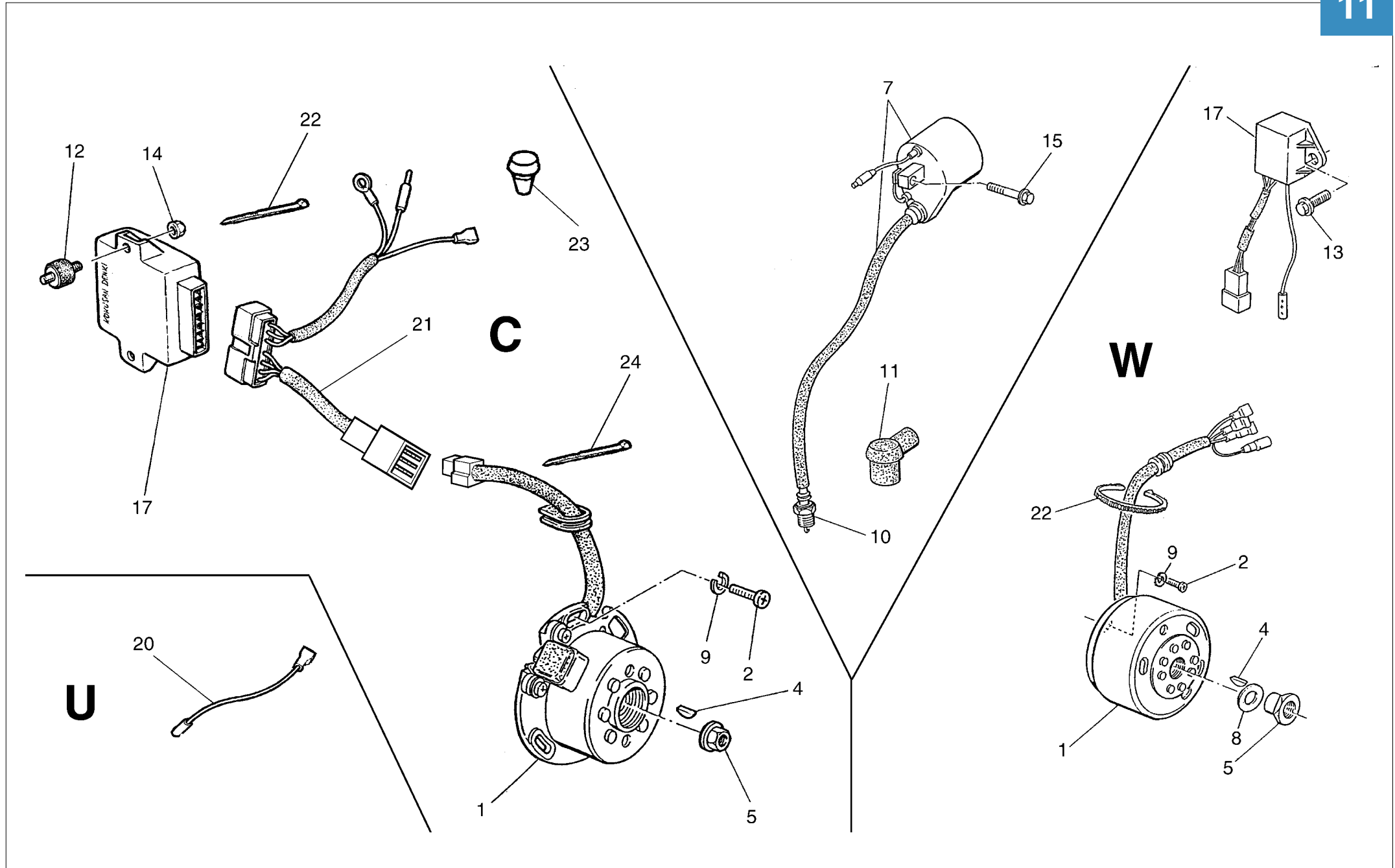

Note Notes Notas	Pos. No. Index Pos.	N. Cod. Code No. Nr. Code Code Nr N. Cod.	Q.tà Q.ty Q.te M.ge C.ad	DENOMINAZIONE	NAME	DESIGNATION	BESHREIBUNG	DENOMINACION	Validità Validity Validité Gültig Validez
W	1	8A00 75347	1	Alternatore completo	Alternator compl.	Alternateur compl.	Lichtmaschine kpl.	Alternador compl.	
C	1	8000 91952	1	Alternatore completo	Alternator compl.	Alternateur compl.	Lichtmaschine kpl.	Alternador compl.	
W	2	8000 82496	2	Vite	Screw	Vis	Schraube	Tornillo	
C	2	8000 62727	2	Vite	Screw	Vis	Schraube	Tornillo	
	4	65N0 21002	1	Linguetta americana	Woodruff key	Clé woodruff	Federkeil	Lengüeta americana	
W	5	8000 73540	1	Dado	Nut	Ecrou	Mutter	Tuerca	
C	5	8000 42023	1	Dado	Nut	Ecrou	Mutter	Tuerca	
W	7	8000 75346	1	Bobina	Coil	Bobine	Zündspule	Bobina	
C	7	8000 72887	1	Bobina	Coil	Bobine	Zündspule	Bobina	
W	8	8000 73593	1	Rosetta	Washer	Rondelle	Scheibe	Arandela	
W	9	8000 38291	2	Rosetta elastica	Washer	Rondelle	Scheibe	Arandela	
C	9	62N1 15504	2	Rosetta elastica	Washer	Rondelle	Scheibe	Arandela	
W	10	8000 76016	1	Candela	Spark plug	Bougie	Zundkerze	Bujías	
C	10	8B00 57446	1	Candela	Spark plug	Bougie	Zundkerze	Bujías	
	11	8000 75270	1	Pipetta schermata	Plug pipe	Pipette bougie	Kerzenstecker	Pipa bujía	
C	12	8000 90012	2	Supporto elastico	Elastic support	Suppport	Halterung	Soporte	
W	13	8000 62725	2	Vite	Screw	Vis	Schraube	Tornillo	
C	14	8000 44240	2	Dado	Nut	Ecrou	Mutter	Tuerca	
	15	8000 62727	2	Vite	Screw	Vis	Schraube	Tornillo	
W	17	8000 75343	1	Centralina elettronica	Electronic device	Dispositif électronique	Zundelektronik	Centralita electronica	
C	17	8000 91953	1	Centralina elettronica	Electronic device	Dispositif électronique	Zundelektronik	Centralita electronica	
U	20	8000 80145	1	Cavo regolatore-bobina	Voltage rectifier-coil cable	Cable regulateur-bobine	Kabel Spannungregler	Cable regulator-bobina	
C	21	8000 91962	1	Gruppo cavi	Cable assy	Cables compl.	Kabel Kpl.	Grupo cables	
W	22	8000 56444	4	Fascetta (L=188 mm)	Clamp (L=188 mm)	Collier (L=188 mm)	Schelle (L=188 mm)	Banda (L=188 mm)	
C	22	8000 56444	5	Fascetta (L=188 mm)	Clamp (L=188 mm)	Collier (L=188 mm)	Schelle (L=188 mm)	Banda (L=188 mm)	
C	23	8000 58394	1	Tampone	Pad	Tampon	Stopfen	Tampón	
C	24	8000 92248	2	Fascetta (L=82 mm)	Clamp (L=82 mm)	Collier (L=82 mm)	Schelle (L=82 mm)	Banda (L=82 mm)	

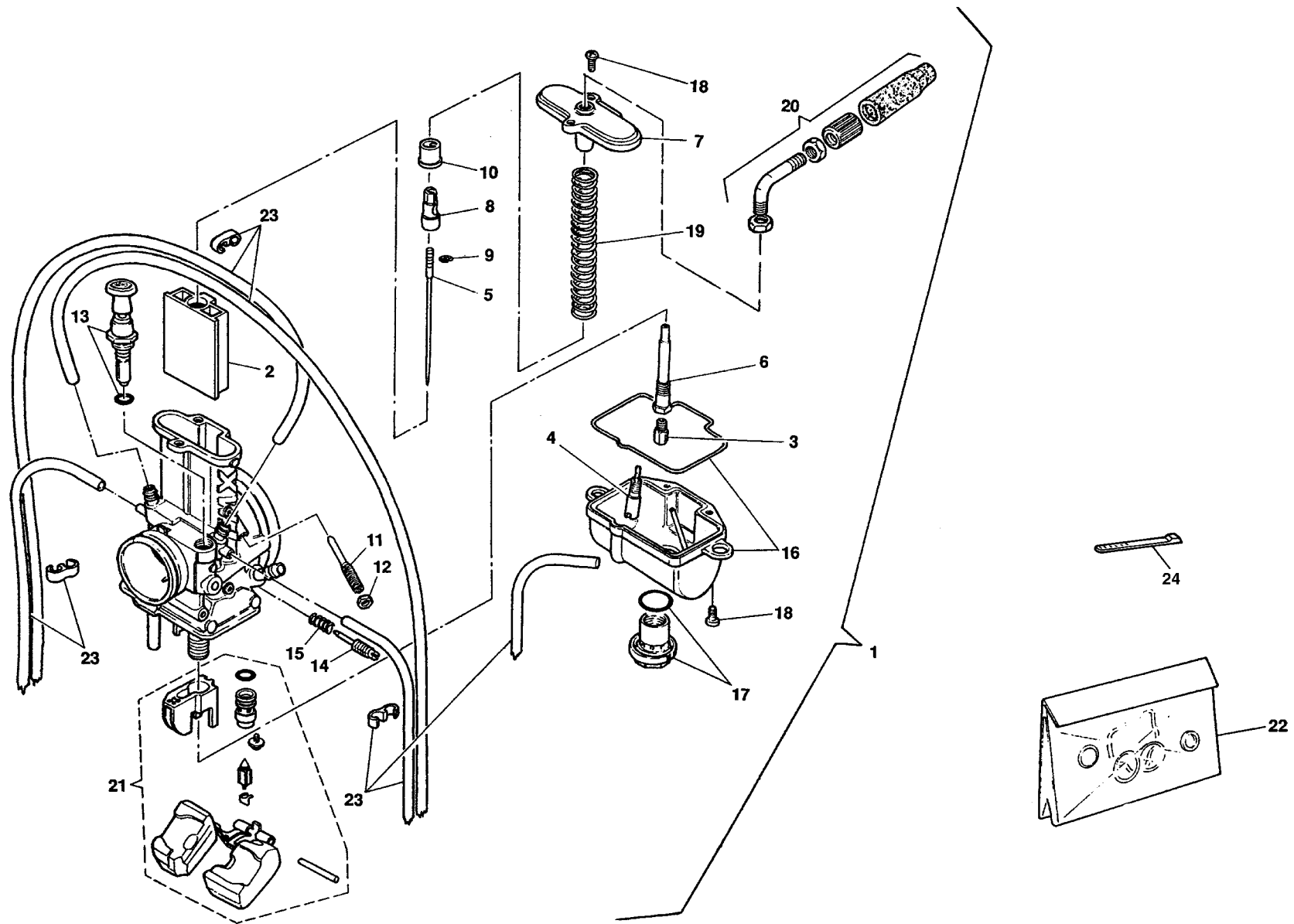

Note Notes Notas	Pos. No. N. Index Pos.	N. Cod. Code No. Nr. Code Code Nr N. Cod.	Q.tà Q.ty Q.te M.ge C.ad	DENOMINAZIONE	NAME	DESIGNATION	BESHREIBUNG	DENOMINACION	Validità Validity Validité Gültig Validez
	1	8000 86907	1	Assieme carburatore	Carburetor assy	Carburateur compl.	Vergaser kpl.	Carburador compl.	
	2	8000 86918	1	Valvola gas da (3.0)	Throttle valve (3.0)	Papillon de gaz (3.0)	Drosselklappe (3.0)	Válvula (3.0)	
DY	2	8D00 86918	1	Valvola gas da (4.0)	Throttle valve (4.0)	Papillon de gaz (4.0)	Drosselklappe (4.0)	Válvula (4.0)	
R	2	8A00 86918	1	Valvola gas da (2.5)	Throttle valve (2.5)	Papillon de gaz (2.5)	Drosselklappe (2.5)	Válvula (2.5)	
R	2	8B00 86918	1	Valvola gas da (3.5)	Throttle valve (3.5)	Papillon de gaz (3.5)	Drosselklappe (3.5)	Válvula (3.5)	
	3	8W00 72310	1	Getto max. (400)	Main jet (400)	Gicleur principal (400)	Hauptdüse (400)	Chiclé máximo (400)	
DR	3	8T00 72310	1	Getto max. (370)	Main jet (370)	Gicleur principal (370)	Hauptdüse (370)	Chiclé máximo (370)	
DR	3	8U00 72310	1	Getto max. (380)	Main jet (380)	Gicleur principal (380)	Hauptdüse (380)	Chiclé máximo (380)	
DR	3	8V00 72310	1	Getto max. (390)	Main jet (390)	Gicleur principal (390)	Hauptdüse (390)	Chiclé máximo (390)	
DR	3	8X00 72310	1	Getto max. (410)	Main jet (410)	Gicleur principal (410)	Hauptdüse (410)	Chiclé máximo (410)	
R	3	8Y00 72310	1	Getto max. (420)	Main jet (420)	Gicleur principal (420)	Hauptdüse (420)	Chiclé máximo (420)	
R	3	8Z00 72310	1	Getto max. (430)	Main jet (430)	Gicleur principal (430)	Hauptdüse (430)	Chiclé máximo (430)	
	4	8B00 A1804	1	Getto minimo (35)	Idle jet (35)	Gicleur minimum (35)	Leerlaufdüse (35)	Chiclé mínimo (35)	
DC	4	8B00 A1804	1	Getto minimo (35)	Idle jet (35)	Gicleur minimum (35)	Leerlaufdüse (35)	Chiclé mínimo (35)	
R	4	8000 A1804	1	Getto minimo (30)	Idle jet (30)	Gicleur minimum (30)	Leerlaufdüse (30)	Chiclé mínimo (30)	
DR	4	8L00 A1804	1	Getto minimo (40)	Idle jet (40)	Gicleur minimum (40)	Leerlaufdüse (40)	Chiclé mínimo (40)	
D	4	8M00 A1804	1	Getto minimo (45)	Idle jet (45)	Gicleur minimum (45)	Leerlaufdüse (45)	Chiclé mínimo (45)	
	5	8000 86920	1	Spillo conico (60-3a tacca)	Needle (60-3rd)	Pointeau conique (60-3ème)	Kon. Nadel (60-3.)	Pasador cónico (60-3°)	
D	5	8C00 86920	1	Spillo conico (58)	Needle (58)	Pointeau conique (58)	Kon. Nadel (58)	Pasador cónico (58)	
DR	5	8A00 86920	1	Spillo conico (59)	Needle (59)	Pointeau conique (59)	Kon. Nadel (59)	Pasador cónico (59)	
R	5	8B00 86920	1	Spillo conico (61)	Needle (61)	Pointeau conique (61)	Kon. Nadel (61)	Pasador cónico (61)	
	6	8000 86921	1	Polverizzatore	Fuel nozzle	Pulvérisateur	Einspritzdüse	Pulverizadør	
	7	8000 86932	1	Coperchio	Cover	Couvercle	Deckel	Tapa	
	8	8000 86978	1	Fermo spillo e molla	Retainer	Arrêt	Klammer	Pasadør	
	9	8000 72323	1	Anello SEEGER	SEEGER ring	Anneau SEEGER	Ring SEEGER	Anillo SEEGER	
	10	8000 86925	1	Guida molla	Spring seat	Siège ressort	Feder sitzring	Alojamiento resorte	
	11	8000 86926	1	Vite aria	Screw	Vis	Schraube	Tornillo	
	12	8000 86927	1	Dado	Nut	Ecrou	Mutter	Tuerca	
	13	8000 72327	1	Dispositivo avviamento	Starting device	Dispositif de démarrage	Startvorrichtung	Dispositivo puesta en marcha	
	14	8000 72328	1	Vite minimo	Screw	Vis	Schraube	Tornillo	
	15	8000 72329	1	Molla	Spring	Ressort	Feder	Resorte	
	16	8000 86928	1	Vaschetta	Chamber	Cuvette	Becken	Cubeta	
	17	8000 72331	1	Dado	Nut	Ecrou	Mutter	Tuerca	

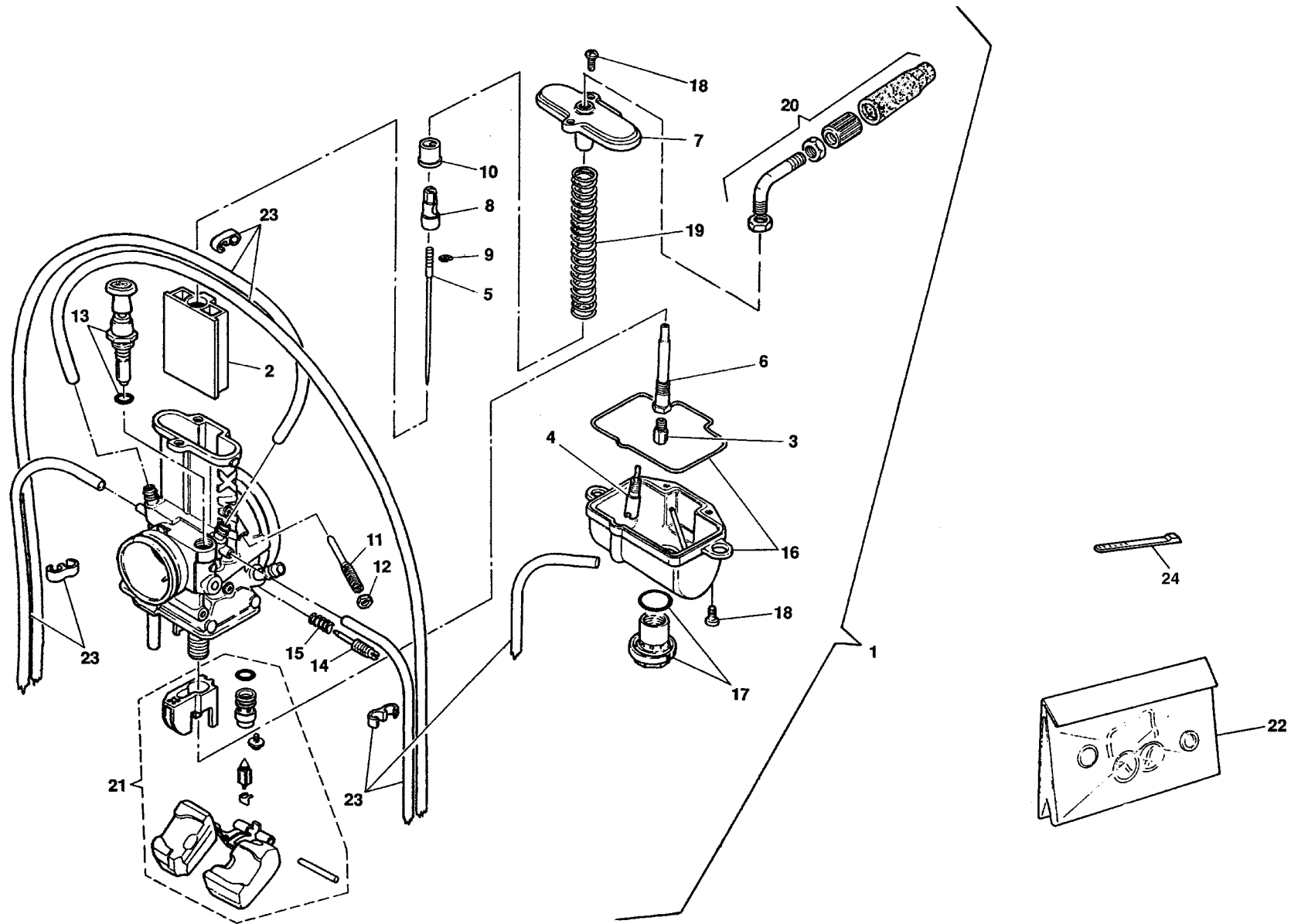

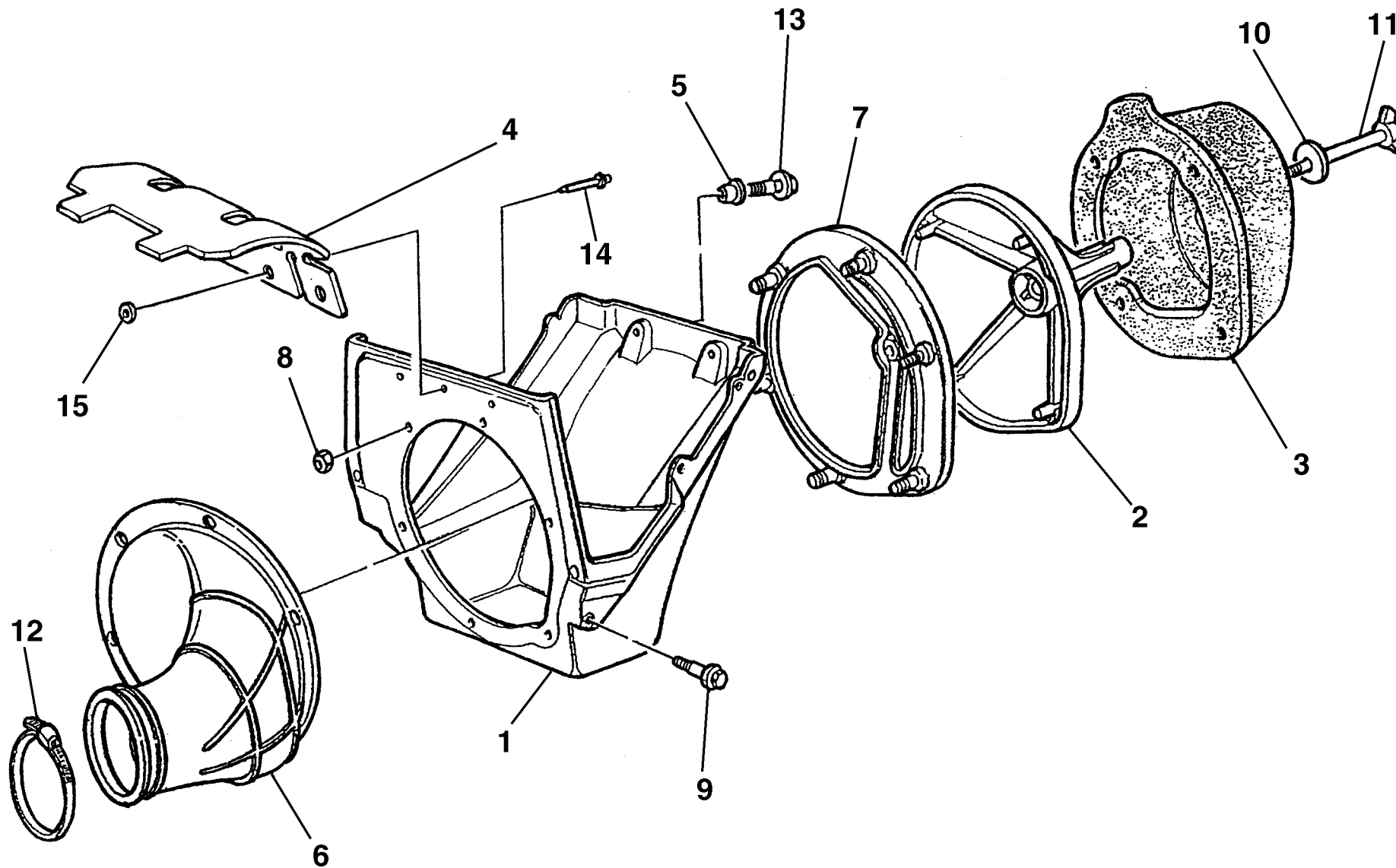

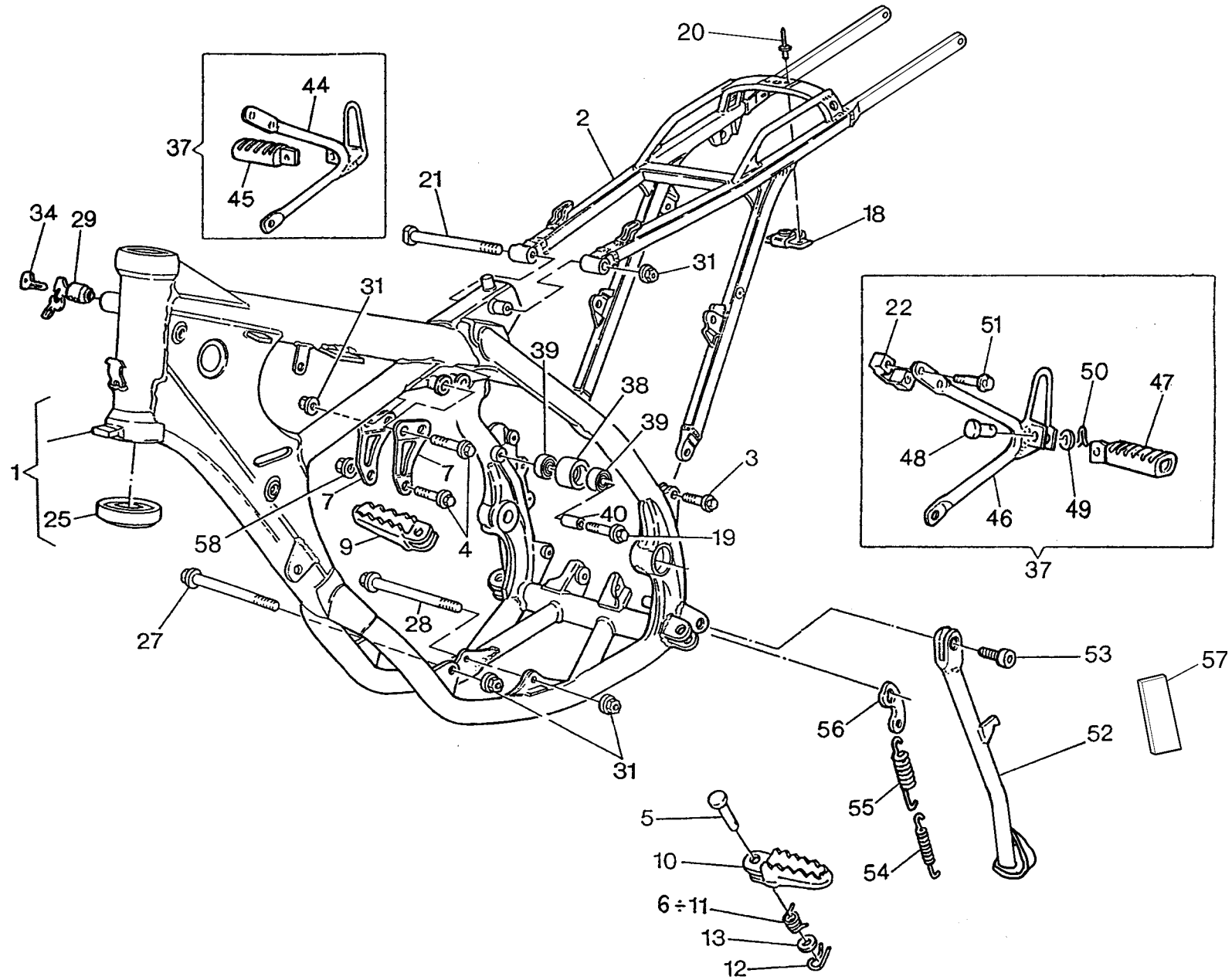

Note Notes Notas Marka Notas	Pos. No. N. Index Pos.	N. Cod. Code No. Nr. Code Code Nr N. Cod.	Q.tà Q.ty Q.te M.ge C.ad	DENOMINAZIONE	NAME	DESIGNATION	BESHREIBUNG	DENOMINACION	Validità Validity Validité Gültig Validez
W	1	8A00 97069	1	Parte anteriore completa	Frame front side assy	Chassis av. compl.	Rahmen kpl.	Cuadro anterior compl.	
C	1	8A00 97029	1	Parte anteriore completa	Frame front side assy	Chassis av. compl.	Rahmen kpl.	Cuadro anterior compl.	
U	1	8E00 97069	1	Parte anteriore completa	Frame front side assy	Chassis av. compl.	Rahmen kpl.	Cuadro anterior compl.	
	2	8000 A0350	1	Parte posteriore telaio	Rear frame side	Chassis arrière	Sattelbrücke	Cuadro posterior	
	3	8000 69056	2	Vite (M8x20 mm)	Screw (M8x20 mm)	Vis (M8x20 mm)	Schraube (M8x20 mm)	Tornillo (M8x20 mm)	
	4	8000 62795	2	Vite (M8x50 mm)	Screw (M8x50 mm)	Vis (M8x50 mm)	Schraube (M8x50 mm)	Tornillo (M8x50 mm)	
	4	8A00 62797	1	Vite (M10x50 mm)	Screw (M10x50 mm)	Vis (M10x50 mm)	Schraube (M10x50 mm)	Tornillo (M10x50 mm)	
	5	8000 73140	2	Perno	Pin	Goupille	Stift	Clavija	
	6	8000 96907	1	Molla Sx	L.H. spring	Ressort G.	Feder L.	Resorte lz.	
	7	8000 69434	2	Piastra fissaggio motore	Plate	Plaque	Platte	Placa	
	9	80A0 89953	1	Pedana destra	R.H. foot-rest	Repose-pieds D.	R. Fussraste	Pedal delnt. derech. compl.	
	10	80A0 89962	1	Pedana sinistra	L.H. foot-rest	Repose-pieds G.	L. Fussraste	Pedal delant. izrdo. compl.	
	11	8000 96908	1	Molla Dx	R.H. spring	Ressort D.	Feder R.	Resorte Der.	
	12	64N1 20068	2	Copiglia	Split pin	Goupille	Splint	Clavija	
	13	8A00 01815	2	Rosetta	Washer	Rondelle	Scheibe	Arandela	
	18	8000 69150	1	Piastrina	Plate	Plaquette	Plättchen	Placa	
	19	8000 62796	2	Vite (M8x40 mm)	Screw (M8x40 mm)	Vis (M8x40 mm)	Schraube (M8x40 mm)	Tornillo (M8x40 mm)	
	20	8000 33373	2	Rivetto	Rivet	Rivet	Niet	Remache	
	21	8000 69111	1	Vite (M8x130 mm)	Screw (M8x130 mm)	Vis (M8x130 mm)	Schraube (M8x130 mm)	Tornillo (M8x130 mm)	
XYD	22	8000 71091	2	Cavallotto	U-bolt	Cavalier	Bügelbolzen	Caballote	
W	25	1513 07001	2	Cuscinetto a rulli conici (ø25xø50x17,5 mm)	Bearing (ø25xø50x17,5 mm)	Roulement à rouleaux coniques (ø25xø50x17,5 mm)	Lager (ø25xø50x17,5 mm)	Cojinete de rodillos cónicos (ø25xø50x17,5 mm)	
C	25	8000 87243	2	Cuscinetto a rulli conici (ø29xø48x17,5 mm)	Bearing (ø29xø48x17,5 mm)	Roulement à rouleaux coniques (ø29xø48x17,5 mm)	Lager (ø29xø48x17,5 mm)	Cojinete de rodillos cónicos (ø29xø48x17,5 mm)	
	27	8000 73458	1	Perno ant. fiss. motore (M8x100 mm)	Pin (M8x100 mm)	Pivot (M8x100 mm)	Bolzen (M8x100 mm)	Perno (M8x100 mm)	
	28	8N00 73458	1	Perno inf. fiss. motore (M8x120 mm)	Pin (M8x120 mm)	Pivot (M8x120 mm)	Bolzen (M8x120 mm)	Perno (M8x120 mm)	
XY	29	8000 43391	1	Serratura antifurto completa	Anti-left lock assy	Serrure anti-vol compl.	Sicherheitsschloss kpl.	Cerradura compl.	
	31	8000 43928	6	Dado	Nut	Ecrou	Mutter	Tuerca	
XY	34	8000 35531	1	Chiave grezza	Raw key	Clef primitive	Schlüssel	Llave	
XYD	37	8A00 71086	1	Kit compl. poggiapiedi	Compl. footrest Kit	Appui-pied complet	kompl. Fussraster-Kit	Kit compl. apoyapiés	
	38	8000 59433	2	Rullo superiore	Roller	Aiguille	Rolle	Rodillo	

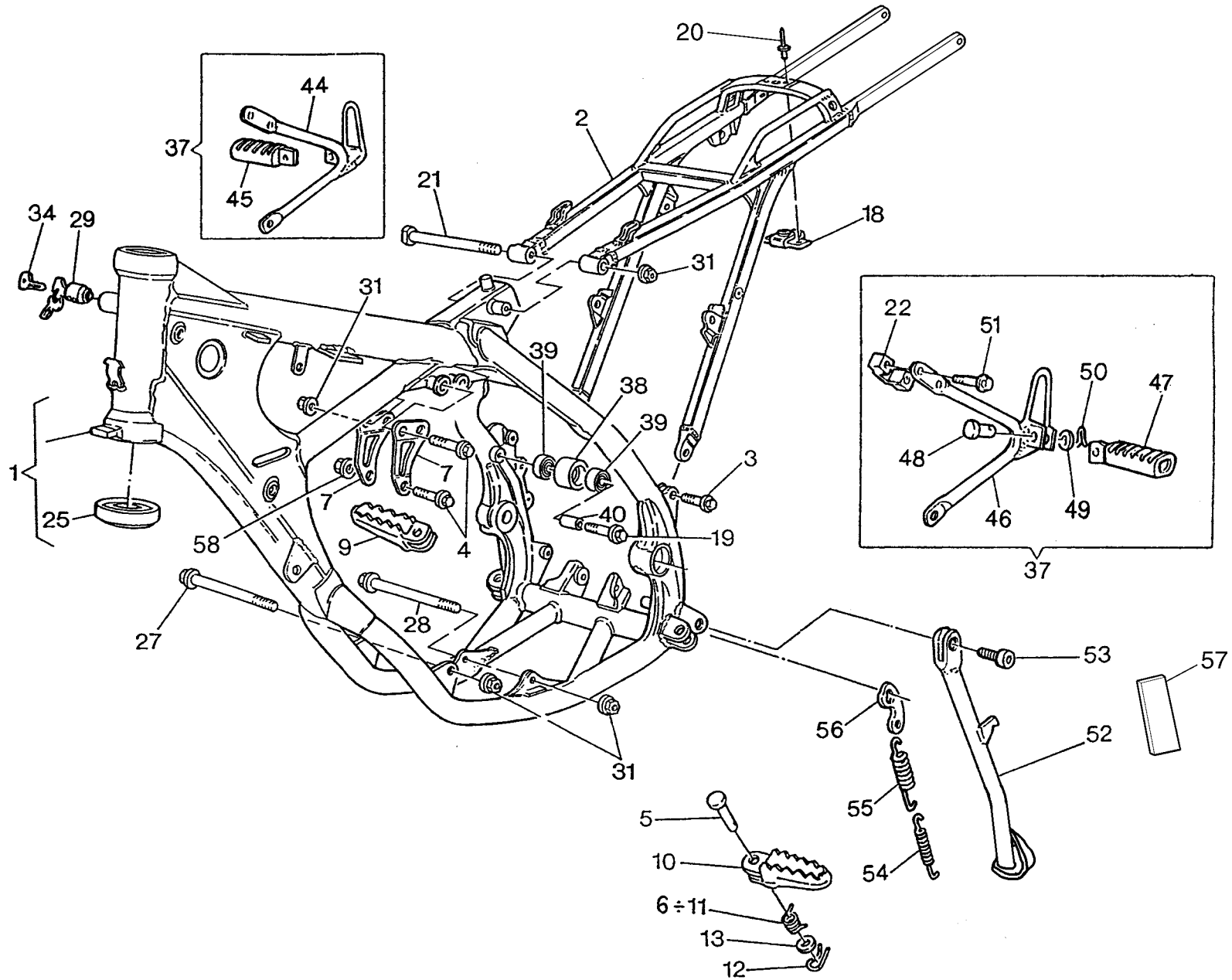

Note Notes Notas	Pos. No. N. Index Pos.	N. Cod. Code No. Nr. Code Code Nr N. Cod.	Q.tà Q.ty Q.te M.ge C.ad	DENOMINAZIONE	NAME	DESIGNATION	BESHREIBUNG	DENOMINACION	Validità Validity Validité Gültig Validez
	39	8000 63312	4	Cuscinetto (ø8xØ22x7 mm)	Bearing (ø8xØ22x7 mm)	Roulement (ø8xØ22x7 mm)	Kugellager (ø8xØ22x7 mm)	Cojinete (ø8xØ22x7 mm)	
	40	8000 59434	2	Distanziale	Spacer	Entretoise	Distanzstück	Separador	
XYD	44	8000 71088	1	Supporto Dx	R.H. support	Support D.	Halterung R.	Soporte der.	
XYD	45	8000 66652	1	Poggiapiedi passeggero Dx.	R.H. foot rest support	Support repose pied D.	R. Fussraster	Posapie der.	
XYD	46	8A00 71087	1	Supporto Sx.	L.H. support	Support G.	Halterung L.	Soporte izq.	
XYD	47	8000 66651	1	Poggiapiedi passeggero Sx.	L.H. foot rest support	Support repose pied G.	L. Fussraster	Posapie izq.	
XYD	48	8000 41459	2	Perno	Pin	Pivot	Bolzen	Perno	
XYD	49	62N1 15504	2	Rosetta	Washer	Rondelle	Scheibe	Arandela	
XYD	50	64N1 20048	2	Copiglia	Split pin	Goupille	Splint	Clavija	
XYD	51	8000 69056	2	Vite (M8x20 mm)	Screw (M8x20 mm)	Vis (M8x20 mm)	Schraube (M8x20 mm)	Tornillo (M8x20 mm)	
XYD	51	8000 62732	2	Vite (M8x25 mm)	Screw (M8x25 mm)	Vis (M8x25 mm)	Schraube (M8x25 mm)	Tornillo (M8x25 mm)	
Y	52	8000 98040	1	Gamba laterale	Side stand	Bequille laterale	Seitenständer	Horquilla lateral	
	53	8000 97976	1	Vite (M8x25 mm)	Screw (M8x25 mm)	Vis (M8x25 mm)	Schraube (M8x25 mm)	Tornillo (M8x25 mm)	
U	53	8A00 97977	1	Vite (M8x22,5 mm)	Screw (M8x22,5 mm)	Vis (M8x22,5 mm)	Schraube (M8x22,5 mm)	Tornillo (M8x22,5 mm)	
Y	54	8000 62676	1	Molla interna	Spring	Ressort	Feder	Resorte	
Y	55	8000 62675	1	Molla esterna	Spring	Ressort	Feder	Resorte	
Y	56	8000 84176	1	Piastrina	Plate	Plaque	Platte	Plaque	
	57	8A00 94356	1	Tampone	Pad	Tampon	Stopfen	Tampón	
	58	8000 42022	1	Dado	Nut	Ecrou	Mutter	Tuerca	

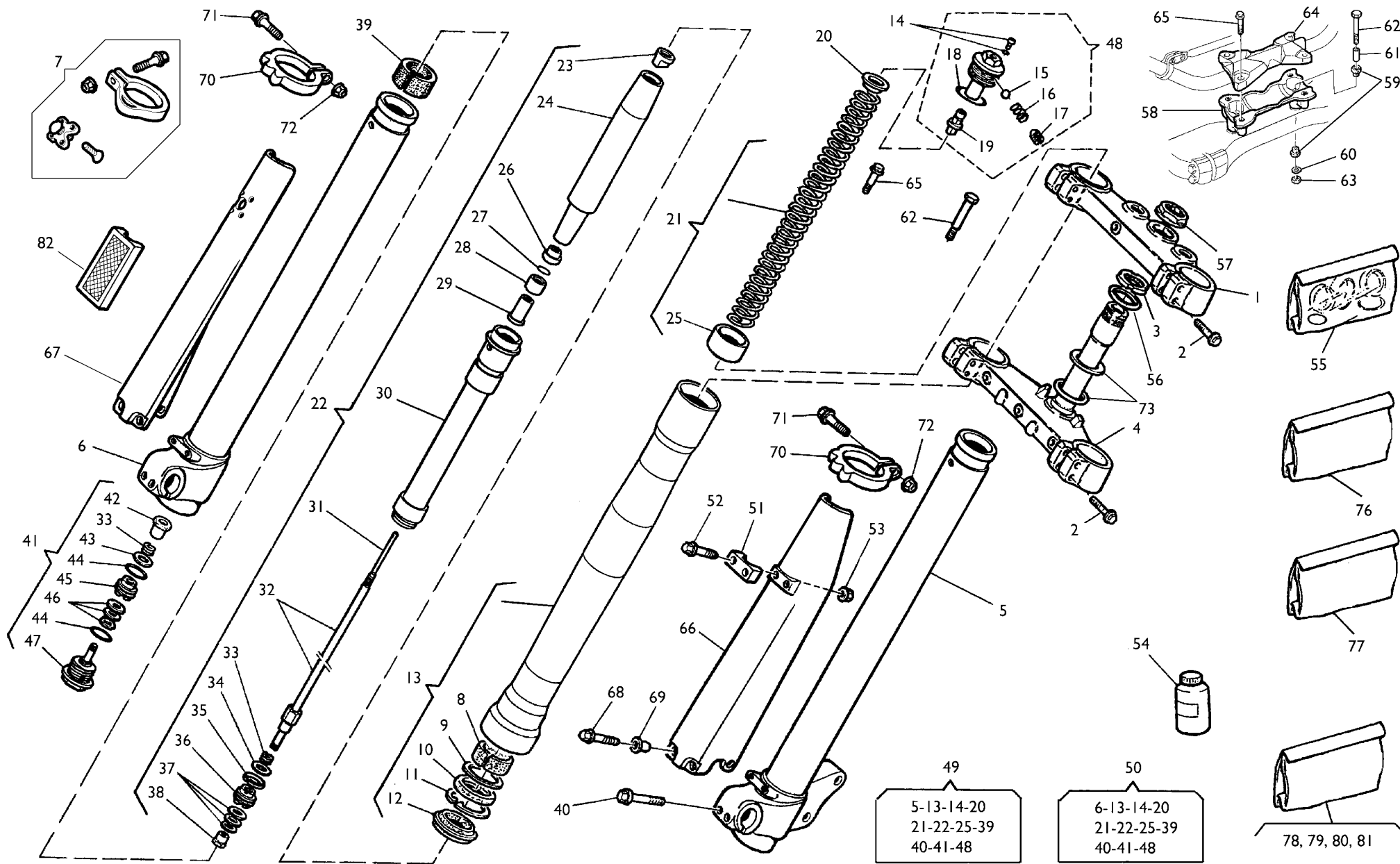

Note Notes Notas	Pos. No. Index Pos.	N. Cod. Code No. Nr. Code Code Nr N. Cod.	Q.tà Q.ty Q.te M.ge C.ad	DENOMINAZIONE	NAME	DESIGNATION	BESHREIBUNG	DENOMINACION	Validità Validity Validité Gültig Validez
W	1	8A00 96811	1	Testa di sterzo	Steering head	Tête direction	Lenkkopf	Cabezal de dirección	
C	1	8000 96811	1	Testa di sterzo	Steering head	Tête direction	Lenkkopf	Cabezal de dirección	
	2	8000 62796	8	Vite (M8x40 mm)	Screw (M8x40 mm)	Vis (M8x40 mm)	Schraube (M8x40 mm)	Tornillo (M8x40 mm)	
W	3	8000 83395	1	Ghiera registro cuscinetti	Ring nut	Embout	Nutmutter	Viol	
C	3	8A00 87717	1	Ghiera registro cuscinetti	Ring nut	Embout	Nutmutter	Viol	
W	4	8000 96897	1	Base di sterzo con perno	Steering crown with pin	Socle de direction avec pivot	Gabelbrücke mit Bolzen	Base de dirección con perno	
C	4	8000 96813	1	Base di sterzo con perno	Steering crown with pin	Socle de direction avec pivot	Gabelbrücke mit Bolzen	Base de dirección con perno	
	5	8000 98787	1	Stelo Sx. compl.	L.H. slider assy	Montant G. compl.	Bein, Kpl. L.	Deslizable izrda. compl.	
	6	8000 98786	1	Stelo Dx. compl.	R.H. slider assy	Montant D. compl.	Bein, Kpl. R.	Deslizable der. compl.	
C	7	8000 A3191	1	Kit gancio partenza	Kit starting hook	Kit crochet pour départ	Abfahrthacken	Gancho por salida	
N	8	(a), (b)	2	Bussola	Bushing	Douille	Buchse	Manguito	
N	9		2	Scodellino	Cup	Cuvette	Teller	Cubeta	
N	10	(a), (c)	2	Anello di tenuta	Seal ring	Bague de retenue	Dichtring	Anillo de retención	
N	11	(c)	2	Anello di fermo	Stop ring	Bague d'arrêt	Haltering	Anillo de retención	
N	12	(a), (c)	2	Raschiapolvere	Dust scraper	Racloir poudre	Pulverabschaber	Rascador de polvo	
	13	8000 91474	2	Portastelo completo	Pipe assy	Groupe tuyau compl.	Rohrgruppe Kpl	Grupo tubo compl.	
N	14		2	Vite	Screw	Vis	Schraube	Tornillo	
N	15		2	Sfera	Ball	Bille	Kugel	Esfera	
N	16		2	Molla per sfera	Spring	Ressort	Feder	Resorte	
N	17		2	Grano filettato	Dowel	Grain	Stift	Pasadòr	
N	18	(a)	2	Anello OR	O-Ring	Bague OR	O-Ring	Anillo OR	
	19	8000 91479	2	Gruppo registro	Adjuster set	Groupe reglage	Reglergruppe	Grupo regulaciòn	
	20	8000 77373	2	Scodellino	Cup	Cuvette	Teller	Cubeta	
W	21	8000 98791	1	Kit molla (k= 4,2 N/mm)	Spring (k= 4,2 N/mm)	Ressort (k= 4,2 N/mm)	Feder (k= 4,2 N/mm)	Resorte (k= 4,2 N/mm)	
C	21	8000 91610	1	Kit molla (k= 4,5 N/mm)	Spring (k= 4,5 N/mm)	Ressort (k= 4,5 N/mm)	Feder (k= 4,5 N/mm)	Resorte (k= 4,5 N/mm)	
W	22	8000 98552	2	Gruppo pompante compl.	Damping element compl.	Amortissement compl.	Schwingungsdämpfer Kpl.	Bombedora compl.	
C	22	8000 98792	2	Gruppo pompante compl.	Damping element compl.	Amortissement compl.	Schwingungsdämpfer Kpl.	Bombedora compl.	
N	23		2	Dado	Nut	Ecrou	Mutter	Tuerca	
N	24		2	Guidamolla	Spring guide	Guide ressort	Federführung	Guia resorte	
N	25		2	Tubetto	Pipe	Tuyau	Rohr	Tubo	
N	26		2	Dado	Nut	Ecrou	Mutter	Tuerca	
N	27		2	Anello SEEGER	SEEGER ring	Anneau SEEGER	SEEGER Ring	Anillo SEEGER	
N	28		2	Tampone di fondo	Pad	Tampon	Stopfen	Tampòn	

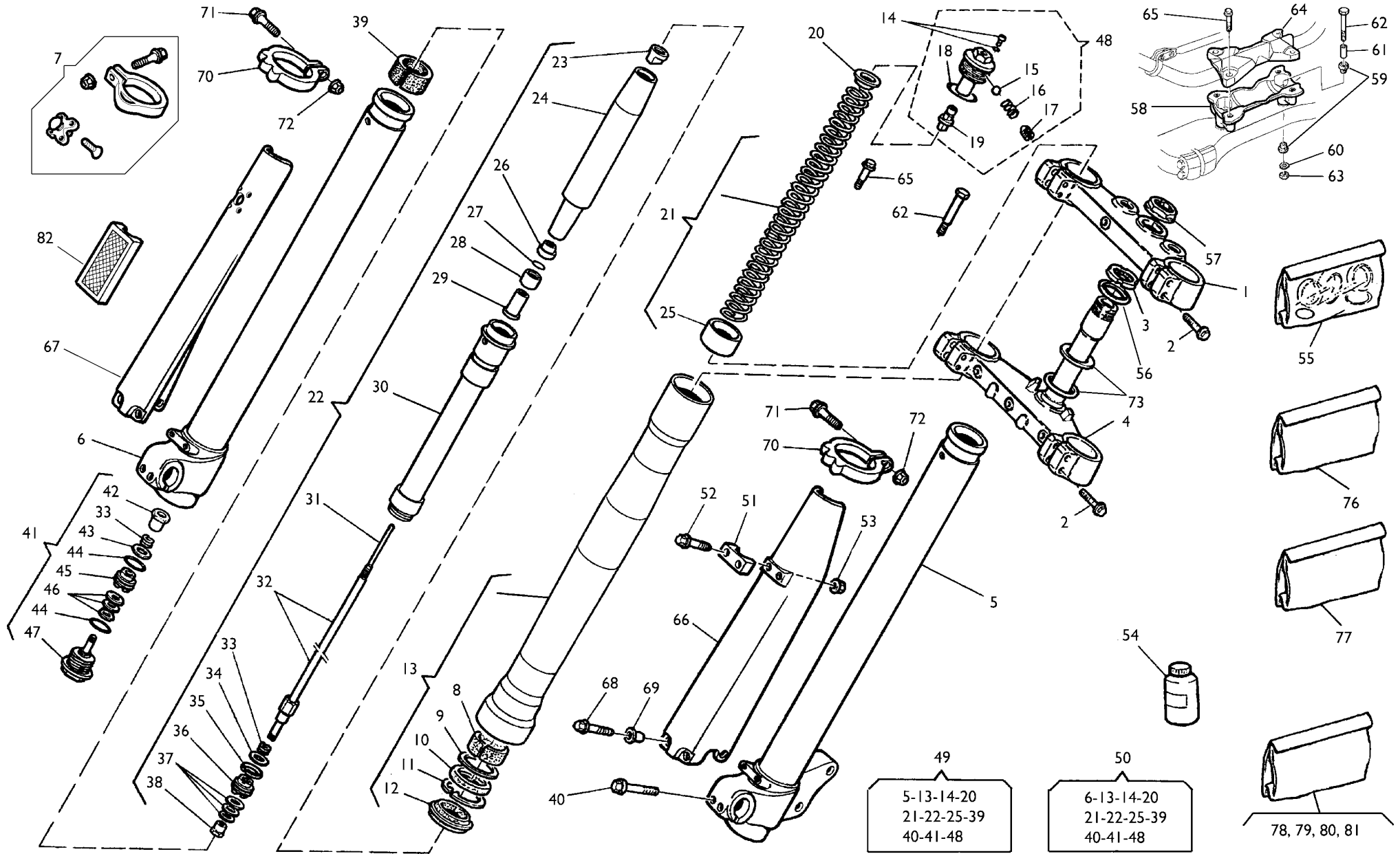

Note Notes Notas	Pos. No. Index Pos.	N. Cod. Code No. Nr. Code Code Nr N. Cod.	Q.tà Q.ty Q.te M.ge C.ad	DENOMINAZIONE	NAME	DESIGNATION	BESHREIBUNG	DENOMINACION	Validità Validity Validité Gültig Validez
N	29		2	Distanziale	Spacer	Entretoise	Distanzstück	Separadòr	
N	30		2	Custodia	Housung	Cage	Korb	Custodia	
N	31		2	Asta interna	Internal rod	Barre	Stange	Varilla	
N	32		2	Ass. asta	Rod assy	Barre compl.	Stange Kpl	Grupo varilla	
N	33		4	Molla	Spring	Ressort	Feder	Resorte	
N	34	(d)	2	Lamella	Plate	Lamelle	Plättchen	Laminilla	
N	35	(a)	2	Segmento	Circlip	Segment	Colbenring	Segmento	
N	36		2	Pistone estensione	R.H. piston	Piston D.	Kolbe R.	Pistón der.	
N	37	(d)	6	Lamella	Plate	Lamelle	Plättchen	Laminilla	
N	38		2	Dado	Nut	Ecrou	Mutter	Tueca	
N	39	(a), (b)	2	Bussola	Bushing	Douille	Buchse	Manguito	
	40	8000 62729	4	Vite (M6x25 mm)	Screw (M6x25 mm)	Vis (M6x25 mm)	Schraube (M6x25 mm)	Tornillo (M6x25 mm)	
W	41	8000 98806	2	Ass. valvola di fondo	Valve	Soupape	Ventil	Válvula	
C	41	8000 95260	2	Ass. valvola di fondo	Valve	Soupape	Ventil	Válvula	
N	42		2	Dado	Nut	Ecrou	Mutter	Tuerca	
N	43	(d)	2	Lamella	Plate	Lamelle	Plättchen	Laminilla	
N	44	(a)	2	Anello OR	O-Ring	Bague OR	O-Ring	Anillo OR	
N	45		2	Pistone compressione	Piston	Piston	Kolbe	Pistón	
N	46	(d)	6	Lamella	Plate	Lamelle	Plättchen	Laminilla	
N	47		2	Valvola	Valve	Soupape	Ventil	Valvula	
	48	8000 91480	2	Gruppo tappo	Plug assy	Groupe bouchon	Verschlussgruppe Kpl	Grupo tapón	
W	49	8A00 97149	1	Gamba Sx. compl.	L.H. fork leg assy	Fourche complete G.	Telegabel Kpl. L.	Horquilla izrda. compl.	
C	49	8000 97035	1	Gamba Sx. compl.	L.H. fork leg assy	Fourche complete G.	Telegabel Kpl. L.	Horquilla izrda. compl.	
W	50	8A00 97148	1	Gamba Dx. compl.	R.H. fork leg assy	Fourche complete D.	Telegabel Kpl. R.	Horquilla derech. compl.	
C	50	8000 97034	1	Gamba Dx. compl.	R.H. fork leg assy	Fourche complete D.	Telegabel Kpl. R.	Horquilla derech. compl.	
	51	8000 A0633	1	Piastrina	Plate	Plaquette	Plättchen	Placa	
	52	8A00 67997	2	Vite	Screw	Vis	Schraube	Tornillo	
	53	8000 61355	2	Dado	Nut	Ecrou	Mutter	Tueca	
R	54	8000 80260	1	Olio forcella	Front fork oil	Huile fourche avant	Öl für die Vordergabel	Aceite horquilladelantera	
	55	8000 91519	1	Gruppo guarnizioni	Gasket set	Groupe garnitures	Dichtungsatz	Grupo juntas	
W	56	8A00 65503	2	Rosetta piana	Washer	Rondelle	Scheibe	Arandela	
C	56	8000 87736	1	Rosetta piana	Washer	Rondelle	Scheibe	Arandela	
W	57	8000 69315	1	Dado	Nut	Ecrou	Mutter	Tuerca	

Note Notes Markes Notas	Pos. No. N. Index Pos.	N. Cod. Code No. Nr. Code Code Nr N. Cod.	Q.tà Q.ty Q.te M.ge C.ad	DENOMINAZIONE	NAME	DESIGNATION	BESHREIBUNG	DENOMINACION	Validità Validity Validité Gültig Validez
C	57	8A00 69315	1	Dado	Nut	Ecrou	Mutter	Tuerca	
	58	8000 98237	1	Mozzetto inferiore	Hub	Moyeau	Radnabe	Cbo	
	59	8000 60233	4	Gommino	Rubber pad	Pièce caoutchouc	Gummstück	Junta de goma	
	60	8000 60234	2	Rosetta piana	Washer	Rondelle	Scheibe	Arandela	
	61	8000 53155	2	Distanziale	Spacer	Entretoise	Distanzstück	Separador	
	62	60N1 01219	2	Vite (M10x65 mm)	Screw(M10x65 mm)	Vis(M10x65 mm)	Schraube(M10x65 mm)	Tornillo(M10x65 mm)	
	63	8000 61314	2	Dado	Nut	Ecrou	Mutter	Tuerca	
	64	8000 98118	2	Mozzetto superiore	Hub	Moyeau	Radnabe	Cubo	
	65	8C00 69056	4	Vite (M8x30 mm)	Screw (M8x30 mm)	Vis (M8x30 mm)	Schraube (M8x30 mm)	Tornillo (M8x30 mm)	
	66	80G0 69337	1	Protezione steli Sx.	Guard L.H.	Protection D.	Schutz L.	Protección izq.	
	67	80G0 69338	1	Protezione steli Dx.	Guard R.H.	Protection G.	Schutz R.	Protección der.	
	68	8000 67997	6	Vite	Screw	Vis	Schraube	Tornillo	
	69	8000 69282	6	Bussola	Bush	Douille	Buchse	Manguito	
	70	8000 93283	2	Anello	Ring	Bague	Ring	Anilo	
	71	8B00 66525	2	Vite	Screw	Vis	Schraube	Tornillo	
	72	8000 56443	2	Dado	Nut	Ecrou	Mutter	Tuerca	
C	73	8000 87745	2	Guarnizione di tenuta	Gasket	Garniture	Dichtung	Guarnición	
	76	8000 97750	1	Kit boccole	Bush kit	Kit douille	Buchsekit	Kit manguito	
	77	8000 97749	1	Kit anelli di tenuta	Seal ring kit	Kit bague de retenue	Dichtringkit	Kit anillo de retención	
	78	8000 98782	1	Kit lamelle (0,1 mm)	Plate kit (0,1 mm)	Kit lamelle (0,1 mm)	Plättchenkit (0,1 mm)	Kit Laminilla (0,1 mm)	
	79	8000 98783	1	Kit lamelle (0,2 mm)	Plate kit (0,2 mm)	Kit lamelle (0,2 mm)	Plättchenkit (0,2 mm)	Kit Laminilla (0,2 mm)	
	80	8000 98784	1	Kit lamelle (0,3 mm)	Plate kit (0,3 mm)	Kit lamelle (0,3 mm)	Plättchenkit (0,3 mm)	Kit Laminilla (0,3 mm)	
	81	8000 98785	1	Kit lamelle (0,4 mm)	Plate kit (0,4 mm)	Kit lamelle (0,4 mm)	Plättchenkit (0,4 mm)	Kit Laminilla (0,4 mm)	
	82	80B0 73832	2	Catadiottro (AUS, CDN)	Reflector (AUS, CDN)	Catadioptrique (AUS, CDN)	Rückstrahler (AUS, CDN)	Catafaros (AUS, CDN)	
a				Forniti anche in gruppo pos. 55	Supplied in bag ref. N° 55	Son fournies en unités pos. 55	Sind im Umschlag Bez. Nr 55	Provisto en grupo pos. 55	
b				Forniti anche in gruppo pos. 76	Supplied in bag ref. N° 76	Son fournies en unités pos. 76	Sind im Umschlag Bez. Nr 76	Provisto en grupo pos. 76	
c				Forniti anche in gruppo pos. 77	Supplied in bag ref. N° 77	Son fournies en unités pos. 77	Sind im Umschlag Bez. Nr 77	Provisto en grupo pos. 77	
d				Forniti anche in gruppo pos. 78, 79, 80, 81	Supplied in bag ref. N° 78, 79, 80, 81	Son fournies en unités pos. 78, 79, 80, 81	Sind im Umschlag Bez. Nr 78, 79, 80, 81	Provisto en grupo pos. 78, 79, 80, 81	

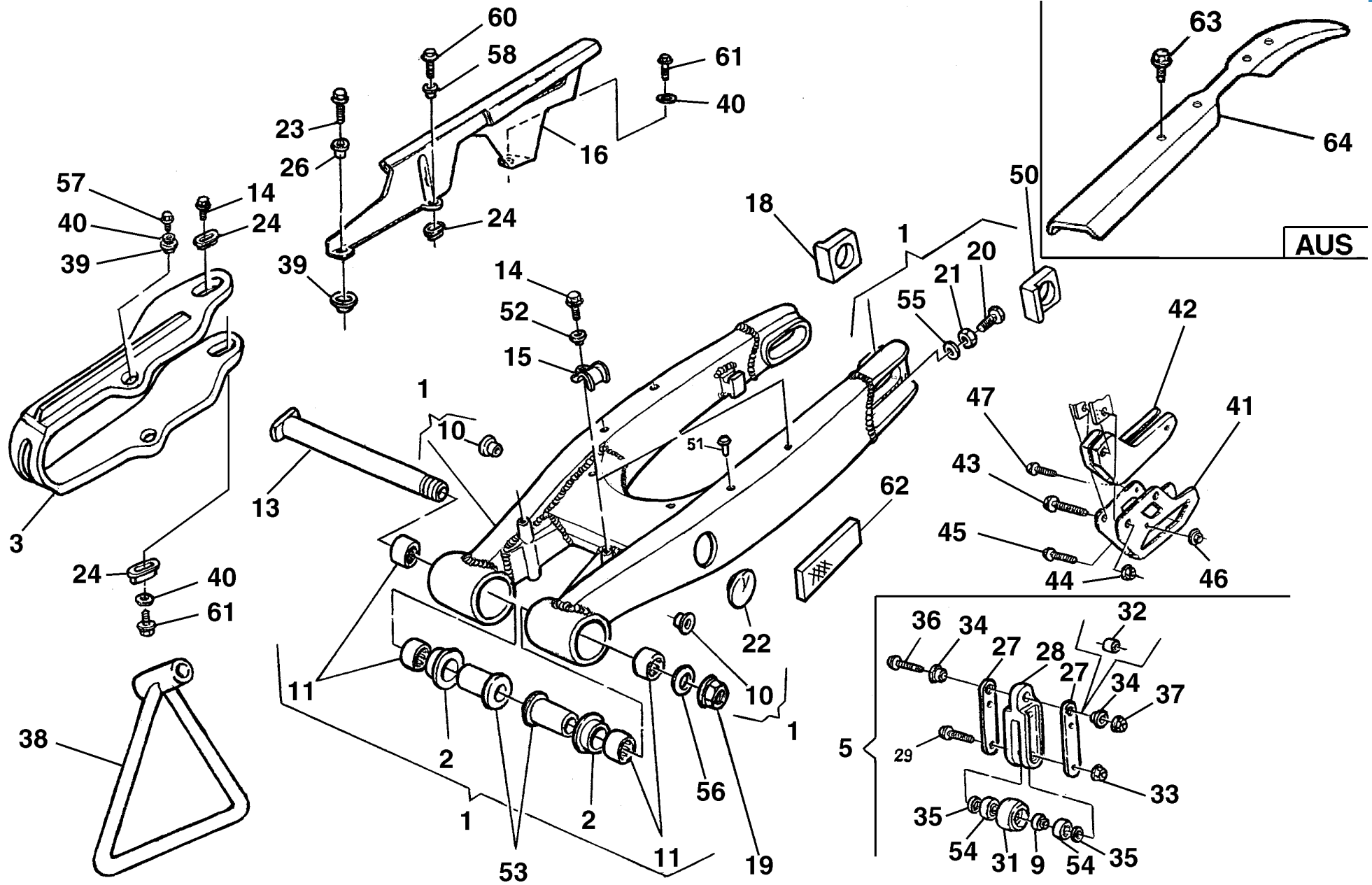

Note Notes Notas	Pos. No. Index Pos.	N. Cod. Code No. Nr. Code Code Nr N. Cod.	Q.tà Q.ty Q.te M.ge C.ad	DENOMINAZIONE	NAME	DESIGNATION	BESHREIBUNG	DENOMINACION	Validità Validity Validité Gültig Validez
	1	8000 97036	1	Forcellone completo	Swing arm assy.	Fourche complete	Gabel, Kpl.	Horquilla compl.	
	2	8000 71622	4	Bussola	Bushing	Douille	Buchse	Manguito	
	3	8000 96960	1	Pattino catena	Chain slider	Glissière	Gleitbahn	Plato catena	
Y	5	8000 72873	1	Ass. guidacatena	Chain guide	Guide chaine	Kettenführung	Guja catena	
Y	9	8000 65412	1	Distanziale	Spacer	Entretoise	Distanzstück	Separador	
	10	8000 87810	1	Bussola Sp.16 mm (lato disco)	R.H. bushing (th.16 mm)	Douille D. (èpaisseur 16 mm)	Buchse R. (Dicken 16 mm)	Manguito der. (esp.16 mm)	
	10	8A00 87810	1	Bussola Sp.13 mm (lato corona)	L.H. bushing (th.13 mm)	Douille G. (èpaisseur 13 mm)	Buchse L. (Dicken 13 mm)	Manguito iz. (esp.13 mm)	
	11	8000 76283	4	Gabbia a rullini (ø22xø28x18 mm)	Needle cage (ø22xø28x18 mm)	Cage à aiguilles (ø22xø28x18 mm)	Nadelkaefig (ø22xø28x18 mm)	Jaula de agujas del cojinete (ø22xø28x18 mm)	
	13	8000 71620	1	Perno forcellone	Fork pin	Pivot fourche	Gabelbolzen	Perno horquilla	
	14	8000 20536	1	Vite posteriore (Ø4,8x13 mm)	Rear screw (Ø4,8x13 mm)	Vis arriere(Ø4,8x13 mm)	Hinterschraube (Ø4,8x13 mm)	Tornillo trasero (Ø4,8x13 mm)	
	14	8000 67997	1	Vite anteriore (M5x12 mm)	Front screw (M5x12 mm)	Vis avant (M5x12 mm)	Vorderschraube (M5x12 mm)	Tornillo del. (M5x12 mm)	
	15	80A0 73456	2	Guidacavo	Cable guide	Guide câble	Kabelführung	Guía-cable	
XY	16	80A0 73426	1	Copricatena	Chain guard	Carter de chaine	Kettenkasten	Cubre-cadena	
	18	8000 96944	2	Tendicatena DX	Chain adjuster R.	Tendeur de chaine D.	Kettenspanner R.	Tensor de cadena D.	
	19	8000 71623	1	Dado	Nut	Ecrou	Mutter	.Tuerca	
	20	8C00 61121	2	Vite	Screw	Vis	Schraube	Tornillo	
	21	8000 17810	2	Dado	Nut	Ecrou	Mutter	Tuerca	
	22	80A0 74388	2	Tappo	Plug	Bouchon	Verschluss	Tapón	
XY	23	8A00 67997	1	Vite (M5x16 mm)	Screw (M5x16 mm)	Vis (M5x16 mm)	Schraube (M5x16 mm)	Tornillo (M5x16 mm)	
	24	8000 59289	3	Scodellino	Cup	Cuvette	Teller	Cubeta	
XY	26	8A00 69282	2	Bussola	Bushing	Douille	Buchse	Manguito	
Y	27	8000 72875	2	Piastra d'attacco	Plate	Plaque	Platte	Placa	
Y	28	8000 72874	1	Guidacatena	Chain guide	Guide-chaine	Kettenführung	Guía-cadena	
Y	29	8000 62731	2	Vite (M6x45 mm)	Screw (M6x45 mm)	Vis (M6x45 mm)	Schraube (M6x45 mm)	Tornillo (M6x45 mm)	
Y	31	8000 65411	1	Rullo	Roller	Aiguille	Rolle	Rodillo	
Y	32	1515 50601	1	Bussola	Bushing	Douille	Buchse	Manguito	
Y	33	8000 44240	2	Dado	Nut	Ecrou	Mutter	Tuerca	
Y	34	8A00 66661	2	Bussola	Bushing	Douille	Buchse	Manguito	
Y	35	8000 45495	2	Boccola di spallamento	Washer	Rondelle	Scheibe	Arandela	
Y	36	8000 62795	1	Vite	Screw	Vis	Schraube	Tornillo	
Y	37	8000 43928	1	Dado	Nut	Ecrou	Mutter	Tuerca	
CD	38	8000 74016	1	Gamba laterale	Side stand	Bequille lat.	Seitenstander	Horquilla lateral	

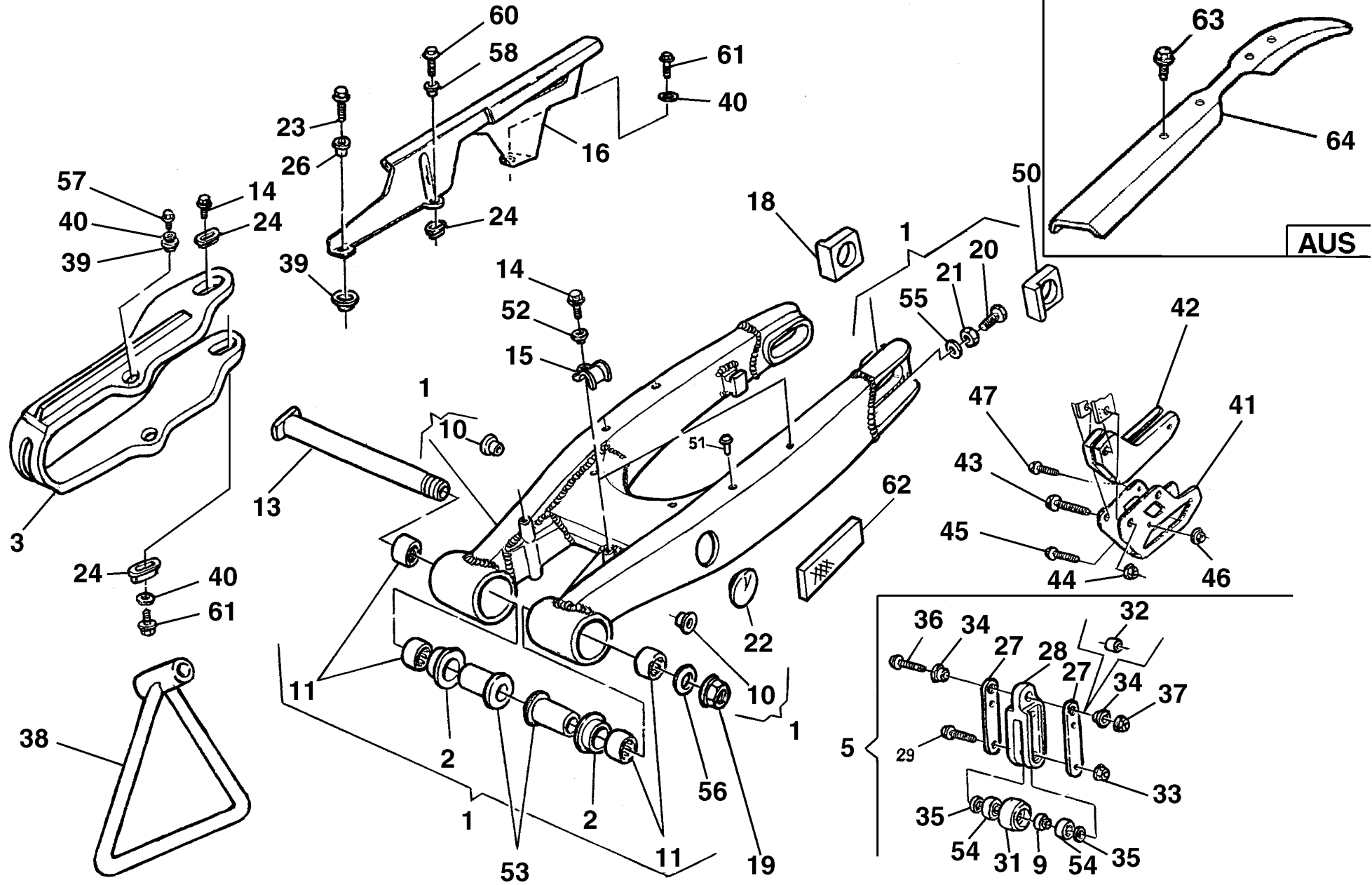

Note Notes Notas	Pos. No. Index Pos.	N. Cod. Code No. Nr. Code Code Nr N. Cod.	Q.tà Q.ty Q.te M.ge C.ad	DENOMINAZIONE	NAME	DESIGNATION	BESHREIBUNG	DENOMINACION	Validità Validity Validité Gültig Validez
	39	8000 75166	4	Scodellino	Cup	Cuvette	Teller	Cubeta	
	40	8000 36137	3	Rosetta piana	Washer	Rondelle	Scheibe	Arandela	
CU	41	8000 72869	1	Staffa	Bracket	Entier	Buegel	Brida	
CU	42	8000 72868	1	Guidacatena	Chain guide	Guidechaîne	Kettenführung	Guiacadena	
CU	43	8A00 62795	1	Vite (M8x50 mm)	Screw (M8x50 mm)	Vis (M8x50 mm)	Schraube (M8x50 mm)	Tornillo (M8x50 mm)	
CU	44	8000 43928	1	Dado	Nut	Ecrou	Mutter	Tuerca	
CU	45	8000 62731	1	Vite (M6x45 mm)	Screw (M6x45 mm)	Vis (M6x45 mm)	Schraube (M6x45 mm)	Tornillo (M6x45 mm)	
CU	46	8000 44240	1	Dado	Nut	Ecrou	Mutter	Tuerca	
CU	47	8000 62725	1	Vite (M6x10 mm)	Screw (M6x10 mm)	Vis (M6x10 mm)	Schraube (M6x10 mm)	Tornillo (M6x10 mm)	
	50	8000 96941	1	Tendicatena SX	Chain adjuster L.	Tendeur de chaine G.	Ketterspanne L.	Tensor de cadena I.	
	51	8000 75160	4	Rivetto	Rivet	Rivet	Niet	Remache	
	52	8000 69282	2	Bussola	Bushing	Douille	Buchse	Manguito	
	53	8000 71621	2	Bussola	Bushing	Douille	Buchse	Manguito	
Y	54	8000 63312	2	Cuscinetto (ø8xØ22x7 mm)	Bearing (ø8xØ22x7 mm)	Roulement (ø8xØ22x7 mm)	Lager (ø8xØ22x7 mm)	Cojinete (ø8xØ22x7 mm)	
	55	8000 08536	2	Rosetta piana	Washer	Rondelle	Scheibe	Arandela	
	56	8000 32388	1	Rosetta	Washer	Rondelle	Scheibe	Arandela	
	57	8000 67997	1	Vite	Screw	Vis	Schraube	Tornillo	
	58	8000 97025	1	Bussola	Bushing	Douille	Buchse	Manguito	
	60	60N1 01059	1	Vite (M5x35 mm)	Screw (M5x35 mm)	Vis (M5x35 mm)	Schraube (M5x35 mm)	Tornillo (M5x35 mm)	
	61	8000 20536	3	Vite (Ø4,8x13 mm)	Screw (Ø4,8x13 mm)	Vis (Ø4,8x13 mm)	Schraube (Ø4,8x13 mm)	Tornillo (Ø4,8x13 mm)	
	62	8000 73832	2	Catadiottro (CDN)	Reflector (CDN)	Catadioptrique (CDN)	Rückstrahler (CDN)	Catafaros (CDN)	
	63	8000 81628	4	Vite (AUS)	Screw (AUS)	Vis (AUS)	Schraube (AUS)	Tornillo (AUS)	
	64	8000 A2352	1	Prolunga (AUS)	Guard(AUS)	Carter (AUS)	Kasten (AUS)	Protección (AUS)	

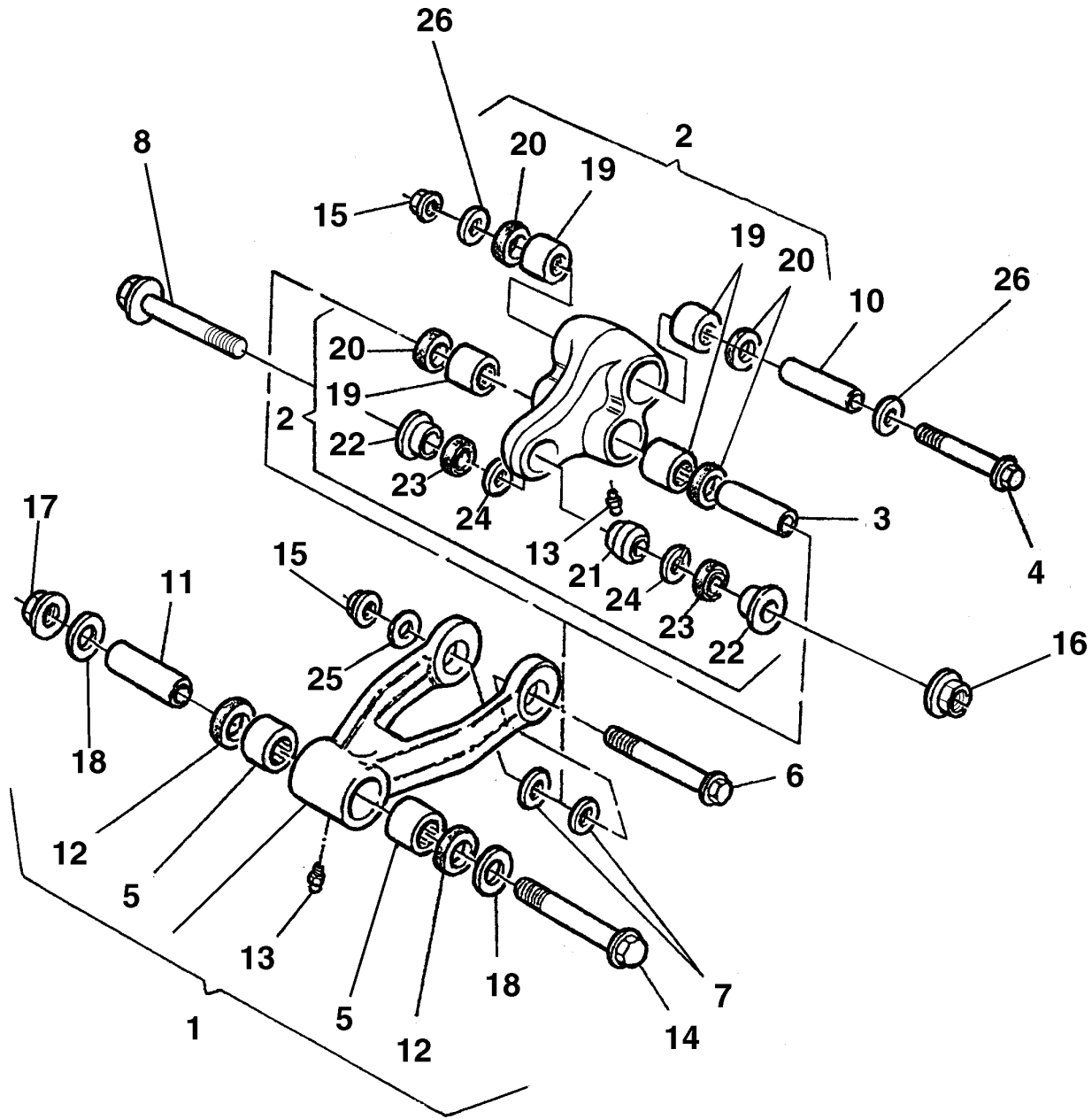

Note Notes Notas	Pos. No. Index Pos.	N. Cod. Code No. Nr. Code Code Nr N. Cod.	Q.tà Q.ty Q.te M.ge C.ad	DENOMINAZIONE	NAME	DESIGNATION	BESHREIBUNG	DENOMINACION	Validità Validity Validité Gültig Validez
	1	8000 96922	1	Tirante completo	Tie rod	Tirant	Spannstange	Tirante	
	2	8000 96923	1	Assieme bilanciare	Rocking lever assy	Balancier compl.	Schwinge Kpl.	Balancines compl.	
	3	8000 86176	1	Spinotto	Gudgeon	Axe	Bolzen	Perno	
	4	8A00 86138	1	Perno (M12x106 mm)	Pin (M12x106 mm)	Pivot (M12x106 mm)	Bolzen (M12x106 mm)	Perno (M12x106 mm)	
	5	8000 86136	2	Boccola a rullini (ø22xø28x16 mm)	Rollenbush (ø22xø28x16 mm)	Douille rouleaux (ø22xø28x16 mm)	Rollerbuchse (ø22xø28x16 mm)	Casquillo (ø22xø28x16 mm)	
	6	8000 93124	1	Perno (M12x103 mm)	Pin (M12x103 mm)	Pivot (M12x103 mm)	Bolzen (M12x103 mm)	Perno (M12x103 mm)	
	7	8000 86177	2	Bussola	Bushing	Douille	Buchse	Manguito	
	8	8D00 62797	1	Perno (M10x47 mm)	Pin (M10x47 mm)	Pivot (M10x47 mm)	Bolzen (M10x47 mm)	Perno (M10x47 mm)	
	10	8000 86176	1	Spinotto	Gudgeon	Axe	Bolzen	Perno	
	11	8A00 86176	1	Spinotto	Gudgeon	Axe	Bolzen	Perno	
	12	8000 38521	2	Anello di tenuta (ø22xø28x4 mm)	Seal ring (ø22xø28x4 mm)	Bague d'étanchéité (ø22xø28x4 mm)	Dichtungsring (ø22xø28x4 mm)	Anillo de retención (ø22xø28x4 mm)	
	13	8000 01412	2	Ingrassatore	Lubricator	Graisser	Schmierbüchse	Lubricador	
	14	8C00 86138	1	Perno (M12x81 mm)	Pin (M12x81 mm)	Pivot (M12x81 mm)	Bolzen (M12x81 mm)	Perno (M12x81 mm)	
	15	8000 42023	2	Dado	Nut	Ecrou	Mutter	Tuerca	
	16	8000 42022	1	Dado	Nut	Ecrou	Mutter	Tuerca	
	17	8000 42023	1	Dado	Nut	Ecrou	Mutter	Tuerca	
	18	8000 86140	1	Rosetta per dado	Ring	Bague	Ring	Anillo	
	19	8A00 86136	4	Boccola a rullini (ø22xø28x20 mm)	Rollenbush (ø22xø28x20 mm)	Douille rouleaux (ø22xø28x20 mm)	Rollerbuchse (ø22xø28x20 mm)	Casquillo (ø22xø28x20 mm)	
	20	8000 86137	4	Anello di tenuta (ø26xø34x4 mm)	Seal ring (ø26xø34x4 mm)	Bague d'étanchéité (ø26xø34x4 mm)	Dichtungsring (ø26xø34x4 mm)	Anillo de retención (ø26xø34x4 mm)	
	21	8000 72168	1	Snodo a sfera	Ball joint	Joint a rotule	Kugelgelenk	Articulacion esferica	
	22	1511 33302	2	Bussola	Bushing	Douille	Buchse	Manguito	
	23	8000 38767	2	Anello di tenuta (ø26xø15x4mm)	Seal ring (ø26xø15x4mm)	Bague d'étanchéité (ø26xø15x4mm)	Dichtungsring (ø26xø15x4mm)	Anillo de retención (ø26xø15x4mm)	
	24	8000 90561	2	Anello elastico	Snap ring	Bague d'arret	Haltering	Anillo elástico	
	26	8000 86177	2	Distanziale	Spacer	Entretoise	Distanzstück	Separadør	

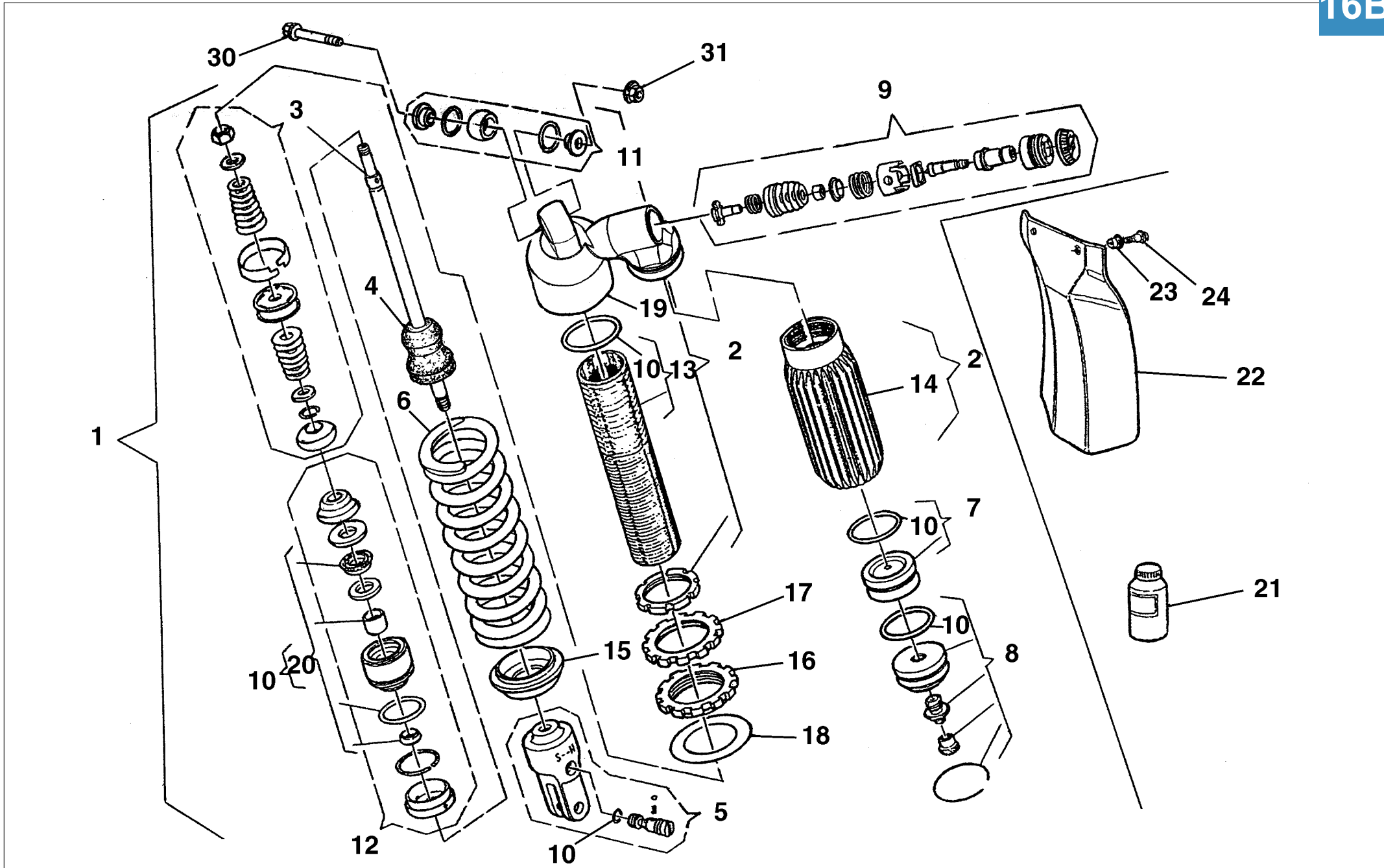

Note Notes Notas	Pos. No. N. Index Pos.	N. Cod. Code No. Nr. Code Code Nr N. Cod.	Q.tà Q.ty Q.te M.ge C.ad	DENOMINAZIONE	NAME	DESIGNATION	BESHREIBUNG	DENOMINACION	Validità Validity Validité Gültig Validez
W	1	8000 97152	1	Ammortizzatore completo	Shock-absorber assy.	Ammortisseur compl.	Stossdampfer Kpl.	Amortigüador compl.	
C	1	8000 97038	1	Ammortizzatore completo	Shock-absorber assy.	Ammortisseur compl.	Stossdampfer Kpl.	Amortigüador compl.	
	2	8000 98500	1	Gruppo corpo	Damper case assy	Groupe corps ammortisseur	Stossdämpferkörper Kpl.	Corpo amortigüador compl.	
W	3	8000 98507	1	Gruppo stelo	Rod assy	Groupe tige	Pumpenstückgruppe	Grupo espiga	
C	3	8000 98511	1	Gruppo stelo	Rod assy	Groupe tige	Pumpenstückgruppe	Grupo espiga	
	4	8000 91238	1	Tampone	Pad	Tampon	Stopfen	Tampòn	
	5	8000 98489	1	Gruppo forcella	Fork assy	Groupe fourche	Gabelgruppe Kpl.	Grupo horquilla	
C	6	8000 98569	1	Molla (k=5,2 Kg/mm)	Spring (k=5,2 Kg/mm)	Ressort (k=5,2 Kg/mm)	Feder (k=5,2 Kg/mm)	Resorte (k=5,2 Kg/mm)	
W	6	8000 98570	1	Molla (k=5,4 Kg/mm)	Spring (k=5,4 Kg/mm)	Ressort (k=5,4 Kg/mm)	Feder (k=5,4 Kg/mm)	Resorte (k=5,4 Kg/mm)	
	7	8000 98490	1	Diaframma	Diaphragm	Diaphragme	Biegeplatte	Diafragma	
	8	8000 98491	1	Gruppo serbatoio	Tank assy	Groupe reservoir	Tankgruppe Kpl.	Grupo deposito compl.	
	9	8000 98492	1	Gruppo regolazione	Adjuster set	Groupe réglage	Reglergruppe Kpl.	Grupo regulacion	
	10	8000 98493	1	Gruppo guarnizioni	Gasket set	Groupe garnitures	Dichtungssatz	Grupo juntas	
	11	8000 89089	1	Gruppo snodo	Ball joint assy	Groupe joint a rotule	Kugelgelenkgruppe Kpl.	Grupo articulaciòn esferica	
	12	8000 98494	1	Gruppo guida stelo	Guide rod assy	Groupe guide tige	Pumpenstückführunggruppe	Grupo guja espiga	
	13	8000 98501	1	Corpo ammortizzatore	Damper case	Corps ammortisseur	Stossdämpferkörper	Corpo amortigüador	
	14	8000 98502	1	Serbatoio	Tank	Reservoir	Tank	Deposito	
	15	8000 98496	1	Fondello	Bottom	Fond	Bodenscheibe	Casquilo	
	16	8000 98497	1	Ghiera	Ring nut	Embout	Nutmutter	Virola	
	17	8000 98498	1	Ghiera	Ring nut	Embout	Nutmutter	Virola	
	18	8000 98499	1	Rosetta per molla	Washer	Rondelle	Scheibe	Arandela	
	19	8000 98503	1	Supporto serbatoio	Tank support	Support reservoir	Gastankhalterung	Soporte deposito	
	20	8000 98495	1	Gruppo guarnizioni per stelo	Rod gasket set	Jeu joints pour tige	Dichtungssatz für Pumpenstock	Serie juntas por espiga	
R	21	8000 88231	1	Olio ammortizzatore	Shock-absorber oil	Huile ammortisseur	Öl für Stossdampfer	Aceite amortigüador	
	22	80A0 69551	1	Protezione ammortizzatore	Guard	Protection	Schutz	Protección	
	23	8000 69429	2	Bussola	Bushing	Douille	Buchse	Manguito	
	24	8000 62726	2	Vite	Screw	Vis	Schraube	Tornillo	
	30	8A00 62797	1	Vite (M10x50 mm)	Screw (M10x50 mm)	Vis (M10x50 mm)	Schraube (M10x50 mm)	Tornillo (M10x50 mm)	
	31	8000 42022	1	Dado	Nut	Ecrou	Mutter	Tuerca	

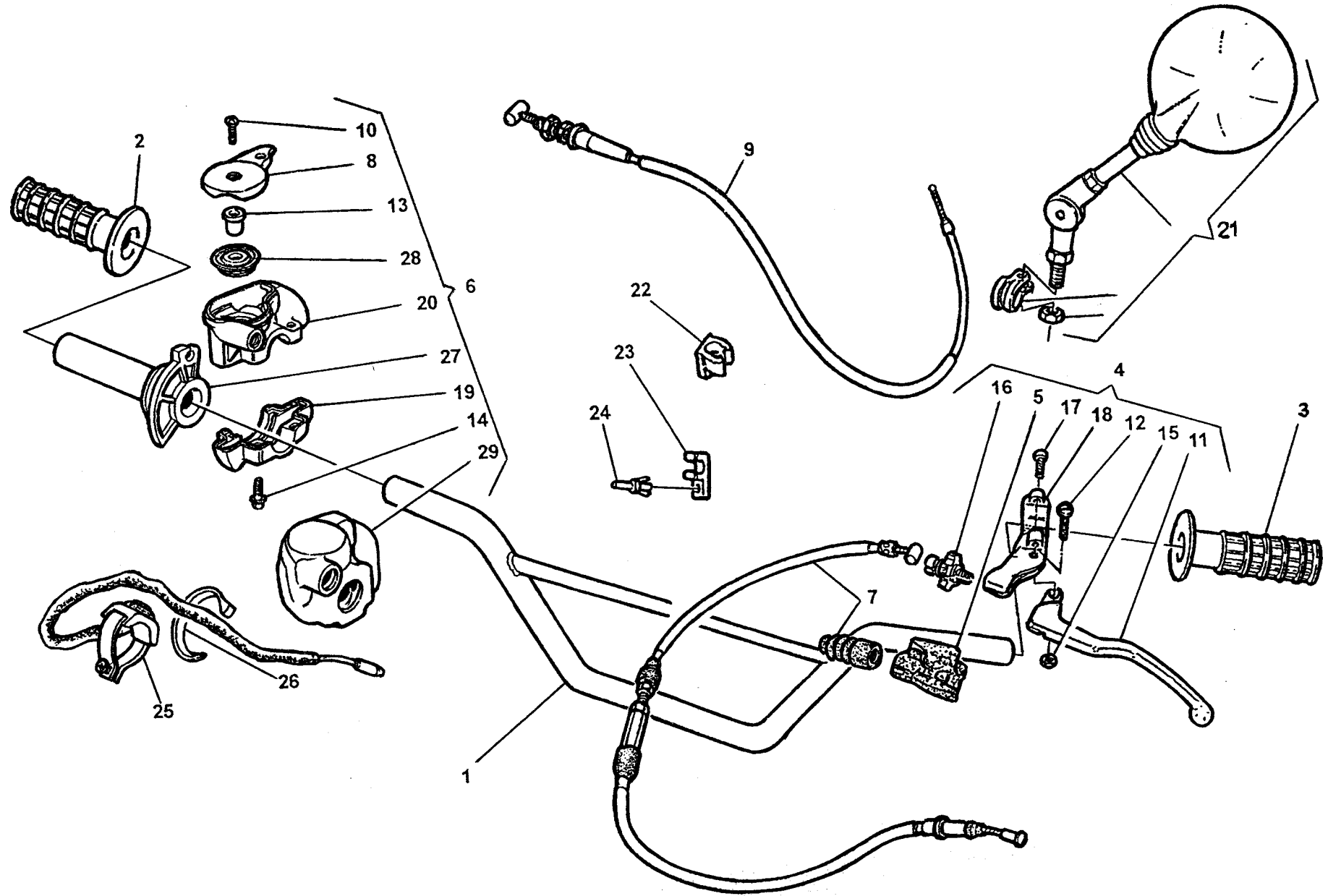

Note Notes Notas	Pos. No. N. Index Pos.	N. Cod. Code No. Nr. Code Code Nr N. Cod.	Q.tà Q.ty Q.te M.ge C.ad	DENOMINAZIONE	NAME	DESIGNATION	BESHREIBUNG	DENOMINACION	Validità Validity Validité Gültig Validez
	1	8000 88280	1	Manubrio (alluminio)	Handlebar (aluminium)	Guidon (aluminium)	Lenker (aluminium)	Manillar (aluminio)	
	2	8000 76688	1	Manopola destra	R.H. grip	Poignée G.	Griff R.	Manopla der.	
	3	8000 76687	1	Manopola sinistra	L.H. grip	Poignée G.	Griff L.	Manopla izq.	
	4	8000 75330	1	Com. frizione completo	Clutch control assy	Commande embrayage compl.	Führungssteuerung	Mando embrague compl.	
	5	8000 48917	1	Coprileva	Lever cover	Couvre levier	Hebeldeckel	Cubre-palanca	
	6	8000 88865	1	Comando gas completo	Throttle control cable	Commande gaz compl.	Gasgriff kpl.	Accionamiento acelerador com.	
	7	8000 90710	1	Trasmissione comando frizione	Clutch transm.	Transm. com. embrayage	Führungssteuerung	Trans. mando embrague com.	
	8	8000 93751	1	Coperchietto	Cover	Couvercle	Deckel	Tapa	
	9	8000 92308	1	Trasmissione gas	Throttle cable	Trasm. comm. gaz	Führungsteuerung des Gases	Tran. mando acelerador compl.	
	10	8000 50798	2	Vite	Screw	Vis	Schraube	Tornillo	
	11	8000 77737	1	Leva comando frizione	Clutch lever	Levier embrayage	Kupplungshebel	Palanca mando embrague	
	12	8000 38797	1	Vite	Screw	Vis	Schraube	Tornillo	
	13	8000 93750	1	Bussola	Bush	Douille	Buchse	Manguito	
	14	8000 62728	2	Vite	Screw	Vis	Schraube	Tornillo	
	15	8000 87812	1	Dado	Nut	Ecrou	Mutter	Tuerca	
	16	8000 48916	1	Gruppo registro	Adjuster set	Groupe reglage	Kupplungsreglergruppe	Grupo regul.	
	17	8000 62728	2	Vite	Screw	Vis	Schraube	Tornillo	
	18	8000 70698	1	Cavallotto	U-bolt	Cavalier	Bügelbolzen	Cabalete	
	19	8000 93747	1	Supporto inferiore	Lower support	Support inférieur	Untere Halterung	Soporte inferiør	
	20	8000 93746	1	Supporto superiore	Upper support	Support supérieur	Obere Halterung	Soporte superiør	
XYD	21	8000 65437	2	Specchio retrovisore compl.	Driving mirror	Rétroviseur	Rückspiegel	Espejo retrovisor	
	22	8000 61068	1	Molletta guida trasmissioni	Cable guida	Guide cable	Kabelführung	Guia-cable	
	23	8000 85220	1	Molletta guida trasmissioni	Cable guida	Guide cable	Kabelführung	Guia-cable	
	24	8000 48966	1	Rivetto	Rivet	Rivet	Niet	Remache	
UC	25	8000 96828	1	Pulsante arresto motore	Engine stop button	Poussoir	Knopf	Pùlsador	
UC	26	8000 71578	1	Fascetta	Clamp	Collier	Schelle	Banda	
	27	8000 93748	1	Tubo gas	Throttle pipe	Tuyau gaz	Gasrohr	Tubo aceleradør	
	28	8000 93749	1	Carrucola	Pulley	Poulie	Führungsrolle	Polea	
	29	8000 93752	1	Gommino coprigas	Rubber cover	Coverture caoutchouc	Gummistück	Goma	

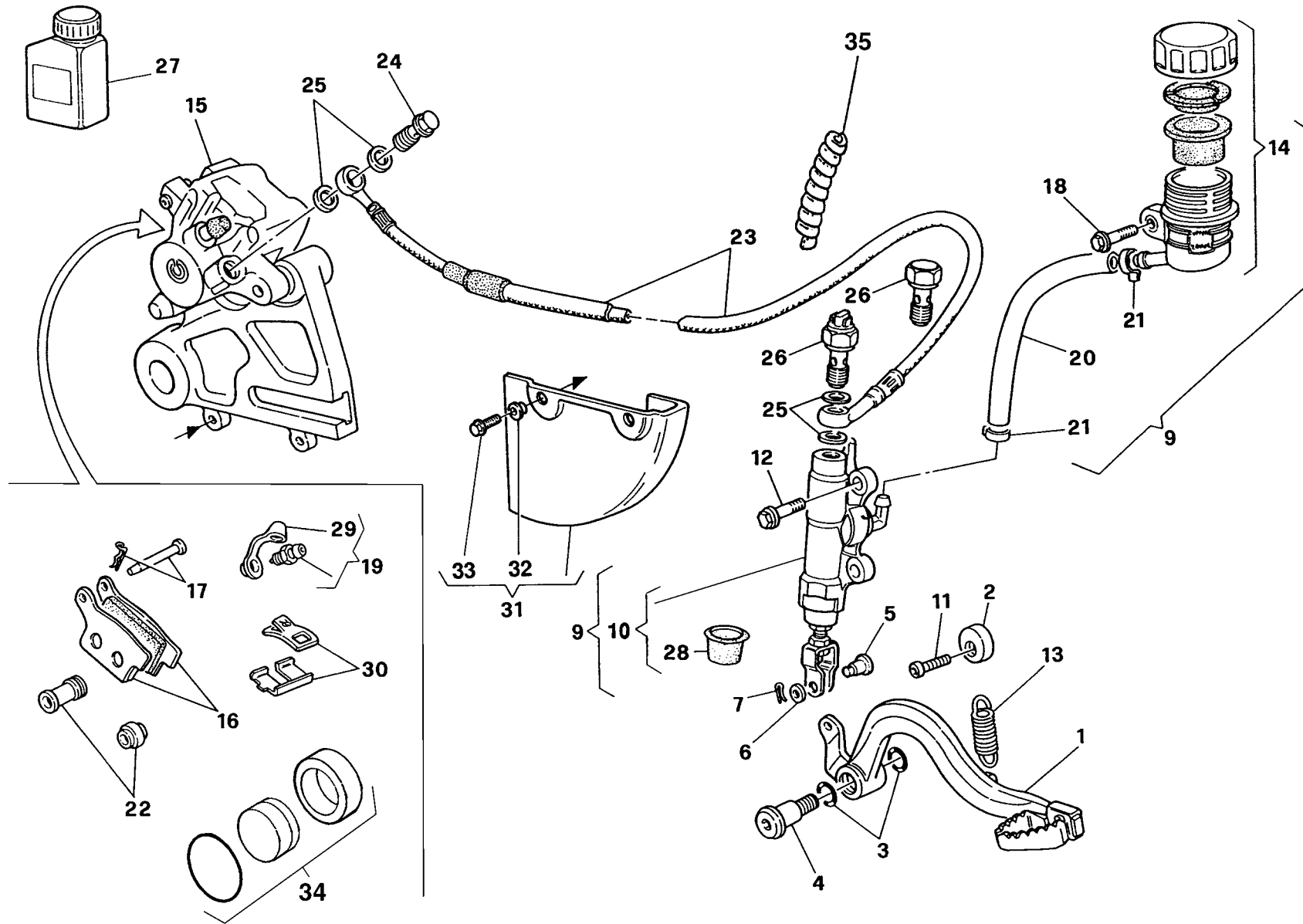

Note Notes Notas	Pos. No. N. Index Pos.	N. Cod. Code No. Nr. Code Code Nr N. Cod.	Q.tà Q.ty Q.te M.ge C.ad	DENOMINAZIONE	NAME	DESIGNATION	BESHREIBUNG	DENOMINACION	Validità Validity Validité Gültig Validez
	1	8A00 73343	1	Pedale comando freno	Brake control pedal	Pedal comm. frein	Bremspedal	Pedal accionamiento freno	
	2	8000 69125	1	Camma	Cam	Came	Nocken	Exéntrico	
	3	8000 22551	2	Anello OR	O-Ring	Bague OR	O-Ring	Anillo OR	
	4	8000 55902	1	Vite	Screw	Vis	Schraube	Tornillo	
	5	8000 70696	1	Perno	Pin	Pivot	Bolzen	Perno	
	6	8000 56377	1	Rosetta	Washer	Rondelle	Scheibe	Arandela	
	7	64N1 20068	1	Copiglia	Split pin	Goupille	Splint	Clavija	
	9	8A00 76026	1	Pompa comando freno compl.	Brake pump assy	Pompe frein complet	Bremspumpe kl.	Bomba freno compl.	
	10	8000 76338	1	Pompa freno	Brake pump	Pompe frein	Bremspumpe	Bomba freno	
	11	8A00 55241	1	Vite	Screw	Vis	Schraube	Tornillo	
	12	8000 62727	2	Vite	Screw	Vis	Schraube	Tornillo	
	13	8000 55903	1	Molla	Spring	Ressort	Feder	Resorte	
	14	8000 61078	1	Serbatoio olio completo	Oil tank assy	Reservoir huile compl.	Öltank Kpl.	Depósito aceite completo	
	15	8000 99729	1	Pinza freno completa	Brake caliper assy	Pince de frein, compl.	Bremszange, Kpl.	Pinza freno compl.	
	16	8000 79072	1	Coppia pastiglie	Pads pair	Paire plaquettes	Bremsbelagpaar	Pareja pastillas	
R	16	8A00 79072	1	Coppia pastiglie sinterizzate	Pads pair sinterized	Paire plaquettes frittage	Bremsbelagpaar sistem	Pareja pastillas sinterizar	
	17	8000 A0936	1	Perno	Pin	Pivot	Bolzen	Perno	
	18	8000 62725	1	Vite	Screw	Vis	Schraube	Tornillo	
	19	8000 A0931	1	Spurgo	Spurgo	Drain	Entleerung	Purga	
	20	8L00 66179	1	Tubazione	Pipe	Tuyau	Rohr	Tubo	
	21	8000 42349	2	Molletta	Spring	Ressort	Feder	Resorte	
	22	8000 79066	1	Cuffia	Boots	Poussiers	haube	Gorro	
	23	8000 88863	1	Tubo mandata olio	Pipe	Tuyau	Rohr	Tubo	
	24	8000 57155	1	Vite	Screw	Vis	Schraube	Tornillo	
	25	8000 21480	4	Rosetta	Washer	Rondelle	Scheibe	Arandela	
W	26	8000 94849	1	Interruttore stop posteriore	Rear stop switch	Interrupteur stop	Stopschalter	Interruptor stop	
UC	26	8000 57155	1	Vite	Screw	Vis	Schraube	Tornillo	
R	27	8000 71445	1	Olio freni	Brake oil	Huile de frein	BremsÖl	Aceite freno	
	28	8000 79075	1	Cuffia	Boot	Poussier	haube	Gorro	
	29	8000 53259	1	Parapolvere	Boots	Para-poudre	Schutzhaube	Para-polvo	
	30	8000 85932	1	Molla-lamierino	Spring-steel clip	Ressort	Feder	Rresorte	
R	31	8000 80208	1	Protezione disco	Guard	Protection	Schut	Protecion	
R	32	8000 45495	2	Bussola	Bushing	Douille	Buchse	Manguito	

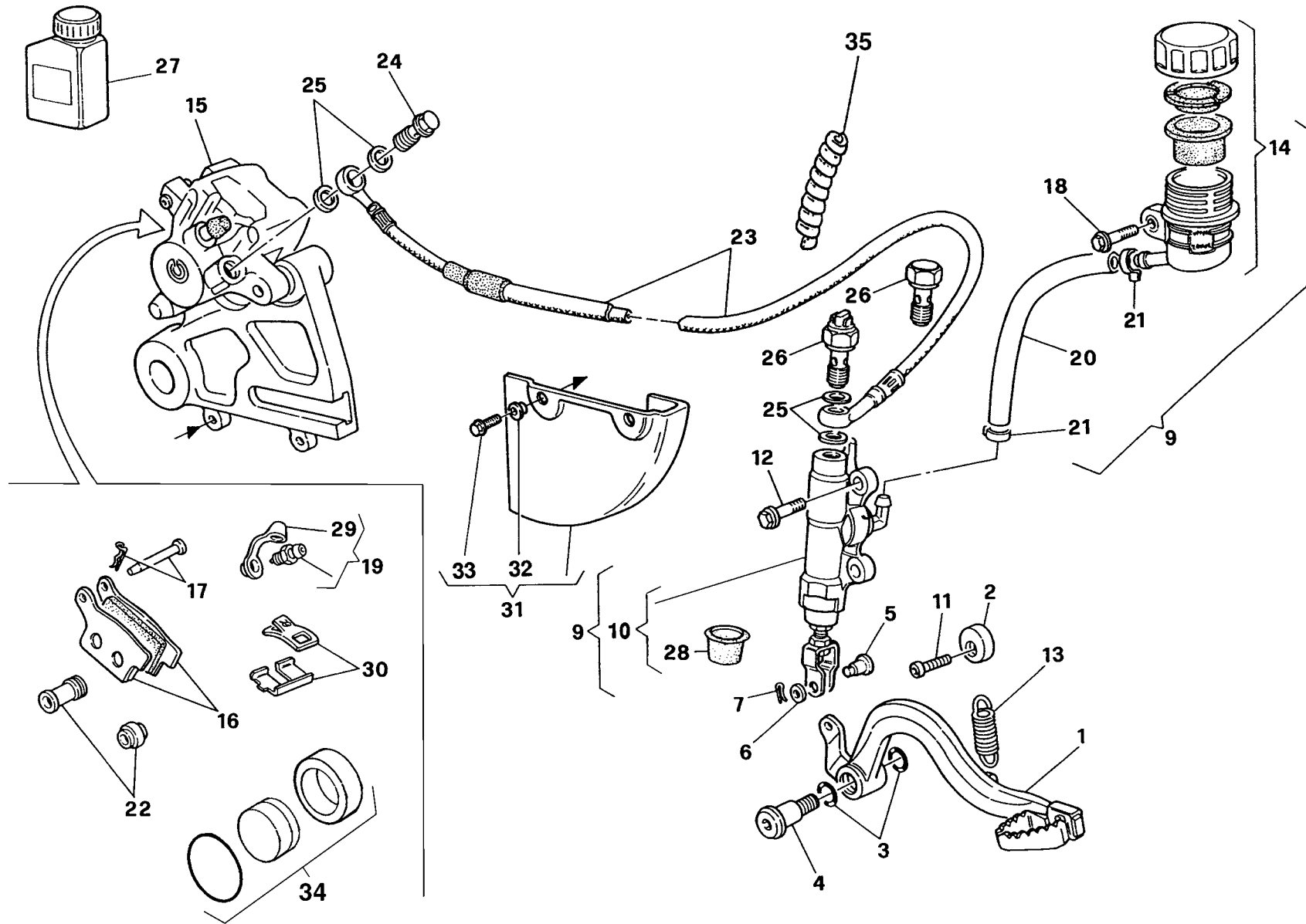

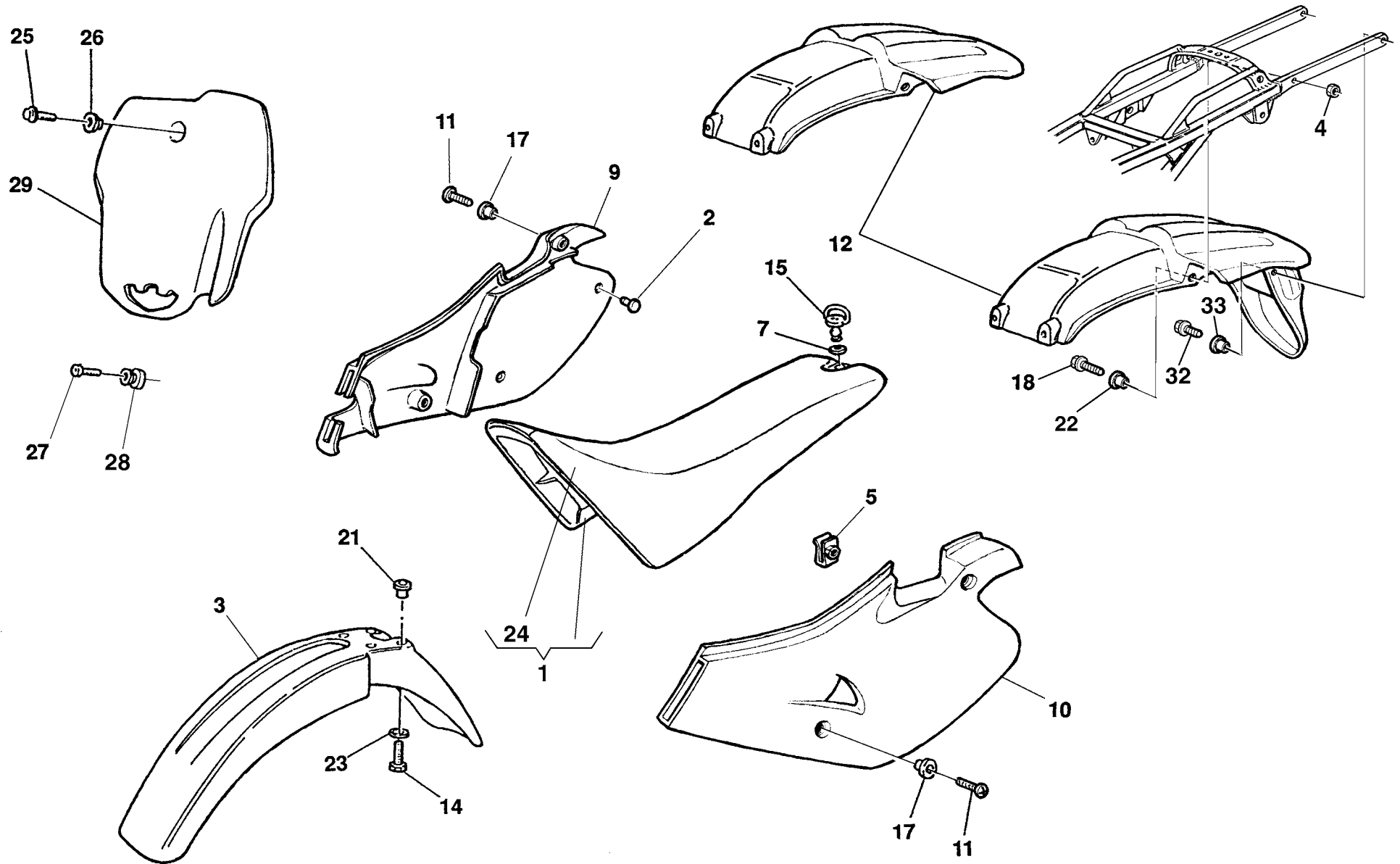

Note Notes Notas	Pos. No. Index Pos.	N. Cod. Code No. Nr. Code Code Nr N. Cod.	Q.tà Q.ty Q.te M.ge C.ad	DENOMINAZIONE	NAME	DESIGNATION	BESHREIBUNG	DENOMINACION	Validità Validity Validité Gültig Validez
	1	8000 A0050	1	Sella	Seat	Siège	Sattel	Sillín	
	2	8000 45490	2	Gommino anticalore	Rubber pad	Pièce caoutchouc	Gummstück	Junta de goma	
	3	8000 A1589	1	Parafango anteriore	Front mudguard	Garde-boue avant	Vord. Kotfluegel	Guarda-barros del.	
	4	8000 61313	2	Dado	Nut	Ecrou	Mutter	Tuerca	
	5	8000 46893	2	Dado	Nut	Ecrou	Mutter	Tuerca	
	7	8000 69149	1	Rosetta elastica	Spring washer	Rondelle élastique	Federscheibe	Arandela elástica	
	9	8AB0 88866	1	Pannello destro	R.H. panel	Panneau, D.	Streifen. R.	Panel Der.	
	10	8AB0 88867	1	Pannello sinistro	L.H. panel	Panneau, G.	Streifen. L.	Panel Izq.	
	11	8000 62727	4	Vite	Screw	Vis	Schraube	Tornillo	
W	12	8000 A0545	1	Parafango post.	Rear mudguard	Garde-boue arriere	Hint. Kotfluegel	Guarda-barros tras.	
UC	12	8000 A0546	1	Parafango post.	Rear mudguard	Garde-boue arriere	Hint. Kotfluegel	Guarda-barros tras.	
	14	8000 62727	4	Vite	Screw	Vis	Schraube	Tornillo	
	15	8000 69148	1	Perno	Pin	Pivot	Bolzen	Perno	
	17	8000 69429	4	Boccola	Bushing	Douille	Buchse	Casquillo	
	18	8000 62728	2	Vite (M6x20mm)	Screw (M6x20mm)	Vis (M6x20mm)	Schraube (M6x20mm)	Tornillo (M6x20mm)	
	21	8000 69429	4	Bussola	Bushing	Douille	Buchse	Manguito	
	22	8000 69429	2	Bussola	Bushing	Douille	Buchse	Manguito	
	23	8000 48814	4	Rosetta	Washer	Rondelle	Scheibe	Arandela	
	24	8000 A0051	1	Rivestimento sella	Saddle covering	Revetement selle	Sattelverkleidung	Revestimiento sillin	
UC	25	8C00 67997	1	Vite	Screw	Vis	Schraube	Tornillo	
UC	26	8B00 69282	1	Bussola	Bushing	Douille	Buchse	Manguito	
UC	27	8000 62726	2	Vite	Screw	Vis	Schraube	Tornillo	
UC	28	8000 A0241	2	Attacco portanumero	Spacer	Entretoise	Distanzstück	Separador	
UC	29	80B0 87800	1	Portanumero	Front number holder	Portenumero	Nummerträger	Portanumero	
W	32	8000 62726	2	Vite (M6x14mm)	Screw (M6x14mm)	Vis (M6x14mm)	Schraube (M6x14mm)	Tornillo (M6x14mm)	
W	33	8000 45495	2	Bussola	Bushing	Douille	Buchse	Manguito	

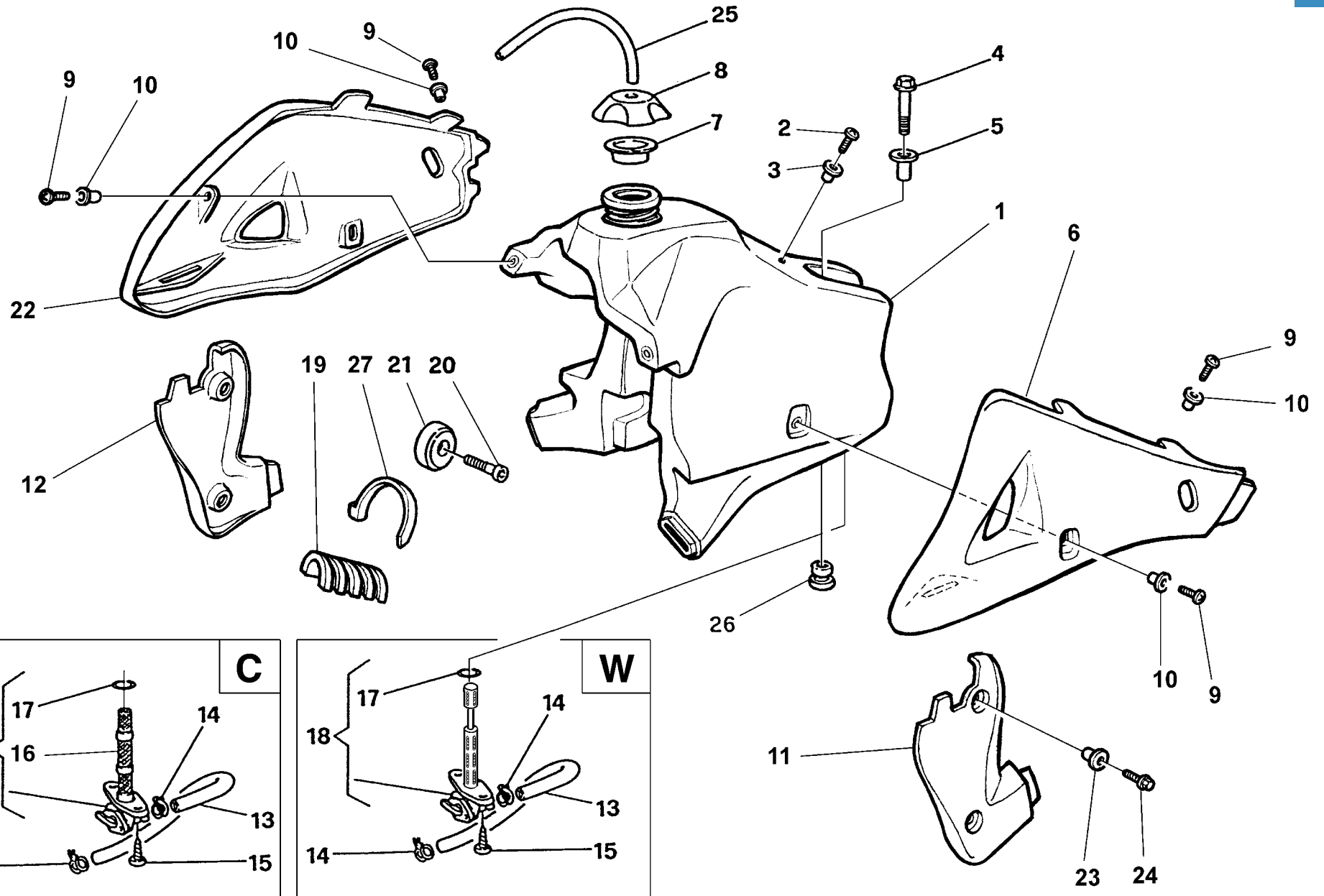

Note Notes Notas	Pos. No. Index Pos.	N. Cod. Code No. Nr. Code Code Nr N. Cod.	Q.tà Q.ty Q.te M.ge C.ad	DENOMINAZIONE	NAME	DESIGNATION	BESHREIBUNG	DENOMINACION	Validità Validity Validité Gültig Validez
C	1	8000 88877	1	Serbatoio carburante (l 8,5)	Fuel tank (l 8,5)	Réservoir à carburant (l 8,5)	Tank (l 8,5)	Depósito gasolina (l 8,5)	
W	1	8000 88862	1	Serbatoio carb. (l 10,2)	Fuel tank (l 10,2)	Réservoir carb. (l 10,2)	Tank (l 10,2)	Dep. gasolina (l 10,2)	
RU	1	8000 88877	1	Serbatoio carburante (l 8,5)	Fuel tank (l 8,5)	Réservoir à carburant (l 8,5)	Tank (l 8,5)	Depósito gasolina (l 8,5)	
R	1	8000 88862	1	Serbatoio maggiorato (l 10,2)	Fuel lager tank (l 10,2)	Rés. grande capacite (l 10,2)	Überdimensioniert Tank (l 10,2)	Depósito gasolina ampliado (l 10,2)	
	2	60N1 04134	1	Vite	Screw	Vis	Schraube	Tornillo	
	3	8000 66238	1	Distanziale	Spacer	Entretoise	Distanzstück	Separador	
	4	8A00 67545	1	Vite	Screw	Vis	Schraube	Tornillo	
	5	8000 69036	1	Distanziale	Spacer	Entretoise	Distanzstück	Separador	
	6	8AB0 88868	1	Convogliatore SX	L. side panel	Flanc G.	Flanke L.	Lateral I.	
	7	8000 56381	1	Guarnizione	Gasket	Garniture	Dichtung	Junta	
	8	8000 94098	1	Tappo	Plug	Bouchon	Verschluss	Tapón	
	9	8000 36467	8	Vite	Screw	Vis	Schraube	Tornillo	
	10	8000 45495	8	Bussola	Bushing	Douille	Buchse	Manguito	
	11	8000 93883	1	Protezione Sx	L.H. guard	Protection G.	Schutz Linke	Protección izquierda	
	12	8000 93017	1	Protezione Dx	R.H. guard	Protection D.	Schutz Rechte	Protección derecha	
	13	8000 94010	1	Condotta benzina	Pipe	Tuyau	Rohr	Tubo	
	14	80A0 42349	2	Fascetta	Split ring	Anneau ressort	Sprengring	Anillo elástico	
	15	8000 37745	2	Vite	Screw	Vis	Schraube	Tornillo	
C	16	8000 38748	1	Filtro benzina	Fuel filter	Filtre essence	Benzinfilter	Filtro gasolina	
C	17	8000 01199	1	Anello OR	O Ring	Bague OR	O-Ring	Anillo OR	
W	18	8000 A0339	1	Rubinetto completo	Cock assy	Robinet compl.	Kraftstoffahn, Kpl.	Llave de paso compl.	
C	18	8000 43592	1	Rubinetto completo	Cock assy	Robinet compl.	Kraftstoffahn, Kpl.	Llave de paso compl.	
	19	8000 94009	1	Tampone	Pad	Tampon	Stopfen	Tampón	
	20	8000 41240	2	Vite	Screw	Vis	Schraube	Tornillo	
	21	8000 40813	1	Tampone	Pad	Tampon	Stopfen	Tampón	
	22	8AB0 88869	1	Convogliatore DX	R. side panel	Flanc D.	Flanke R.	Lateral D.	
	23	8000 69429	4	Bussola	Bushing	Douille	Buchse	Manguito	
	24	8000 62727	4	Vite	Screw	Vis	Schraube	Tornillo	
	25	8S00 68873	1	Tubetto sfiato (L=380 mm)	Battery breather pipe	Event batterie	Batterieentlüfter	Tubo de purga batería	
	26	8000 69035	1	Gommino	Rubber pad	Pièce caoutchouc	Gummstück	Junta de goma	
	27	8000 50005	1	Fascetta	Split ring	Anneau ressort	Sprengring	Anillo elástico	

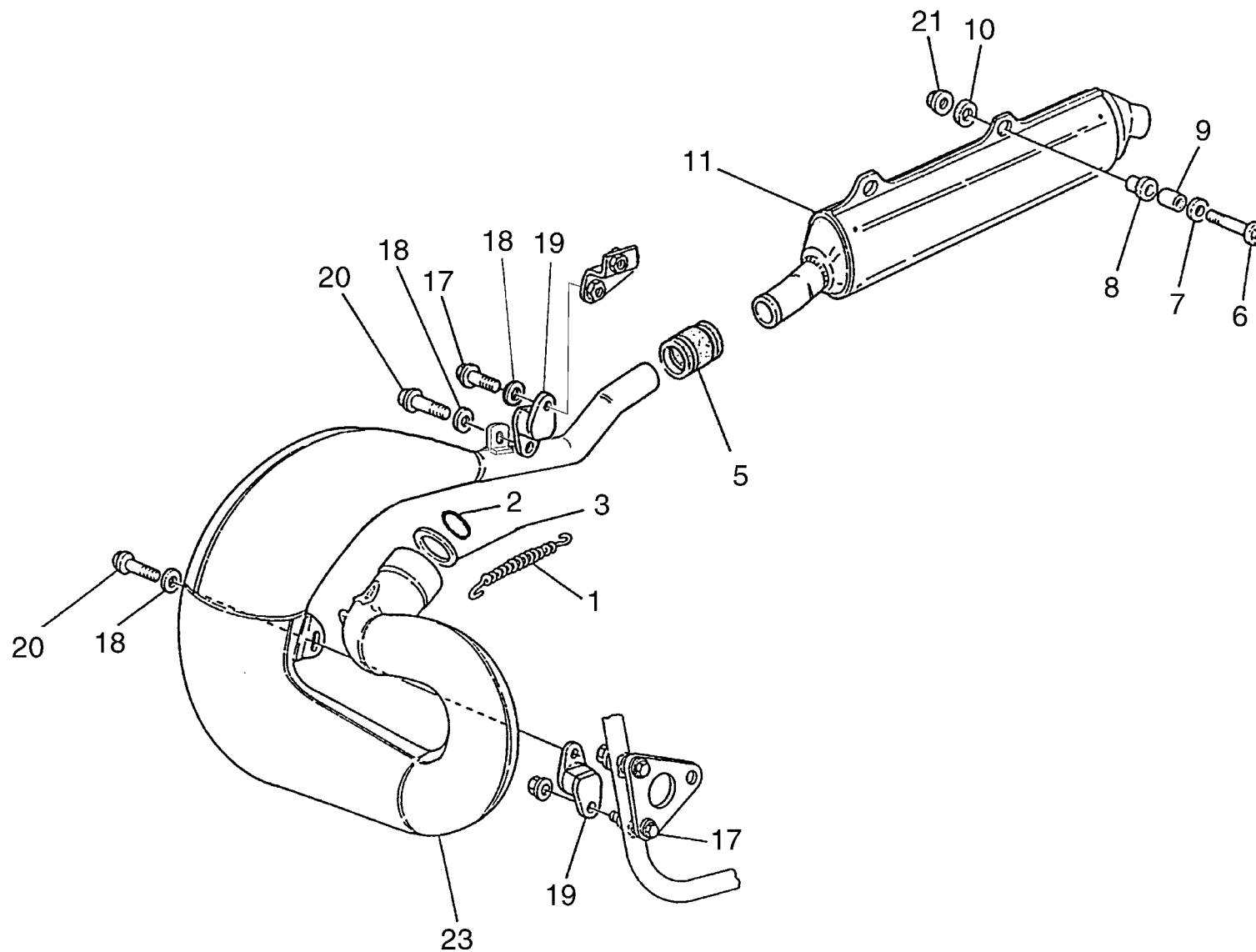

Note Notes Marke Notas	Pos. No. N. Index Pos.	N. Cod. Code No. Nr. Code Code Nr N. Cod.	Q.tà Q.ty Q.te M.ge C.ad	DENOMINAZIONE	NAME	DESIGNATION	BESHREIBUNG	DENOMINACION	Validità Validity Validité Gültig Validez
	1	8000 62341	2	Molla	Spring	Ressort	Feder	Resorte	
	2	8A00 31970	1	Anello OR	O Ring	Bague OR	O-Ring	Anillo OR	
	3	8A00 73541	1	Rosetta	Washer	Rondelle	Scheibe	Arandela	
	5	8000 92788	1	Gommino	Rubber pad	Pièce caoutchouc	Gummstück	Junta de goma	
	6	8000 62730	2	Vite	Screw	Vis	Schraube	Tornillo	
	7	1513 74301	2	Rosetta	Washer	Rondelle	Scheibe	Arandela	
	8	1514 10702	2	Gommino	Rubber pad	Pièce caoutchouc	Gummstück	Junta de goma	
	9	8C00 70379	2	Distanziale	Spacer	Entretoise	Distanzstück	Separador	
	10	1513 41401	2	Gommino	Rubber pad	Pièce caoutchouc	Gummstück	Junta de goma	
W	11	8000 93009	1	Silenziatore completo	Exhaust silencer	Silencieux d'échappement	Schalldämpfer	Silenciador de escape	
C	11	8000 93023	1	Silenziatore completo	Exhaust silencer	Silencieux d'échappement	Schalldämpfer	Silenciador de escape	
U	11	8000 A0491	1	Silenziatore completo	Exhaust silencer	Silencieux d'échappement	Schalldämpfer	Silenciador de escape	
	17	8000 62726	2	Vite	Screw	Vis	Schraube	Tornillo	
	18	8000 45499	4	Rosetta piana	Washer	Rondelle	Scheibe	Arandela	
	19	8000 69113	2	Antivibrante	Silent-block	Antivibration	Schwingungsdämpfer	Anti-vibrador	
	20	8000 62725	2	Vite	Screw	Vis	Schraube	Tornillo	
	21	8000 44240	2	Dado	Nut	Ecrou	Mutter	Tuerca	
W	23	8000 A0144	1	Tubo di scarico	Exhaust pipe	Tuyau d'échapp.	Auspuffrohr	Tubo de escape	
C	23	8A00 A0144	1	Tubo di scarico	Exhaust pipe	Tuyau d'échapp.	Auspuffrohr	Tubo de escape	
U	23	8B00 A0144	1	Tubo di scarico	Exhaust pipe	Tuyau d'échapp.	Auspuffrohr	Tubo de escape	

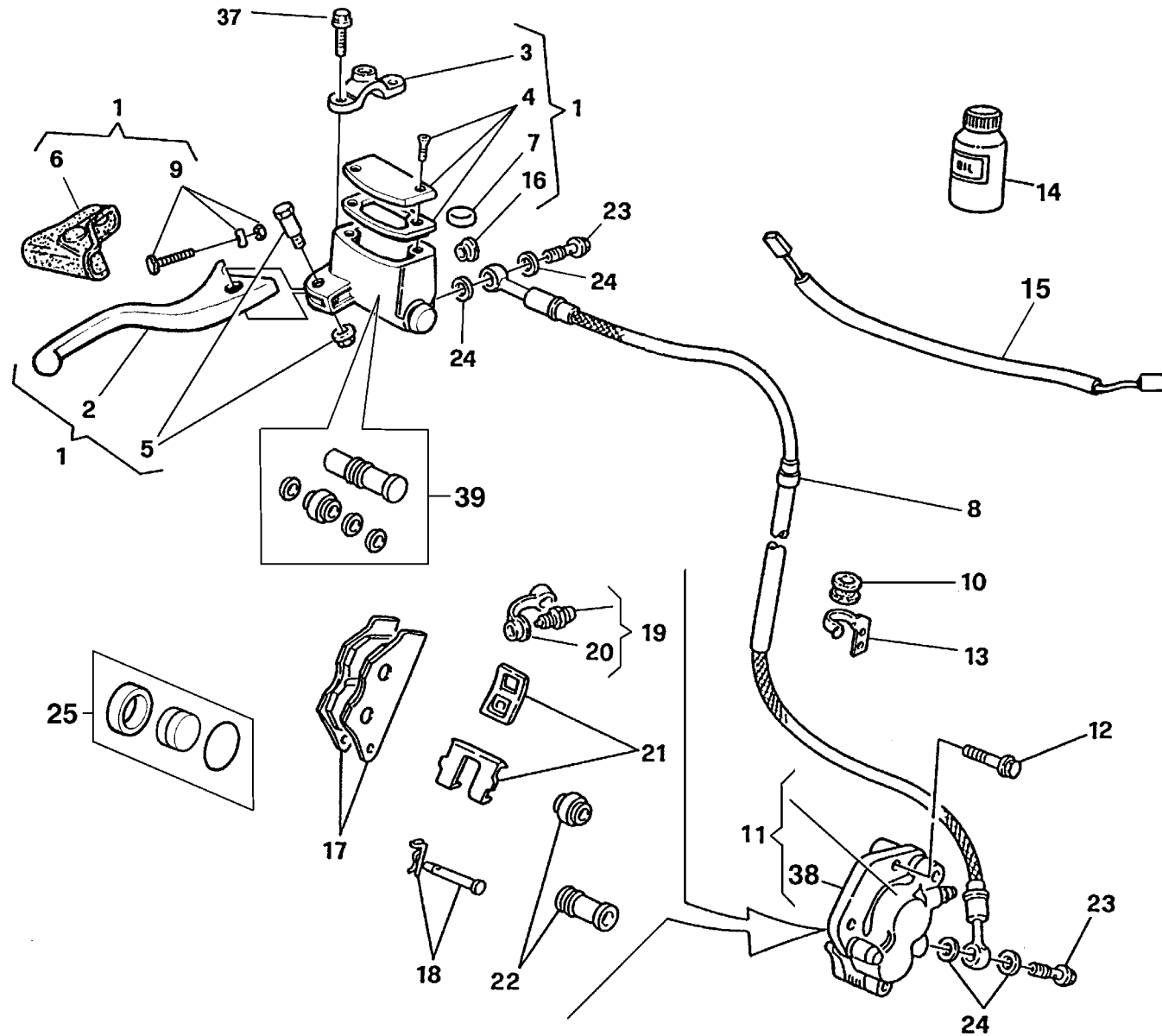



CR-WR 250 /2004

TAVOLA
DRAWING
TABLE
BILD
TABLA

22

FRENO IDRAULICO ANTERIORE - FRONT HYDRAULIC BRAKE
FREIN HYDRAULIQUE AVANT - VORDERBREMSE
FRENO HIDRAULICO DELANTERO

Note Notes Notas	Pos. No. Index Pos.	N. Cod. Code No. Nr. Code Code Nr N. Cod.	Q.tà Q.ty Q.te M.ge C.ad	DENOMINAZIONE	NAME	DESIGNATION	BESHREIBUNG	DENOMINACION	Validità Validity Validité Gültig Validez
W	1	8000 99715	1	Pompa comando freno ant.	Brake pump	Pompe frein	Bremspumpe	Bomba freno	
CU	1	8000 96831	1	Pompa comando freno ant.	Brake pump	Pompe frein	Bremspumpe	Bomba freno	
W	2	8000 96830	1	Leva	Lever	Levier	Hebel	Palanca	
CU	2	8000 96830	1	Leva	Lever	Levier	Hebel	Palanca	
	3	8000 94125	1	Cavallotto	U-bolt	Cavalier	Bügelbolzen	Caballote	
	4	8000 94126	1	Kit tappo	Plug kit	Bouchon kit	Verschluss Gruppe	Kit tapón	
	5	8000 94127	1	Perno	Pin	Pivot	Bolzen	Perno	
	6	8000 94128	1	Cappuccio	Cap	Capuchon	Kappe	Capuchon	
	7	8000 79099	1	Antiemulsione	Antiemulsion	Antiemulsion	Eulsionwidriger	Antiemulsion	
W	8	8000 A0600	1	Tubo mandata olio	Pipe	Tuyau	Rohr	Tubo	
C	8	8000 93036	1	Tubo mandata olio	Pipe	Tuyau	Rohr	Tubo	
	9	8000 A0927	1	Regolazione	Adjuster	Registre	Regler	Regulizador	
	10	8000 71806	1	Occhiello passatubo	Fairlead	Passe câble	Kabelführung	Prensa cable	
	11	8000 99674	1	Pinza freno	Brake caliper	Etrier frein	Bremssattel	Pinza	
	12	8000 62733	2	Vite	Screw	Vis	Schraube	Tornillo	
W	13	8000 90104	1	Piastrina di ritegno	Plate	Plaque	Platte	Placa	
UC	13	8000 72022	1	Piastrina di ritegno	Plate	Plaque	Platte	Placa	
R	14	8000 71445	1	Olio freni	Brake oil	Huile frein	Bremsol	Aceite freni	
XW	15	8000 A0929	1	Interruttore stop	Stop switch	Interrupteur stop	Stopschalter	Interruptor stop	
	16	8000 49654	1	Oblò	Inspection plug	Capuchon de inspection	Stopfen	Portilla	
	17	8000 96934	1	Coppia pastiglie	Pads pair	Paire plaquettes	Bremsbelagpaar	Pareja pastillas	
	18	8000 A0932	1	Perno	Pin	Pivot	Bolzen	Perno	
	19	8000 A0931	1	Spurgo	Spurgo	Drain	Entleerung	Purga	
	20	8000 53259	1	Parapolvere	Boots	Para-poudre	Schutzhaube	Para-polvo	
	21	8000 79065	1	Molla-lamierino	Spring-steel clip	Ressort	Feder	Rresorte	
	22	8000 79066	1	Cuffie	Boots	Poussiers	haube	Gorro	
	23	8000 57155	2	Vite	Screw	Vis	Schraube	Tornillo	
	24	8000 21480	4	Rosetta	Washer	Rondell'e	Scheibe	Arandela	
	25	8000 A0930	1	Pistone	Piston	Piston	Kolben	Pistón	
	37	8000 62729	2	Vite	Screw	Vis	Schraube	Tornillo	
	38	8000 99859	1	Supporto	Holder	Support	Halterung	Soporte	
	39	8000 A1137	1	Flottante	Pin	Pivot	Bolzen	Perno	

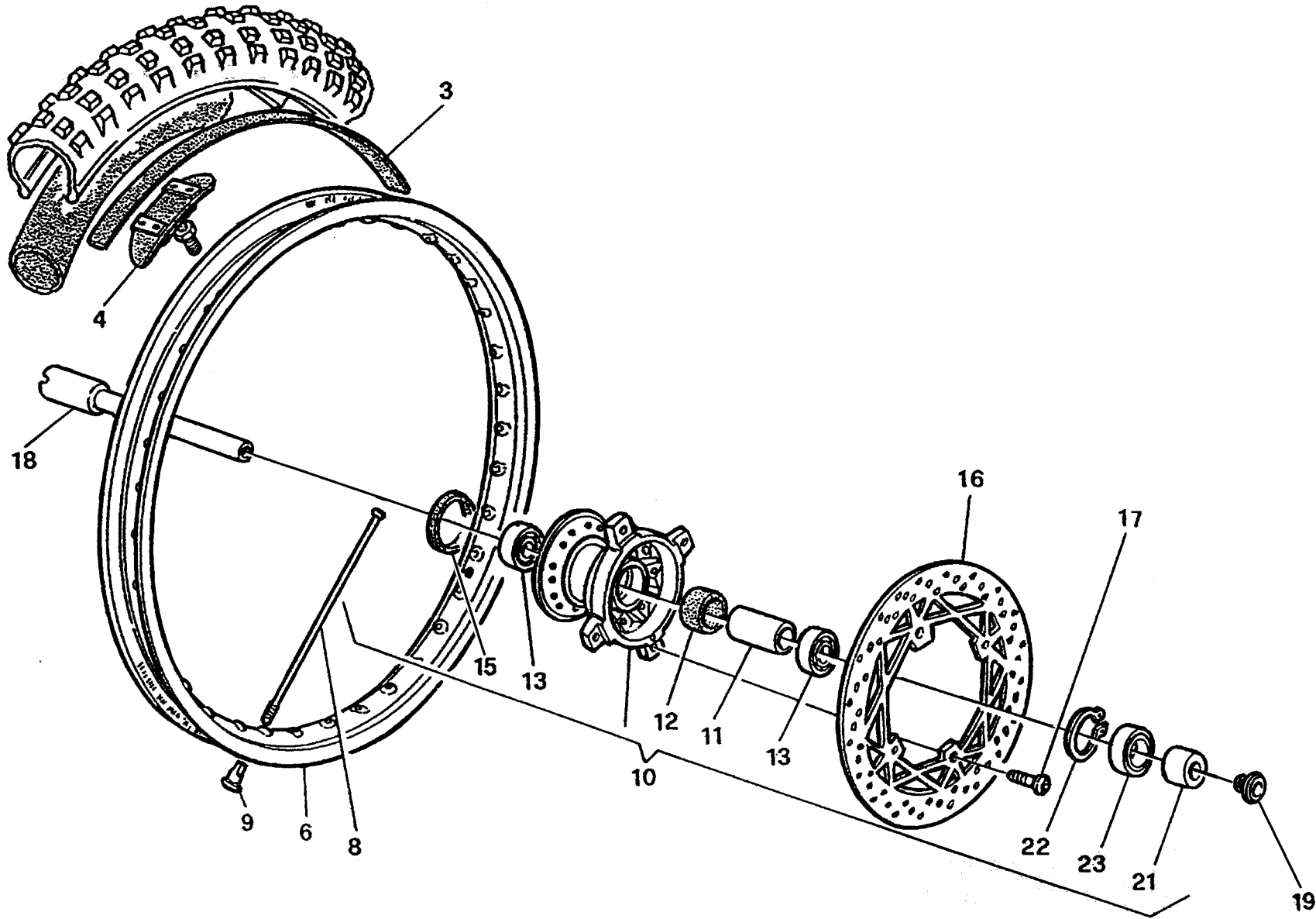

Note Notes Notas	Pos. No. N. Index Pos.	N. Cod. Code No. Nr. Code Code Nr N. Cod.	Q.tà Q.ty Q.te M.ge C.ad	DENOMINAZIONE	NAME	DESIGNATION	BESHREIBUNG	DENOMINACION	Validità Validity Validité Gültig Validez
	3	8000 13346	1	Fascia copriraggi	Rim strip	Bande	Band	Banda	
	4	8000 49036	1	Staffa fermacopertone	Bracket	Etrier	Buegel	Brida	
	6	8A00 53504	1	Cerchio (1,6x21")	Rim (1,6x21")	Jante (1,6x21")	Felge (1,6x21")	Llanta (1,6x21")	
	8	8000 A0080	36	Raggio	Spoke	Bras	Speiche	Radio	
	9	8000 A0081	36	Nipplo	Nipple	Nipple	Nippel	Nipple	
	10	8000 96838	1	Mozzo completo	Hub assy	Moyeau compl.	Radnabe, Kpl.	Cubo compl.	
	11	8000 96928	1	Distanziale	Spacer	Entretoise	Distanzstück	Separador	
	12	8000 92797	1	Portadistanziale	Spacer holder	Porte-entretoise	Abstandstuckhalter	Porta-distancial	
	13	8000 84938	2	Cuscinetto a sfere (ø25xø42x9 mm)	Ball bearing (ø25xø42x9 mm)	Roulement à billes (ø25xø42x9 mm)	Kugellager (ø25xø42x9 mm)	Cojinete de bolas (ø25xø42x9 mm)	
	15	8A00 92986	1	Anello di tenuta (ø28xø50x5 mm)	Seal ring (ø28xø50x5 mm)	Bague d'étanchéité (ø28xø50x5 mm)	Dichtungsring (ø28xø50x5 mm)	Anillo de retención (ø28xø50x5 mm)	
	16	8000 99632	1	Disco freno (Ø260 mm)	Brake disc (Ø260 mm)	Disque frein (Ø260 mm)	Bremsscheibe (Ø260 mm)	Disco freno (Ø260 mm)	
	17	8A00 55241	4	Vite	Screw	Vis	Schraube	Tornillo	
	18	8000 96932	1	Perno ruota	Pin	Pivot	Bolzen	Perno rueda	
	19	8000 96933	1	Vite	Screw	Vis	Schraube	Tornillo	
	21	8000 96930	1	Distanziale	Spacer	Entretoise	Distanzstück	Separador	
	22	66N0 21270	1	Anello SEEGER	SEEGER ring	Anneau SEEGER	Ring SEEGER	Anillo SEEGER	
	23	8000 22966	1	Anello di tenuta (ø32xø42x7 mm)	Seal ring (ø32xø42x7 mm)	Bague d'étanchéité (ø32xø42x7 mm)	Dichtungsring (ø32xø42x7 mm)	Anillo de retención (ø32xø42x7 mm)	

Note Notes Notas	Pos. No. N. Index Pos.	N. Cod. Code No. Nr. Code Code Nr N. Cod.	Q.tà Q.ty Q.te M.ge C.ad	DENOMINAZIONE	NAME	DESIGNATION	BESHREIBUNG	DENOMINACION	Validità Validity Validité Gültig Validez
W	3	8000 01688	1	Fascia copriraggi	Rim strip	Bande	Band	Banda	
C	3	8000 10777	1	Fascia copriraggi	Rim strip	Bande	Band	Banda	
	4	8000 54073	1	Staffa fermacopertone	Bracket	Etrier	Buegel	Brida	
W	5	8A00 55860	1	Cerchio (2,15 x 18")	Rim (2,15 x 18")	Jante (2,15 x 18")	Felge (2,15 x 18")	Llanta (2,15 x 18")	
C	5	8A00 58929	1	Cerchio (2,15 x 19")	Rim (2,15 x 19")	Jante (2,15 x 19")	Felge (2,15 x 19")	Llanta (2,15 x 19")	
W	6	8000 A0085	36	Raggio	Spoke	Bras	Speiche	Radio	
C	6	8A00 A0085	36	Raggio	Spoke	Bras	Speiche	Radio	
	7	8000 A0086	36	Nipplo	Nipple	Nipple	Nippel	Nipple	
	8	8000 96937	1	Mozzo completo	Hub assy	Moyeau compl.	Radnabe, Kpl.	Cubo compl.	
	9	8000 92414	1	Distanziale	Spacer	Entretoise	Distanzstück	Separador	
	10	8B00 26846	1	Cuscinetto (ø25xø47x16 mm)	Bearing (ø25xø47x16 mm)	Roulement (ø25xø47x16 mm)	Kugellager (ø25xø47x16 mm)	Cojinete (ø25xø47x16 mm)	
	11	8000 92797	1	Porta distanziale	Spacer	Entretoise	Distanzstück	Separador	
	12	8000 96938	2	Distanziale	Spacer	Entretoise	Distanzstück	Separador	
	14	8000 A0692	1	Disco freno (Ø220 mm)	Brake disc (Ø220 mm)	Disque frein (Ø220 mm)	Bremsscheibe (Ø220 mm)	Disco freno (Ø220 mm)	
	15	8000 62726	4	Vite	Screw	Vis	Schraube	Tornillo	
S	16	8B00 96837	1	Corona (Z = 48)	Ring gear (Z = 48)	Couronne (Z = 48)	Kranz (Z = 48)	Corona (Z = 48)	
R	16	8A00 96837	1	Corona (Z = 47)	Ring gear (Z = 47)	Couronne (Z = 47)	Kranz (Z = 47)	Corona (Z = 47)	
R	16	8C00 96837	1	Corona (Z = 49)	Ring gear (Z = 49)	Couronne (Z = 49)	Kranz (Z = 49)	Corona (Z = 49)	
R	16	8D00 96837	1	Corona (Z = 50)	Ring gear (Z = 50)	Couronne (Z = 50)	Kranz (Z = 50)	Corona (Z = 50)	
	17	8C00 40796	6	Vite (M8x25 mm)	Screw (M8x25 mm)	Vis (M8x25 mm)	Schraube (M8x25 mm)	Tornillo (M8x25 mm)	
	18	8000 43928	6	Dado	Nut	Ecrou	Mutter	Tuierca	
	19	8000 96940	1	Perno	Pin	Pivot	Bolzen	Perno	
	20	8A00 26846	2	Cuscinetto (ø25xø47x12 mm)	Bearing (ø25xø47x12 mm)	Roulement (ø25xø47x12 mm)	Kugellager (ø25xø47x12 mm)	Cojinete (ø25xø47x12 mm)	
	21	8000 93072	1	Dado	Nut	Ecrou	Mutter	Tuerca	
	24	66N0 21272	1	Anello SEEGER	SEEGER ring	Anneau SEEGER	Ring SEEGER	Anillo SEEGER	
	26	8000 89572	2	Anello di tenuta (ø32xø47x7 mm)	Seal ring (ø32xø47x7 mm)	Bague d'étanchéité (ø32xø47x7 mm)	Dichtungsring (ø32xø47x7 mm)	Anillo de retención (ø32xø47x7 mm)	
W	27	8000 65442	1	Catena 5/8"x1/4" (112 maglie)	Chain 5/8"x1/4" (112 link)	Chaîne 5/8"x1/4" (112 maillon)	Kette 5/8"x1/4" (112 Schake)	Cadena 5/8"x1/4" (112 malla)	
WA	27	8A00 79783	1	Catena 5/8"x1/4" (112 maglie)	Chain 5/8"x1/4" (112 link)	Chaîne 5/8"x1/4" (112 maillon)	Kette 5/8"x1/4" (112 Schake)	Cadena 5/8"x1/4" (112 malla)	
C	27	8A00 79785	1	Catena 5/8"x1/4" (112 maglie)	Chain 5/8"x1/4" (112 link)	Chaîne 5/8"x1/4" (112 maillon)	Kette 5/8"x1/4" (112 Schake)	Cadena 5/8"x1/4" (112 malla)	
CA	27	8A00 56768	1	Catena 5/8"x1/4" (112 maglie)	Chain 5/8"x1/4" (112 link)	Chaîne 5/8"x1/4" (112 maillon)	Kette 5/8"x1/4" (112 Schake)	Cadena 5/8"x1/4" (112 malla)	
W	28	8000 79789	1	Giunto	Master link	Joint	Kupplung	Junta	
WA	28	8000 65464	1	Giunto	Master link	Joint	Kupplung	Junta	

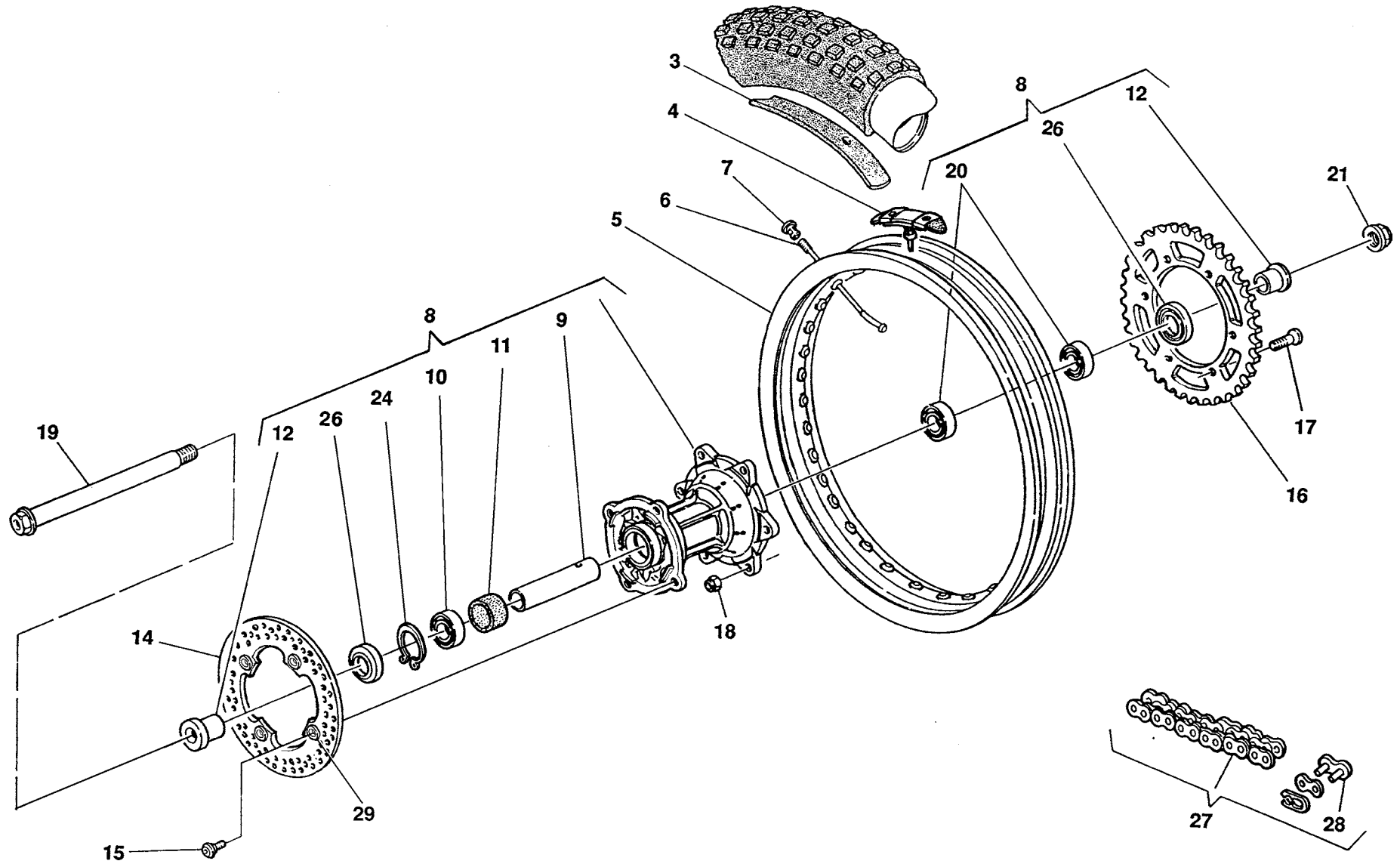

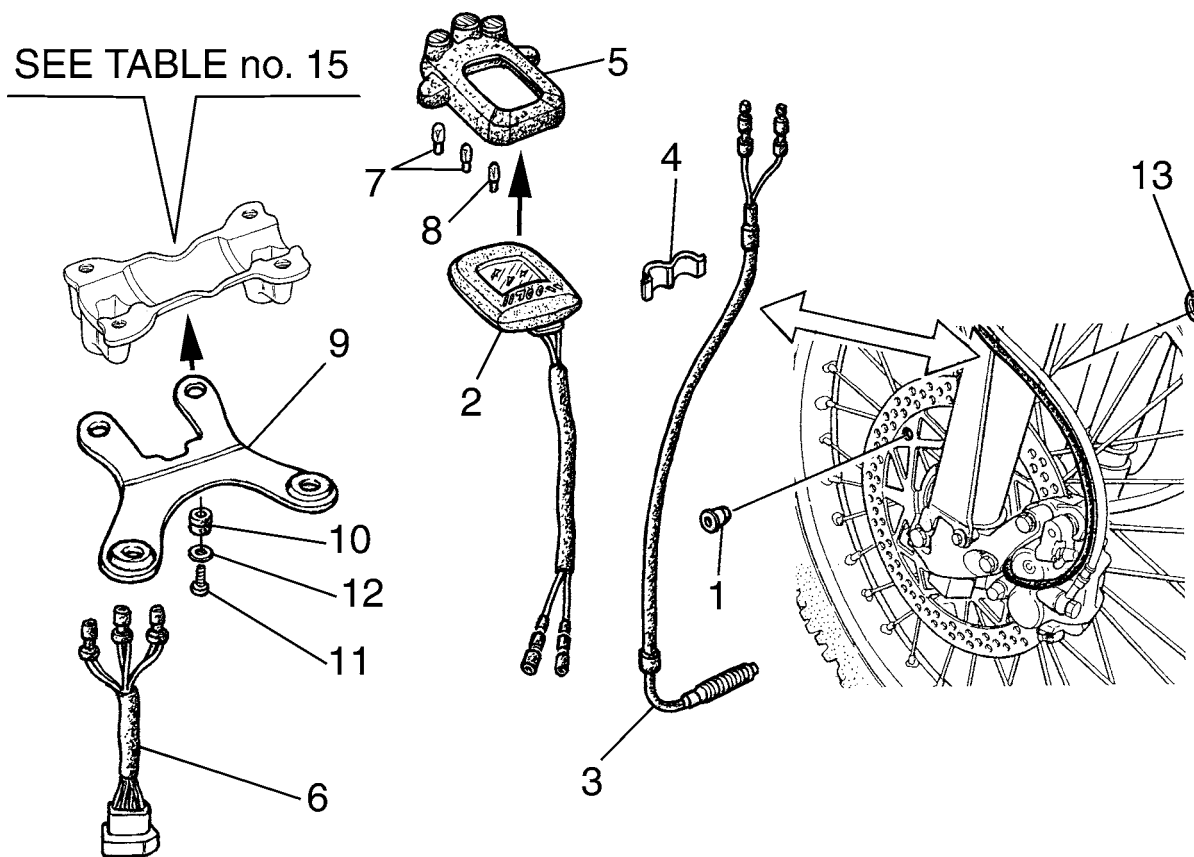

Note Notes Notas	Pos. No. Index Pos.	N. Cod. Code No. Nr. Code Code Nr N. Cod.	Q.tà Q.ty Q.te M.ge C.ad	DENOMINAZIONE	NAME	DESIGNATION	BESHREIBUNG	DENOMINACION	Validità Validity Validité Gültig Validez
X	1	8000 99775	1	Magnete	Magnet	Amiant	Magnet	Imán	
X	2	8000 99650	1	Contachilometri digitale	Digital speedometer	Compteur-km digital	Digital Tachometer	Cuenta-kilómetros digital	
X	3	8000 99652	1	Sensore magnetico	Sensor	Palpeur	Sensor	Sensor	
X	4	8000 A0664	2	Molletta	Clip	Collier	Schelle	Banda	
X	5	8000 A0883	1	Supporto spie	Holder	Support	Halterung	Soporte	
X	6	8000 99651	1	Gruppo cavi	Cable assy	Cables compl.	Kabel Kpl.	Grupo cables	
X	7	8000 20602	2	Lampadina (12V-1,2 W)	Lamp (12V-1,2 W)	Lampe (12V-1,2 W)	Lampe (12V-1,2 W)	Lamparilla (12V-1,2 W)	
X	8	8000 60033	2	Lampadina (12V-2 W)	Lamp (12V-2 W)	Lampe (12V-2 W)	Lampe (12V-2 W)	Lamparilla (12V-2 W)	
X	9	80A0 99774	1	Piastra	Plate	Plaque	Platte	Placa	
X	10	8000 41862	2	Passacavo	Fairlead	Passe-câble	Kabelführung	Prensa-cable	
X	11	8000 89069	2	Vite	Screw	Vis	Schraube	Tornillo	
X	12	62N4 15548	2	Rosetta	Washer	Rondelle	Scheibe	Arandela	
X	13	66N0 21200	1	Anello elastico	Snap ring	Bague d'arret	Haltering	Anillo elástico	

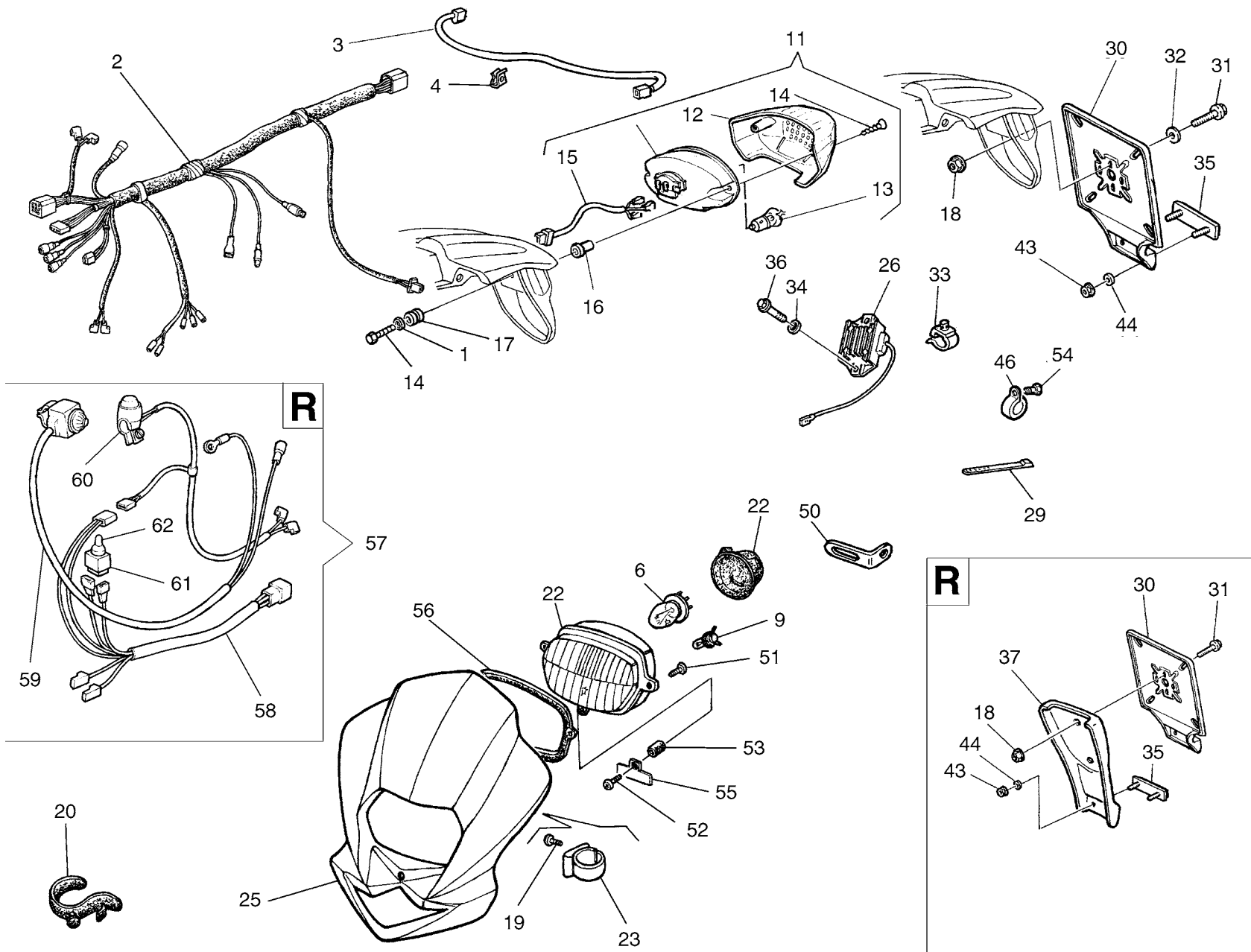

Note Notes Marke Notas	Pos. No. N. Index Pos.	N. Cod. Code No. Nr. Code Code Nr N. Cod.	Q.tà Q.ty Q.te M.ge C.ad	DENOMINAZIONE	NAME	DESIGNATION	BESHREIBUNG	DENOMINACION	Validità Validity Validité Gültig Validez
X	1	8A00 20373	2	Rosetta piana	Washer	Rondelle	Scheibe	Arandela	
X	2	8000 A0713	1	Gruppo principale cavi	Cable assy	Cables compl.	Kabel Kpl.	Grupo principal cables	
X	3	8000 70277	1	Cavo posteriore	Cable	Cable	Kabel	Cable	
X	4	8000 72494	1	Passacavo	Fairlead	Passe-câble	Kabelführung	Prensa-cable	
X	6	8000 20137	1	Lampada (12V-35/35 W)	Lamp (12V-35/35 W)	Lampe (12V-35/35 W)	Lampe (12V-35/35 W)	Lamparilla (12V-35/35 W)	
X	9	8000 26694	1	Lampada (12V-3 W)	Lamp (12V-3 W)	Lampe (12V-3 W)	Lampe (12V-3 W)	Lamparilla (12V-3 W)	
X	11	8A00 88873	1	Fanale posteriore completo	Tail light	Feux arrière	Hinterleuchte	Faro trasero	
X	12	8A00 94119	1	Lente	Lens	Loupe	Linse	Lente	
X	13	8A00 18246	1	Lampada (12V-5/12 W)	Lamp (12V-5/12 W)	Lampe (12V-5/12 W)	Lampe (12V-5/12 W)	Lamparilla (12V-5/12 W)	
X	14	8000 A0953	2	Vite	Screw	Vis	Schraube	Tornillo	
X	15	8000 94121	1	Cablaggio	Cable	Cable	Kabel	Cable	
X	16	8A00 94120	2	Distanziale	Spacer	Entretoise	Distanzstück	Separador	
X	17	8000 18048	2	Gommino	Rubber pad	Pièce caoutchouc	Gummistück	Junta de goma	
X	18	8000 44240	2	Dado	Nut	Ecrou	Mutter	Tuerca	
X	19	8A00 37283	2	Vite	Screw	Vis	Schraube	Tornillo	
X	20	8000 88602	4	Elastico	Elastic	Elastique	Elastisch	Elástico	
X	22	8000 A0278	1	Gruppo ottico	Optical group	Groupe optique	Optische Gruppe	Grupo óptico	
X	23	8000 A0864	1	Anello	Ring	Bague	Ring	Anilo	
X	25	8000 A0233	1	Cupolino	Fairing	Carenage	Verkleidung	Cúpula	
X	26	8000 75348	1	Regolatore di tensione	Voltage rectifier	Régulateur de tension	Spannungsregler	Regulador de tensión	
X	29	8000 56444	8	Fascetta (L=188 mm)	Clamp (L=188 mm)	Collier (L=188 mm)	Schelle (L=188 mm)	Banda (L=188 mm)	
X	30	8000 94595	1	Portatarga	Licence plate holder	Portebalai	Schildträger	Portamatricula	
X	31	8000 62727	2	Vite	Screw	Vis	Schraube	Tornillo	
X	32	8000 62726	2	Vite	Screw	Vis	Schraube	Tornillo	
X	33	8000 58207	2	Passacavo	Fairlead	Passe-câble	Kabelführung	Prensa-cable	
X	35	8000 73834	1	Catadiottro	Reflector	Catadioptrique	Ruckstrahler	Catafaros	
	36	8000 62728	1	Vite	Screw	Vis	Schraube	Tornillo	
RX	37	8000 94342	1	Paraspruzzi	Rear end	Terminal	Hinterkiff	Para rociada	
X	43	8000 40717	2	Dado	Nut	Ecrou	Mutter	Tuerca	
X	44	62N1 15547	2	Rosetta	Washer	Rondelle	Scheibe	Arandela	
X	46	8000 68690	1	Fascetta	Clamp	Collier	Schelle	Banda	
X	50	8AA0 55705	2	Linguetta fermacavo	Retainer	Arret	Klammer	Abrazadera de sujeción	
X	51	60N4 98033	2	Vite	Screw	Vis	Schraube	Tornillo	

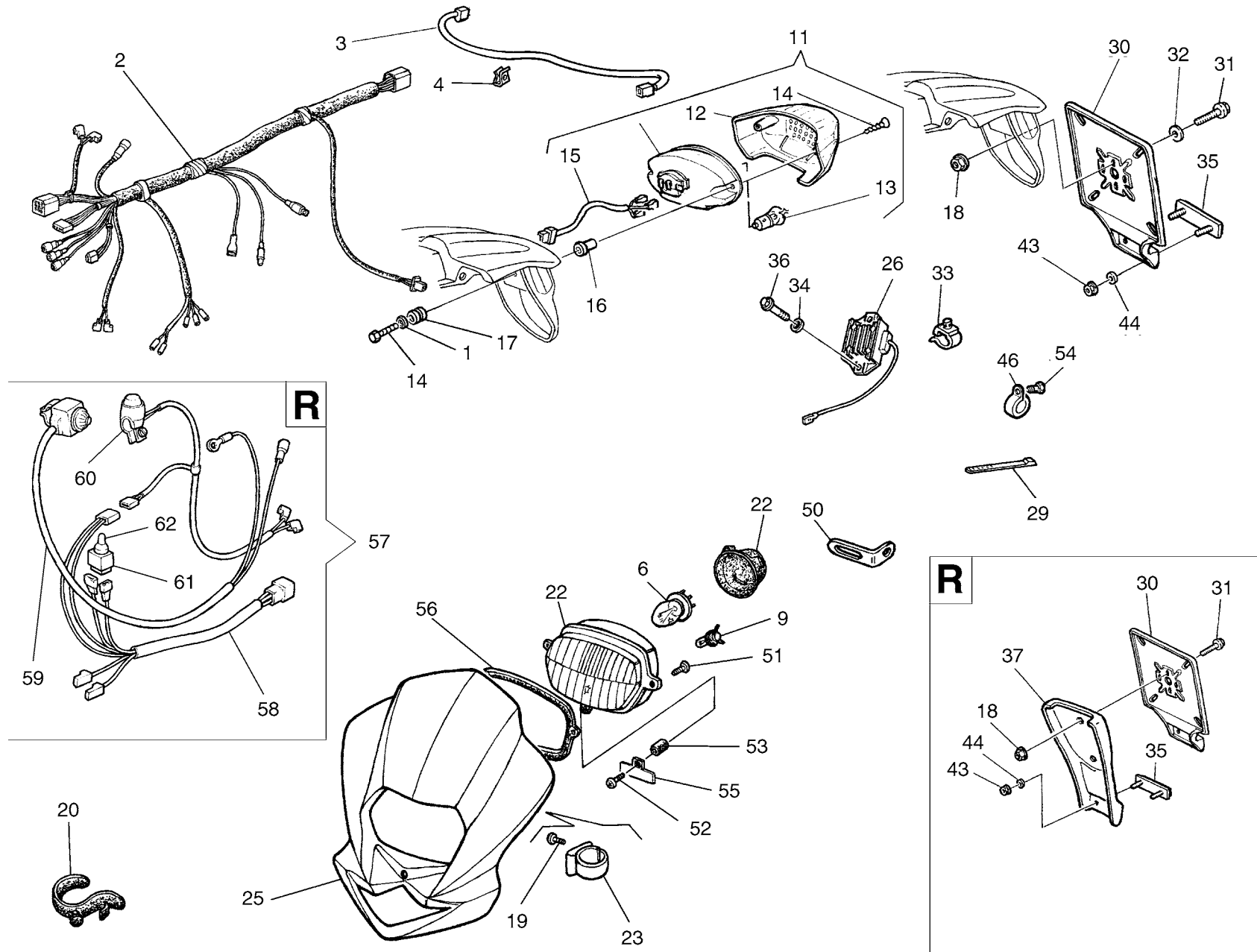



WR 250 / 2004

TAVOLA
DRAWING
TABLE
BILD
TABLA

25

IMPIANTO ELETTRICO, PORTATARGA, PORTAFARO ANTERIORE - ELECTRIC SYSTEM, PLATE HOLDER, HEADLAMP FAIRING
INSTALLATION ELECTRIQUE, PORTE-BALAI, DOME PORTE PHARE - ELEKTRISCHE ANLAGE, SCHILDTRAEGER, HUBE SCHEINWI-
HALTER - INSTALACIÓN ELECTRICA., PORTA-MATRICULA, CASQUETE PORTAFARO

Note Notes Mark Notas	Pos. No. N. Index Pos.	N. Cod. Code No. Nr. Code Code Nr N. Cod.	Q.tà Q.ty Q.te M.ge C.ad	DENOMINAZIONE	NAME	DESIGNATION	BESHREIBUNG	DENOMINACION	Validità Validity Validité Gültig Validez
X	52	8000 24962	1	Vite	Screw	Vis	Schraube	Tornillo	
X	53	8000 A1051	1	Distanziale	Spacer	Entretoise	Distanzstück	Separador	
X	54	8000 62725	1	Vite	Screw	Vis	Schraube	Tornillo	
X	55	8000 A1052	1	Piastrina	Plate	Plaque	Platte	Placa	
X	56	8000 A1053	1	Guarnizione	Gasket	Garniture	Dichtung	Junta	
RW	57	8000 A1883	1	Kit cablaggio RACING	RACING main wiring harness	Kit cables RACING	RACING Kabel Kit	Kit grupo cables RACING	
RW	58	8000 A1219	1	Cablaggio RACING	RACING wiring	Cables RACING	RACING Kabel	Cables RACING	
RW	59	8000 96828	1	Pulsante arresto motore	Engine stop button	Poussoir arret moteur	Knopf	Pùlsador parada motor	
RW	60	8000 94145	1	Pulsante avvisatore acustico	Horn button	Poussoir avertisseur acoust.	Knopf	Pùlsador avisador acustico	
RW	61	8000 93221	1	Interruttore luci	Lights switch	Poussoir feu	Schalter	Pùlsador luces	
RW	62	8000 71755	1	Cappuccio	Rubber cap	Capuchon	Gummihaube	Capuchón	

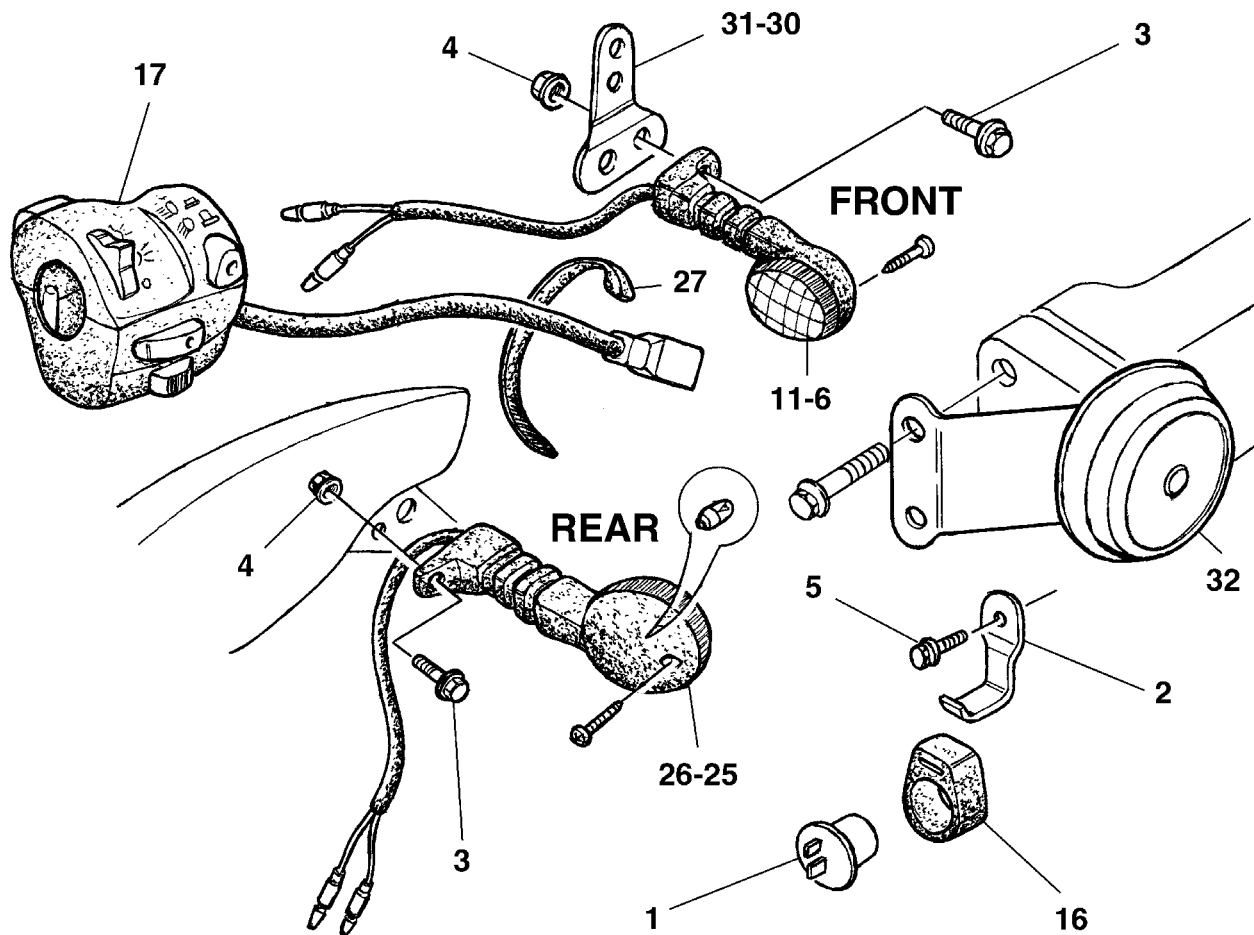

Note Notes Mark Notas	Pos. No. Index Pos.	N. Cod. Code No. Nr. Code Code Nr N. Cod.	Q.tà Q.ty Q.te M.ge C.ad	DENOMINAZIONE	NAME	DESIGNATION	BESHREIBUNG	DENOMINACION	Validità Validity Validité Gültig Validez
DX	1	8000 57511	1	Intermittenza	Flash device	Intermittence	Blinkgeber	Intermitencia	
DX	2	8000 A0678	1	Piastra per intermittenza	Plate (Flash device)	Plaque (Intermittence)	Platte (Blinkgeber)	Placa (Intermitencia)	
DX	3	8000 62727	4	Vite anteriore (M6x16 mm)	Front screw (M6x16 mm)	Vis avant (M6x16 mm)	Vord. Schraube (M6x16 mm)	Tornillo delantero (M6x16 mm)	
DX	4	8000 44240	4	Dado	Nut	Ecrou	Mutter	Tuerca	
DX	5	8000 67997	2	Vite	Screw	Vis	Schraube	Tornillo	
DX	6	8000 A0227	1	Indicatore anteriore DX	Blinker R	Clignotant D	Blinker R	Intermitente D	
DX	11	8000 A0228	1	Indicatore anteriore SX	Blinker L	Clignotant G	Blinker L	Intermitente I	
DX	16	8000 37599	1	Supporto elastico	Support	Support	Halterung	Soporte	
X	17	8000 89919	1	Commutatore compl.	Switch compl.	Commutateur compl.	Kombischalter kpl.	Conmutador compl.	
XA	17	8000 A0634	1	Commutatore compl.	Switch compl.	Commutateur compl.	Kombischalter kpl.	Conmutador compl.	
	17	8000 92149	1	Commutatore compl. (J)	Switch compl. (J)	Commutateur compl. (J)	Kombischalter kpl. (J)	Conmutador compl. (J)	
DX	25	8000 A0229	1	Indicatore posteriore DX	Blinker R	Clignotant D	Blinker R	Intermitente D	
DX	26	8000 A0230	1	Indicatore posteriore SX	Blinker L	Clignotant G	Blinker L	Intermitente I	
	27	8000 71578	2	Fascetta	Clamp	Collier	Schelle	Banda	
DX	30	8000 93011	1	Piastrina DX	R.H.Plate	Plaque D.	R. Platte	Placa D.	
DX	31	8A00 93011	1	Piastrina SX	L.H.Plate	Plaque G.	L. Platte	Placa I.	
DX	32	8000 90107	1	Avvisatore acustico	Horn	Signal acoustique	Hupe	Avisador acustico	

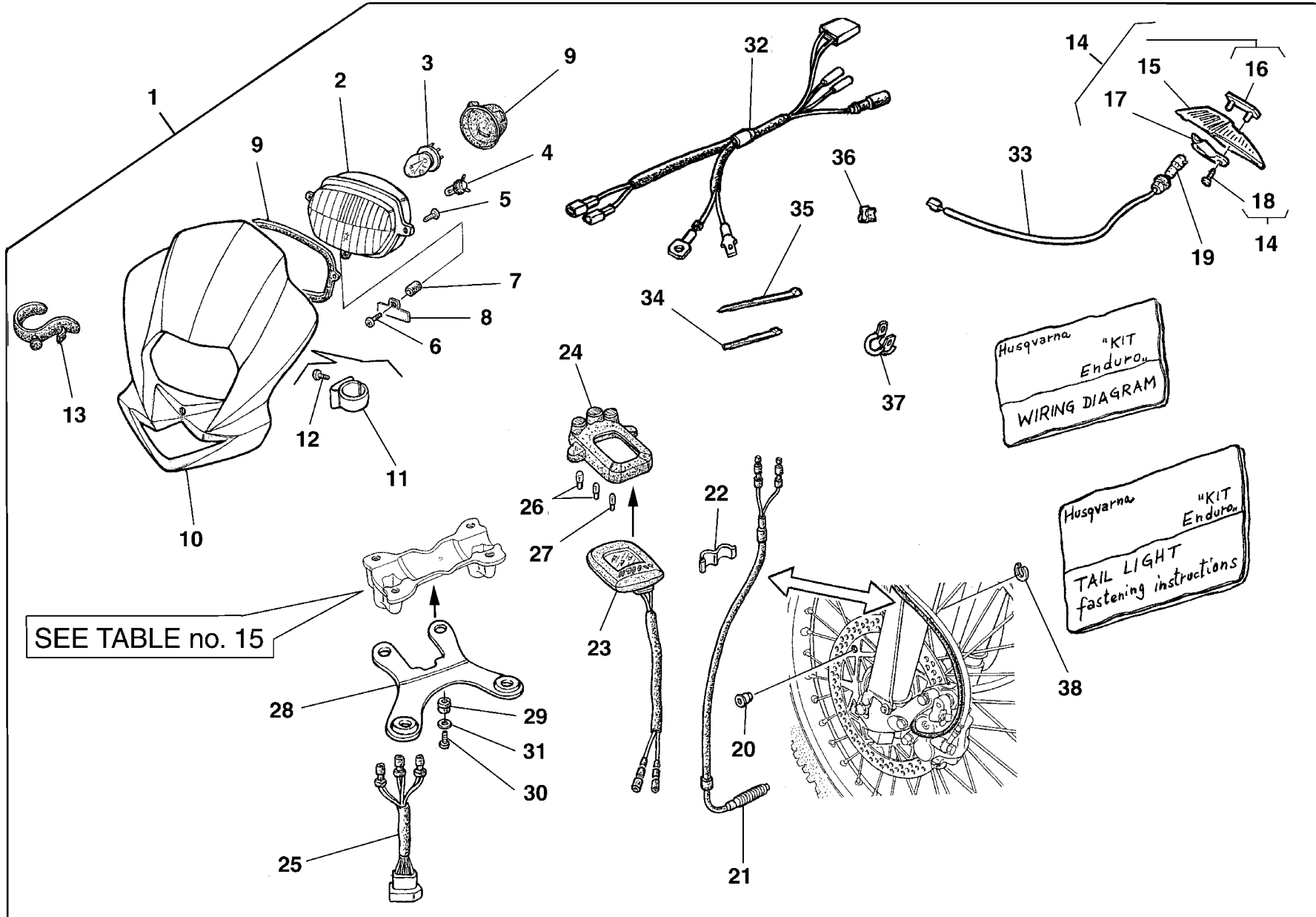

Note Notes Notes Markes Notas	Pos. No. N. Index Pos.	N. Cod. Code No. Nr. Code Code Nr N. Cod.	Q.tà Q.ty Q.te M.ge C.ad	DENOMINAZIONE	NAME	DESIGNATION	BESHREIBUNG	DENOMINACION	Validità Validity Validité Gültig Validez
	1	8000 A0495	1	Kit ENDURO	ENDURO Kit	Groupe ENDURO	Gruppe ENDURO	Kit ENDURO	
	2	8000 A0278	1	Gruppo ottico	Optical group	Groupe optique	Optische Gruppe	Grupo óptico	
	3	8000 20137	1	Lampada (12V-35/35 W)	Lamp (12V-35/35 W)	Lampe (12V-35/35 W)	Lampe (12V-35/35 W)	Lamparilla (12V-35/35 W)	
	4	8000 26694	2	Lampadina (12V-3 W)	Lamp (12V-3 W)	Lampe (12V-3 W)	Lampe (12V-3 W)	Lamparilla (12V-3 W)	
	5	60N4 98033	2	Vite	Screw	Vis	Schraube	Tornillo	
	6	60N4 24962	1	Vite	Screw	Vis	Schraube	Tornillo	
	7	8000 A1051	1	Distanziale	Spacer	Entretoise	Distanzstück	Separador	
	8	8000 A1052	1	Piastrina	Plate	Plaque	Platte	Placa	
	9	8000 A1053	1	Guarnizione	Gasket	Garniture	Dichtung	Junta	
	10	8000 A0635	1	Cupolino con decalcomania	Fairing with trim	Carenage avec decalcom.	Verkleidung mit Abziehbild	Cúpula con calcomania	
	11	8000 A0864	1	Anello	Ring	Bague	Ring	Anilo	
	12	8A00 37283	2	Vite	Screw	Vis	Schraube	Tornillo	
	13	8000 88602	4	Elastico	Elastic	Elastique	Elastisch	Elástico	
	14	8000 71213	1	Fanale posteriore completo	Tail light group	Groupe feux arrière	Hinterleuchte Gruppe	Grupo faro trasero	
	15	8000 71214	1	Fanale posteriore	Tail light	Feux arrière	Hinterleuchte	Faro trasero	
	16	8000 71215	1	Fascetta	Clamp	Collier	Schelle	Banda	
	17	8000 71216	1	Protezione	Guard	Protection	Schutz	Protección	
	18	8000 71217	2	Vite	Screw	Vis	Schraube	Tornillo	
	19	8000 26694	2	Lampadina (12V-3 W)	Lamp (12V-3 W)	Lampe (12V-3 W)	Lampe (12V-3 W)	Lamparilla (12V-3 W)	
	20	8000 99775	1	Magnete	Magnet	Amiant	Magnet	Imán	
	21	8000 99652	1	Sensore magnetico	Sensor	Palpeur	Sensor	Sensor	
	22	8000 A0664	2	Molletta	Clip	Collier	Schelle	Banda	
	23	8000 99650	1	Contachilometri digitale	Digital speedometer	Compteur-km digital	Digital Tachometer	Cuenta-kilómetros digital	
	24	8000 A0883	1	Supporto spie	Holder	Support	Halterung	Soporte	
	25	8000 99651	1	Gruppo cavi	Cable assy	Cables compl.	Kabel Kpl.	Grupo cables	
	26	8000 20602	2	Lampadina (12V-1,2 W)	Lamp (12V-1,2 W)	Lampe (12V-1,2 W)	Lampe (12V-1,2 W)	Lamparilla (12V-1,2 W)	
	27	8000 60033	2	Lampadina (12V-2 W)	Lamp (12V-2 W)	Lampe (12V-2 W)	Lampe (12V-2 W)	Lamparilla (12V-2 W)	
	28	80A0 99774	1	Piastra	Plate	Plaque	Platte	Placa	
	29	8000 41862	2	Passacavo	Fairlead	Passe-câble	Kabelführung	Prensa-cable	
	30	60N4 98033	2	Vite	Screw	Vis	Schraube	Tornillo	
	31	62N4 15547	2	Rosetta	Washer	Rondelle	Scheibe	Arandela	
	32	8000 A0492	1	Gruppo cavi (ANTERIORE)	Cable assy (FRONT)	Cables compl. (AVANT)	Kabel Kpl. (VORDERE)	Grupo cables (DELANTERO)	
	33	8000 71221	1	Gruppo cavi (POSTERIORE)	Cable assy (REAR)	Cables compl. (ARRIERE)	Kabel Kpl. (HINTERE)	Grupo cables (TRASERO)	

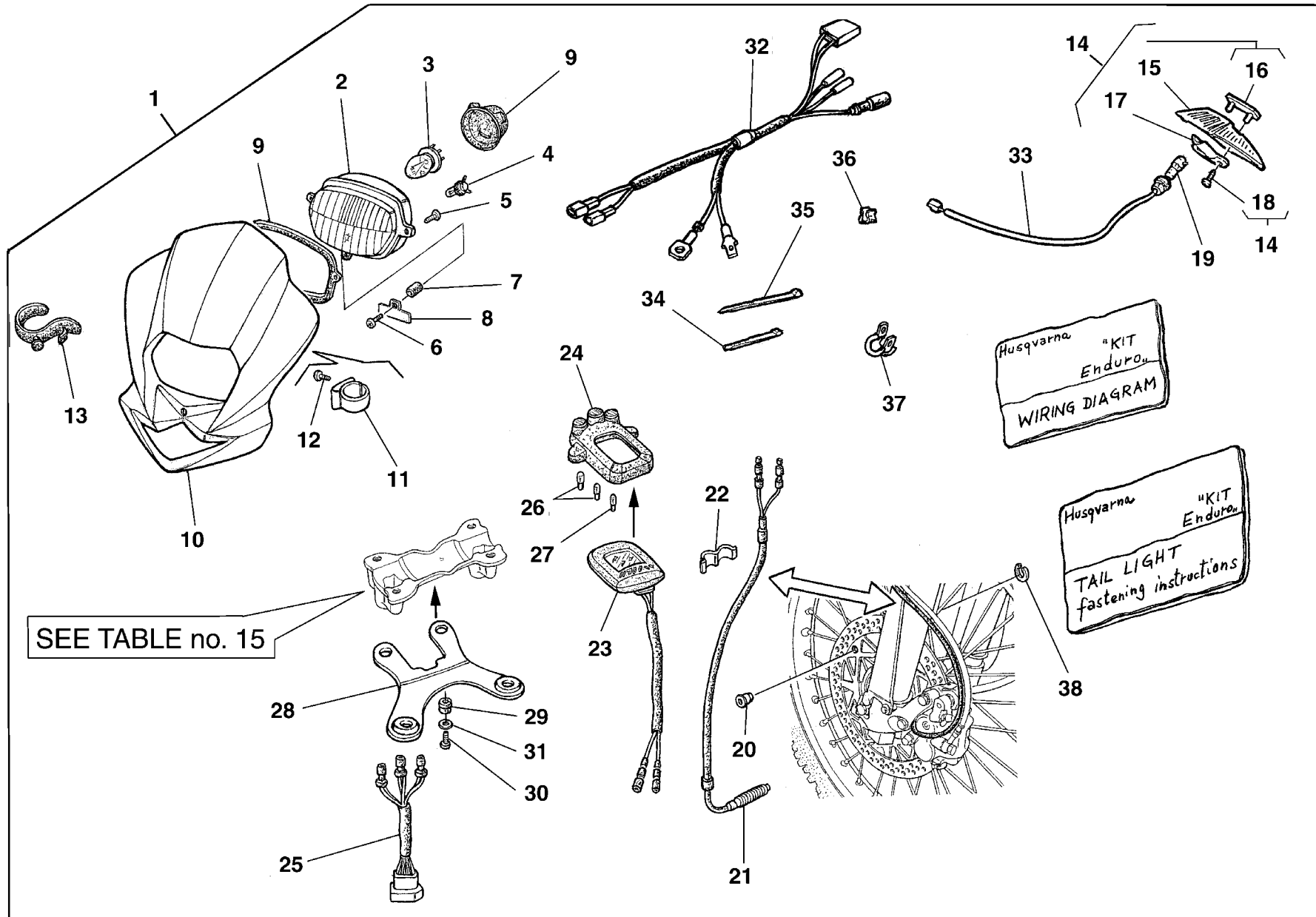



Note Notes Marke Notas	Pos. No. N. Index Pos.	N. Cod. Code No. Nr. Code Code Nr N. Cod.	Q.tà Q.ty Q.te M.ge C.ad	DENOMINAZIONE	NAME	DESIGNATION	BESHREIBUNG	DENOMINACION	Validità Validity Validité Gültig Validez
	2	8000 A3195	1	Decal per parafango anteriore	Transfer	Decalcomania	Abziehbild	Calcomania	
	3	8000 A3196	1	Decal per portafaro anteriore	Transfer	Decalcomania	Abziehbild	Calcomania	
	4	8000 A2782	1	Decal per convogliatore Dx	R.H.Transfer	Decalcomania D.	Abziehbild R.	Calcomania der.	
	5	8000 A2783	1	Decal per convogliatore Sx	L.H. transfer	Decalcomania G.	Abziehbild L.	Calcomania iz.	
	6	8000 A2778	1	Decal per fianchetto Dx	R.H.Transfer	Decalcomania D.	Abziehbild R.	Calcomania der.	
	7	8000 A2777	1	Decal per fianchetto Sx	L.H. transfer	Decalcomania G.	Abziehbild L.	Calcomania iz.	
	8	8000 A3114	1	Decal per fianchetto Dx	R.H.Transfer	Decalcomania D.	Abziehbild R.	Calcomania der.	
	9	8000 A3113	1	Decal per fianchetto Sx	L.H. transfer	Decalcomania G.	Abziehbild L.	Calcomania iz.	
	10	8000 A2820	2	Decal per forcellone	Rear swing arm transfer	Decalcomania	Abziehbild	Calcomania	
	11	8000 A2122	1	Decal per parafango posteriore	Rear fender transfer	Decalcomania	Abziehbild	Calcomania	

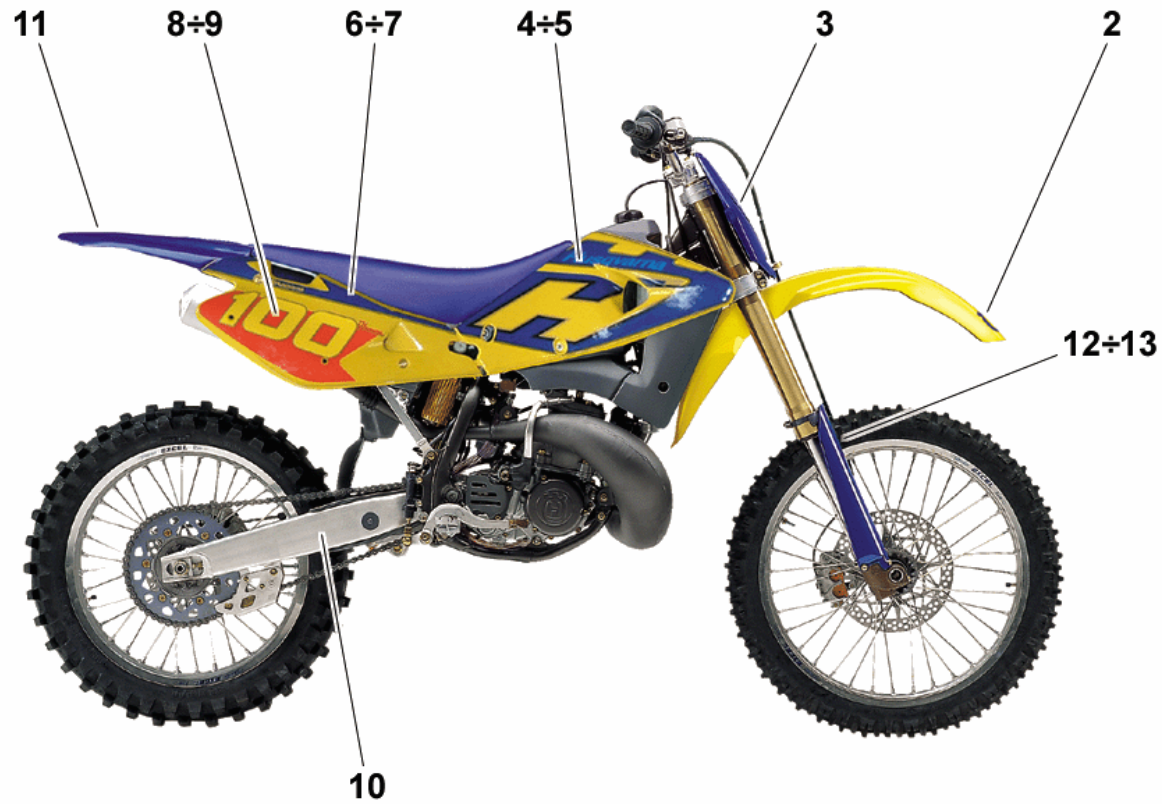

DISEGNO DRAWING DESSIN ZEICHNUNG DIBUJO	TAVOLA DRAWING TABLE BILD TABLA	INDEX NO. POS. N. INDICE	DISEGNO DRAWING DESSIN ZEICHNUNG DIBUJO	TAVOLA DRAWING TABLE BILD TABLA	INDEX NO. POS. N. INDICE	DISEGNO DRAWING DESSIN ZEICHNUNG DIBUJO	TAVOLA DRAWING TABLE BILD TABLA	INDEX NO. POS. N. INDICE	DISEGNO DRAWING DESSIN ZEICHNUNG DIBUJO	TAVOLA DRAWING TABLE BILD TABLA	INDEX NO. POS. N. INDICE	DISEGNO DRAWING DESSIN ZEICHNUNG DIBUJO	TAVOLA DRAWING TABLE BILD TABLA	INDEX NO. POS. N. INDICE	DISEGNO DRAWING DESSIN ZEICHNUNG DIBUJO	TAVOLA DRAWING TABLE BILD TABLA	INDEX NO. POS. N. INDICE
1511 33302	16A	22	66N0 21270	22A	22	8000 26694	27	19	8000 38624	7	12	8000 44978	6	4	8000 53259	18	29
1513 07001	14	25	66N0 21272	23	24	8000 27521	2	27	8000 38711	10A	13	8000 45022	6	22	8000 53259	22	20
1513 41401	21	10	6BN0 21507	7	25	8000 27690	9	6	8000 38712	10A	14	8000 45490	19	2	8000 53876	7	31
1513 74301	21	7	8000 01199	20	17	8000 27960	6	12	8000 38728	10A	12	8000 45495	16	35	8000 54073	23	4
1514 10702	21	8	8000 01412	16A	13	8000 28327	7	13	8000 38748	20	16	8000 45495	18	32	8000 54899	3	9
1515 50601	16	32	8000 01688	23	3	8000 31695	7	18	8000 38767	16A	23	8000 45495	19	33	8000 55536	7	19
1519 84701	1	9	8000 02124	5	22	8000 31717	5	12	8000 38797	17	12	8000 45495	20	10	8000 55902	18	4
1610 82301	5	33	8000 02709	3	22	8000 31772	9	5	8000 39524	1	7	8000 45499	21	18	8000 55903	18	13
1617 95501	2	15	8000 06597	5	8	8000 31773	7	15	8000 40717	25	43	8000 46225	10A	18	8000 56377	3	8
60N1 01059	16	60	8000 06597	6	2	8000 32069	7	8	8000 40718	13	8	8000 46613	1	1	8000 56377	18	6
60N1 01219	15	62	8000 07719	5	15	8000 32203	7	26	8000 40813	20	21	8000 46860	5	7	8000 56381	20	7
60N1 01883	7	21	8000 08536	16	55	8000 32388	16	56	8000 41240	20	20	8000 46893	19	5	8000 56409	5	13
60N1 02506	2	39	8000 09671	7	29	8000 32389	5	16	8000 41459	14	48	8000 47678	6	6	8000 56443	15	72
60N1 02512	5	26	8000 10777	23	3	8000 33372	13	14	8000 41862	24	10	8000 48111	7	2	8000 56444	11	22
60N1 02514	5	25	8000 11524	6	19	8000 33373	14	20	8000 41862	27	29	8000 48112	7	3	8000 56444	11	22
60N1 02515	5	24	8000 13346	22A	3	8000 34002	27	35	8000 42022	14	58	8000 48113	7	4	8000 56444	25	29
60N1 04134	20	2	8000 17810	16	21	8000 34083	4	3	8000 42022	16A	16	8000 48114	7	5	8000 56444	27	34
60N1 15033	8	26	8000 17826	2	4	8000 34451	6	8	8000 42022	16B	31	8000 48115	7	7	8000 56462	4	17
60N4 24962	27	6	8000 18048	25	17	8000 35099	6	23	8000 42023	11	5	8000 48116	7	9	8000 56767	23	28
60N4 98033	25	51	8000 19177	6	7	8000 35531	14	34	8000 42023	16A	15	8000 48117	7	10	8000 56920	1	23
60N4 98033	27	5	8000 19620	6	21	8000 35780	3	36	8000 42023	16A	17	8000 48125	10A	9	8000 57155	18	24
60N4 98033	27	30	8000 19965	4	6	8000 35780	8	23	8000 42100	5	9	8000 48127	10A	11	8000 57155	18	26
62N1 15504	11	9	8000 19979	5	31	8000 35781	3	37	8000 42155	5	2	8000 48138	8	4	8000 57155	22	23
62N1 15504	14	49	8000 20137	25	6	8000 36137	16	40	8000 42185	5	14	8000 48209	5	21	8000 57205	4	27
62N1 15547	13	15	8000 20137	27	3	8000 36440	5	5	8000 42244	5	29	8000 48212	5	6	8000 57511	26	1
62N1 15547	25	44	8000 20474	7	20	8000 36467	20	9	8000 42278	3	10	8000 48216	6	9	8000 57542	7	14
62N1 15549	13	10	8000 20536	16	14	8000 36786	6	11	8000 42349	18	21	8000 48234	8	29	8000 58207	25	33
62N4 15547	27	31	8000 20536	16	61	8000 36856	8	9	8000 43391	14	29	8000 48235	8	27	8000 58256	1	2
62N4 15548	24	12	8000 20602	24	7	8000 36856	8	13	8000 43592	20	18	8000 48236	8	28	8000 58258	1	3
64N1 20048	14	50	8000 20602	27	26	8000 36857	8	10	8000 43720	1	4	8000 48238	8	14	8000 58394	6	29
64N1 20068	14	12	8000 21375	3	7	8000 36888	9	15	8000 43789	5	30	8000 48239	8	17	8000 58394	11	23
64N1 20068	18	7	8000 21480	18	25	8000 37599	26	16	8000 43823	1	13	8000 48814	19	23	8000 59289	16	24
65N0 21002	11	4	8000 21480	22	24	8000 37745	20	15	8000 43824	1	5	8000 48856	5	27	8000 59433	14	38
65N0 21010	8	15	8000 21810	12	24	8000 38110	7	23	8000 43928	14	31	8000 48916	17	16	8000 59434	14	40
66N0 21200	24	13	8000 22373	9	20	8000 38215	6	5	8000 43928	16	37	8000 48917	17	5	8000 59801	4	15
66N0 21200	27	38	8000 22551	18	3	8000 38291	11	9	8000 43928	16	44	8000 48966	17	24	8000 59803	4	12
66N0 21202	7	28	8000 22966	22A	23	8000 38350	8	8	8000 43928	23	18	8000 49016	5	28	8000 59843	4	1
66N0 21202	10A	17	8000 23110	9	25	8000 38518	5	19	8000 44240	11	14	8000 49036	22A	4	8000 59844	4	2
66N0 21205	7	17	8000 24952	5	4	8000 38520	10A	4	8000 44240	16	33	8000 49654	22	16	8000 59845	4	4
66N0 21207	7	6	8000 24962	25	52	8000 38521	16A	12	8000 44240	16	46	8000 50005	20	27	8000 59977	5	3
66N0 21208	7	11	8000 25044	8	16	8000 38622	7	27	8000 44240	21	21	8000 50629	2	3	8000 59977	5	18
66N0 21209	9	10	8000 26694	25	9	8000 38623	7	30	8000 44240	25	18	8000 50798	17	10	8000 60033	24	8
66N0 21211	9	22	8000 26694	27	4	8000 38624	2	18	8000 44240	26	4	8000 53155	15	61	8000 60033	27	27

DISEGNO DRAWING DESSIN ZEICHNUNG DIBUJO	TAVOLA DRAWING TABLE BILD TABLA	INDEX NO. POS. N. INDICE	DISEGNO DRAWING DESSIN ZEICHNUNG DIBUJO	TAVOLA DRAWING TABLE BILD TABLA	INDEX NO. POS. N. INDICE	DISEGNO DRAWING DESSIN ZEICHNUNG DIBUJO	TAVOLA DRAWING TABLE BILD TABLA	INDEX NO. POS. N. INDICE	DISEGNO DRAWING DESSIN ZEICHNUNG DIBUJO	TAVOLA DRAWING TABLE BILD TABLA	INDEX NO. POS. N. INDICE	DISEGNO DRAWING DESSIN ZEICHNUNG DIBUJO	TAVOLA DRAWING TABLE BILD TABLA	INDEX NO. POS. N. INDICE	DISEGNO DRAWING DESSIN ZEICHNUNG DIBUJO	TAVOLA DRAWING TABLE BILD TABLA	INDEX NO. POS. N. INDICE
8000 60233	15	59	8000 62728	6	26	8000 67997	16	57	8000 71214	27	15	8000 75270	11	11	8000 86140	16A	18
8000 60234	15	60	8000 62728	8	1	8000 67997	26	5	8000 71215	27	16	8000 75330	17	4	8000 86176	16A	3
8000 60464	9	24	8000 62728	10A	28	8000 68690	25	46	8000 71216	27	17	8000 75343	11	17	8000 86176	16A	10
8000 60516	1	1	8000 62728	13	13	8000 68690	27	37	8000 71217	27	18	8000 75346	11	7	8000 86177	16A	7
8000 60873	4	28	8000 62728	17	14	8000 69035	20	26	8000 71221	27	33	8000 75348	25	26	8000 86177	16A	26
8000 60944	9	3	8000 62728	17	17	8000 69036	20	5	8000 71445	18	27	8000 75578	1	10	8000 86806/1	2	9
8000 60947	9	7	8000 62728	19	18	8000 69056	14	3	8000 71445	22	14	8000 75579	1	10	8000 86806/2	2	9
8000 60951	9	17	8000 62728	25	36	8000 69056	14	51	8000 71578	17	26	8000 76016	11	10	8000 86806/3	2	9
8000 61068	17	22	8000 62729	2	25	8000 69111	14	21	8000 71578	26	27	8000 76283	16	11	8000 86817	2	7
8000 61078	18	14	8000 62729	4	14	8000 69113	21	19	8000 71620	16	13	8000 76338	18	10	8000 86819	2	8
8000 61102	2	22	8000 62729	6	10	8000 69125	18	2	8000 71621	16	53	8000 76687	17	3	8000 86823	2	12
8000 61313	19	4	8000 62729	15	40	8000 69148	19	15	8000 71622	16	2	8000 76688	17	2	8000 86825	2	19
8000 61314	15	63	8000 62729	22	37	8000 69149	19	7	8000 71623	16	19	8000 77373	15	20	8000 86827	2	20
8000 61355	15	53	8000 62730	3	21	8000 69150	14	18	8000 71755	25	62	8000 77737	17	11	8000 86828	2	21
8000 62341	21	1	8000 62730	21	6	8000 69282	15	69	8000 71806	22	10	8000 78788	5	17	8000 86840	3	5
8000 62675	14	55	8000 62731	16	29	8000 69282	16	52	8000 72022	22	13	8000 79065	22	21	8000 86843	3	6
8000 62676	14	54	8000 62731	16	45	8000 69315	15	57	8000 72168	16A	21	8000 79066	18	22	8000 86844	3	23
8000 62725	4	34	8000 62732	14	51	8000 69372	6	16	8000 72318	12	20	8000 79066	22	22	8000 86846	3	17
8000 62725	11	13	8000 62733	22	12	8000 69429	13	5	8000 72323	12	9	8000 79072	18	16	8000 86847	3	14
8000 62725	16	47	8000 62795	14	4	8000 69429	16B	23	8000 72327	12	13	8000 79075	18	28	8000 86848	3	25
8000 62725	18	18	8000 62795	16	36	8000 69429	19	17	8000 72328	12	14	8000 79077	4	10	8000 86849	3	19
8000 62725	21	20	8000 62796	14	19	8000 69429	19	21	8000 72329	12	15	8000 79099	22	7	8000 86850	3	20
8000 62725	25	54	8000 62796	15	2	8000 69429	19	22	8000 72331	12	17	8000 79789	23	28	8000 86851	2	24
8000 62726	13	9	8000 63312	14	39	8000 69429	20	23	8000 72494	25	4	8000 79790	23	28	8000 86860	8	12
8000 62726	16B	24	8000 63312	16	54	8000 69434	14	7	8000 72494	27	36	8000 80145	11	20	8000 86864	3	28
8000 62726	18	33	8000 63828	9	22	8000 69549	13	2	8000 72522	5	23	8000 80208	18	31	8000 86865	3	29
8000 62726	19	27	8000 63829	9	22	8000 69750	3	27	8000 72641	13	3	8000 80260	15	54	8000 86866	3	31
8000 62726	19	32	8000 63830	9	22	8000 70024	13	7	8000 72868	16	42	8000 81628	16	63	8000 86867	3	32
8000 62726	21	17	8000 63885	2	35	8000 70215	10A	7	8000 72869	16	41	8000 82496	11	2	8000 86868	3	33
8000 62726	23	15	8000 64988	4	33	8000 70216	10A	8	8000 72873	16	5	8000 82928	9	19	8000 86872	5	1
8000 62726	25	32	8000 64988	6	30	8000 70217	10A	27	8000 72874	16	28	8000 82929	9	13	8000 86878	6	25
8000 62727	3	30	8000 65411	16	31	8000 70277	25	3	8000 72875	16	27	8000 82931	9	18	8000 86880	8	3
8000 62727	6	14	8000 65412	16	9	8000 70638	18	35	8000 72887	11	7	8000 82939	6	13	8000 86884	9	1
8000 62727	11	2	8000 65437	17	21	8000 70696	18	5	8000 73140	14	5	8000 82943	3	18	8000 86885	9	2
8000 62727	11	15	8000 65442	23	27	8000 70698	17	18	8000 73458	14	27	8000 83395	15	3	8000 86886	9	9
8000 62727	18	12	8000 65464	23	28	8000 70836	1	16	8000 73500	5	11	8000 84176	14	56	8000 86887	4	22
8000 62727	19	11	8000 66238	20	3	8000 71007	10A	29	8000 73540	11	5	8000 84938	22A	13	8000 86888	13	6
8000 62727	19	14	8000 66651	14	47	8000 71008	10A	30	8000 73593	11	8	8000 85220	17	23	8000 86902	2	11
8000 62727	20	24	8000 66652	14	45	8000 71009	10A	31	8000 73832	16	62	8000 85390	8	7	8000 86907	12	1
8000 62727	25	31	8000 66802	1	17	8000 71010	10A	32	8000 73834	25	35	8000 85395	10A	2	8000 86918	12	2
8000 62727	26	3	8000 67997	3	26	8000 71088	14	44	8000 74016	16	38	8000 85932	18	30	8000 86920	12	5
8000 62728	3	16	8000 67997	15	68	8000 71091	14	22	8000 75160	16	51	8000 86136	16A	5	8000 86921	12	6
8000 62728	6	18	8000 67997	16	14	8000 71213	27	14	8000 75166	16	39	8000 86137	16A	20	8000 86925	12	10

DISEGNO DRAWING DESSIN ZEICHNUNG DIBUJO	TAVOLA DRAWING TABLE BILD TABLA	INDEX NO. POS. N. INDICE	DISEGNO DRAWING DESSIN ZEICHNUNG DIBUJO	TAVOLA DRAWING TABLE BILD TABLA	INDEX NO. POS. N. INDICE	DISEGNO DRAWING DESSIN ZEICHNUNG DIBUJO	TAVOLA DRAWING TABLE BILD TABLA	INDEX NO. POS. N. INDICE	DISEGNO DRAWING DESSIN ZEICHNUNG DIBUJO	TAVOLA DRAWING TABLE BILD TABLA	INDEX NO. POS. N. INDICE	DISEGNO DRAWING DESSIN ZEICHNUNG DIBUJO	TAVOLA DRAWING TABLE BILD TABLA	INDEX NO. POS. N. INDICE	DISEGNO DRAWING DESSIN ZEICHNUNG DIBUJO	TAVOLA DRAWING TABLE BILD TABLA	INDEX NO. POS. N. INDICE
8000 86926	12	11	8000 89998	7	24	8000 93750	17	13	8000 96960	16	3	8000 98785	15	81	8000 A0320	10A	15
8000 86927	12	12	8000 90012	11	12	8000 93751	17	8	8000 96997	1	18	8000 98786	15	6	8000 A0322	10A	6
8000 86928	12	16	8000 90104	22	13	8000 93752	17	29	8000 97025	16	58	8000 98787	15	5	8000 A0323	10A	21
8000 86929	12	22	8000 90107	26	32	8000 93883	20	11	8000 97034	15	50	8000 98791	15	21	8000 A0324	10A	23
8000 86930	12	23	8000 90561	16A	24	8000 94009	20	19	8000 97035	15	49	8000 98792	15	22	8000 A0336	8	20
8000 86932	12	7	8000 90617	7	1	8000 94010	20	13	8000 97036	16	1	8000 98806	15	41	8000 A0339	20	18
8000 86933	12	21	8000 90659	1	12	8000 94098	20	8	8000 97038	16B	1	8000 99632	22A	16	8000 A0350	14	2
8000 86978	12	8	8000 90710	17	7	8000 94117	4	18	8000 97137	8	12	8000 99650	24	2	8000 A0491	21	11
8000 86979	12	18	8000 91238	16B	4	8000 94121	25	15	8000 97152	16B	1	8000 99650	27	23	8000 A0492	27	32
8000 86980	10A	10	8000 91288	1	14	8000 94125	22	3	8000 97233	2	10	8000 99651	24	6	8000 A0495	27	1
8000 86990	9	8	8000 91289	1	15	8000 94126	22	4	8000 97234	2	13	8000 99651	27	25	8000 A0545	19	12
8000 86991	9	16	8000 91474	15	13	8000 94127	22	5	8000 97252	3	11	8000 99652	24	3	8000 A0546	19	12
8000 86994	9	11	8000 91479	15	19	8000 94128	22	6	8000 97615	1	24	8000 99652	27	21	8000 A0590	10A	22
8000 86995	9	12	8000 91480	15	48	8000 94145	25	60	8000 97749	15	77	8000 99674	22	11	8000 A0600	22	8
8000 87243	14	25	8000 91519	15	55	8000 94342	25	37	8000 97750	15	76	8000 99715	22	1	8000 A0610	8	19
8000 87736	15	56	8000 91610	15	21	8000 94595	25	30	8000 97976	14	53	8000 99729	18	15	8000 A0633	15	51
8000 87745	15	73	8000 91719	3	35	8000 94849	18	26	8000 98040	14	52	8000 99775	24	1	8000 A0634	26	17
8000 87765	2	6	8000 91952	11	1	8000 94853	2	28	8000 98118	15	64	8000 99775	27	20	8000 A0635	27	10
8000 87810	16	10	8000 91953	11	17	8000 95260	15	41	8000 98149	10A	5	8000 99819	8	11	8000 A0664	24	4
8000 87812	17	15	8000 91962	11	21	8000 95898	13	4	8000 98237	15	58	8000 99859	22	38	8000 A0664	27	22
8000 88231	16B	21	8000 92149	26	17	8000 96811	15	1	8000 98489	16B	5	8000 99891	2	29	8000 A0678	26	2
8000 88280	17	1	8000 92215	4	8	8000 96813	15	4	8000 98490	16B	7	8000 99893	2	32	8000 A0692	23	14
8000 88602	25	20	8000 92216	4	9	8000 96828	17	25	8000 98491	16B	8	8000 99895	2	10	8000 A0693	23	29
8000 88602	27	13	8000 92225	3	24	8000 96828	25	59	8000 98492	16B	9	8000 99896	2	13	8000 A0713	25	2
8000 88862	20	1	8000 92248	11	24	8000 96830	22	2	8000 98493	16B	10	8000 99901	2	29	8000 A0802	2	24
8000 88862	20	1	8000 92308	17	9	8000 96830	22	2	8000 98494	16B	12	8000 A0050	19	1	8000 A0803	2	19
8000 88863	18	23	8000 92414	23	9	8000 96831	22	1	8000 98495	16B	20	8000 A0051	19	24	8000 A0864	25	23
8000 88865	17	6	8000 92788	21	5	8000 96838	22A	10	8000 98496	16B	15	8000 A0080	22A	8	8000 A0864	27	11
8000 88877	20	1	8000 92797	22A	12	8000 96897	15	4	8000 98497	16B	16	8000 A0081	22A	9	8000 A0872	4	25
8000 88877	20	1	8000 92797	23	11	8000 96907	14	6	8000 98498	16B	17	8000 A0085	23	6	8000 A0883	24	5
8000 88966	8	5	8000 93009	21	11	8000 96908	14	11	8000 98499	16B	18	8000 A0086	23	7	8000 A0883	27	24
8000 88969	10A	26	8000 93011	26	30	8000 96922	16A	1	8000 98500	16B	2	8000 A0144	21	23	8000 A0927	22	9
8000 89024	2	1	8000 93017	20	12	8000 96923	16A	2	8000 98501	16B	13	8000 A0227	26	6	8000 A0929	22	15
8000 89025	2	37	8000 93023	21	11	8000 96928	22A	11	8000 98502	16B	14	8000 A0228	26	11	8000 A0930	22	25
8000 89026	2	38	8000 93036	22	8	8000 96930	22A	21	8000 98503	16B	19	8000 A0229	26	25	8000 A0931	18	19
8000 89069	24	11	8000 93072	23	21	8000 96932	22A	18	8000 98507	16B	3	8000 A0230	26	26	8000 A0931	22	19
8000 89089	16B	11	8000 93124	16A	6	8000 96933	22A	19	8000 98511	16B	3	8000 A0233	25	25	8000 A0932	22	18
8000 89353	6	28	8000 93221	25	61	8000 96934	22	17	8000 98552	15	22	8000 A0241	19	28	8000 A0935	18	34
8000 89572	23	26	8000 93283	15	70	8000 96937	23	8	8000 98569	16B	6	8000 A0278	25	22	8000 A0936	18	17
8000 89919	26	17	8000 93746	17	20	8000 96938	23	12	8000 98570	16B	6	8000 A0278	27	2	8000 A0953	25	14
8000 89954	2	31	8000 93747	17	19	8000 96940	23	19	8000 98782	15	78	8000 A0316	10A	1	8000 A1051	25	53
8000 89957	3	12	8000 93748	17	27	8000 96941	16	50	8000 98783	15	79	8000 A0317	5	7	8000 A1051	27	7
8000 89996	7	22	8000 93749	17	28	8000 96944	16	18	8000 98784	15	80	8000 A0318	10A	25	8000 A1052	25	55

DISEGNO DRAWING DESSIN ZEICHNUNG DIBUJO	TAVOLA DRAWING TABLE BILD TABLA	INDEX NO. POS. N. INDICE	DISEGNO DRAWING DESSIN ZEICHNUNG DIBUJO	TAVOLA DRAWING TABLE BILD TABLA	INDEX NO. POS. N. INDICE	DISEGNO DRAWING DESSIN ZEICHNUNG DIBUJO	TAVOLA DRAWING TABLE BILD TABLA	INDEX NO. POS. N. INDICE	DISEGNO DRAWING DESSIN ZEICHNUNG DIBUJO	TAVOLA DRAWING TABLE BILD TABLA	INDEX NO. POS. N. INDICE	DISEGNO DRAWING DESSIN ZEICHNUNG DIBUJO	TAVOLA DRAWING TABLE BILD TABLA	INDEX NO. POS. N. INDICE	DISEGNO DRAWING DESSIN ZEICHNUNG DIBUJO	TAVOLA DRAWING TABLE BILD TABLA	INDEX NO. POS. N. INDICE
8000 A1052	27	8	80A0 89953	14	9	8A00 67545	6	3	8A00 A0144	21	23	8D00 96837	23	16			
8000 A1053	25	56	80A0 89962	14	10	8A00 67545	20	4	8AA0 55705	4	29	8E00 07989	9	21			
8000 A1053	27	9	80A0 91792	13	1	8A00 67997	15	52	8AA0 55705	25	50	8E00 32069	7	8			
8000 A1137	22	39	80A0 99774	24	9	8A00 67997	16	23	8AB0 88866	19	9	8E00 67545	2	23			
8000 A1219	25	58	80A0 99774	27	28	8A00 69282	16	26	8AB0 88867	19	10	8E00 67997	6	27			
8000 A1589	19	3	80B0 73832	15	82	8A00 69315	15	57	8AB0 88868	20	6	8E00 97069	14	1			
8000 A1804	12	4	80B0 82930	6	17	8A00 71086	14	37	8AB0 88869	20	22	8E00 99475	13	12			
8000 A1856	2	29	80B0 82940	4	5	8A00 71087	14	46	8B00 06725	6	20	8F00 67997	3	15			
8000 A1883	25	57	80B0 87800	19	29	8A00 72334	12	19	8B00 26846	23	10	8G00 07989	9	21			
8000 A2122	28	11	80B0 96560	6	24	8A00 73340	4	20	8B00 38110	7	23	8H00 67545	5	10			
8000 A2122	29	11	80G0 69337	15	66	8A00 73343	18	1	8B00 42700	3	3	8I00 07989	9	21			
8000 A2352	16	64	80G0 69338	15	67	8A00 73541	21	3	8B00 43715	4	11	8K00 69056	2	14			
8000 A2777	28	7	8A00 01815	14	13	8A00 75347	11	1	8B00 46226	10A	19	8L00 66179	18	20			
8000 A2777	29	7	8A00 18246	25	13	8A00 76026	18	9	8B00 48239	8	17	8L00 A1804	12	4			
8000 A2778	28	6	8A00 20373	25	1	8A00 79072	18	16	8B00 57446	11	10	8M00 A1804	12	4			
8000 A2778	29	6	8A00 22551	3	34	8A00 79783	23	27	8B00 64988	2	36	8N00 73458	14	28			
8000 A2782	28	4	8A00 26846	23	20	8A00 79785	23	27	8B00 66525	15	71	8S00 68873	20	25			
8000 A2782	29	4	8A00 28327	5	20	8A00 82467	8	6	8B00 67545	4	7	8T00 72310	12	3			
8000 A2783	28	5	8A00 28327	10A	24	8A00 86136	16A	19	8B00 69282	19	26	8U00 72310	12	3			
8000 A2783	29	5	8A00 30729	2	5	8A00 86138	16A	4	8B00 86902	2	11	8V00 72310	12	3			
8000 A2820	28	10	8A00 31970	21	2	8A00 86176	16A	11	8B00 86918	12	2	8W00 72310	12	3			
8000 A2820	29	10	8A00 36889	9	14	8A00 86845	3	13	8B00 86920	12	5	8X00 72310	12	3			
8000 A2824	29	10	8A00 37283	25	19	8A00 86902	2	11	8B00 96837	23	16	8Y00 72310	12	3			
8000 A2953	1	19	8A00 37283	27	12	8A00 86918	12	2	8B00 99475	4	16	8Z00 72310	12	3			
8000 A2954	1	20	8A00 37947	13	11	8A00 86920	12	5	8B00 99475	4	21						
8000 A2955	1	22	8A00 38110	7	16	8A00 87717	15	3	8B00 A0144	21	23						
8000 A3113	28	9	8A00 39248	8	2	8A00 87810	16	10	8B00 A1804	12	4						
8000 A3113	29	9	8A00 44117	2	17	8A00 88873	25	11	8B00 A1804	12	4						
8000 A3114	28	8	8A00 48239	8	17	8A00 92986	22A	15	8C00 40796	23	17						
8000 A3114	29	8	8A00 50632	2	2	8A00 93011	26	31	8C00 61121	16	20						
8000 A3191	15	7	8A00 53504	22A	6	8A00 94119	25	12	8C00 67997	19	25						
8000 A3195	28	2	8A00 54319	9	4	8A00 94120	25	16	8C00 69056	15	65						
8000 A3195	29	2	8A00 55241	18	11	8A00 94356	14	57	8C00 70379	21	9						
8000 A3196	28	3	8A00 55241	22A	17	8A00 96811	15	1	8C00 86138	16A	14						
8000 A3196	29	3	8A00 55860	23	5	8A00 96837	23	16	8C00 86902	2	11						
8000 A3197	29	13	8A00 56768	23	27	8A00 97029	14	1	8C00 86920	12	5						
8000 A3198	29	12	8A00 58929	23	5	8A00 97069	14	1	8C00 96837	23	16						
80A0 42349	20	14	8A00 62795	16	43	8A00 97148	15	50	8D00 01261	10A	20						
80A0 69551	16B	22	8A00 62797	14	4	8A00 97149	15	49	8D00 32069	7	8						
80A0 73426	16	16	8A00 62797	16B	30	8A00 97739	10A	3	8D00 38110	7	16						
80A0 73456	16	15	8A00 63593	2	16	8A00 97977	14	53	8D00 59802	4	13						
80A0 74388	16	22	8A00 65503	15	56	8A00 99475	4	19	8D00 62797	16A	8						
80A0 86875	6	1	8A00 66661	16	34	8A00 A0085	23	6	8D00 86918	12	2						

**CATALOGO PARTI DI RICAMBIO - PARTS CATALOG
CATALOGUE PIECES DE RECHANGE - ERSATZTEILKATALOG
CATALOGO PIEZAS DE REPUESTO**

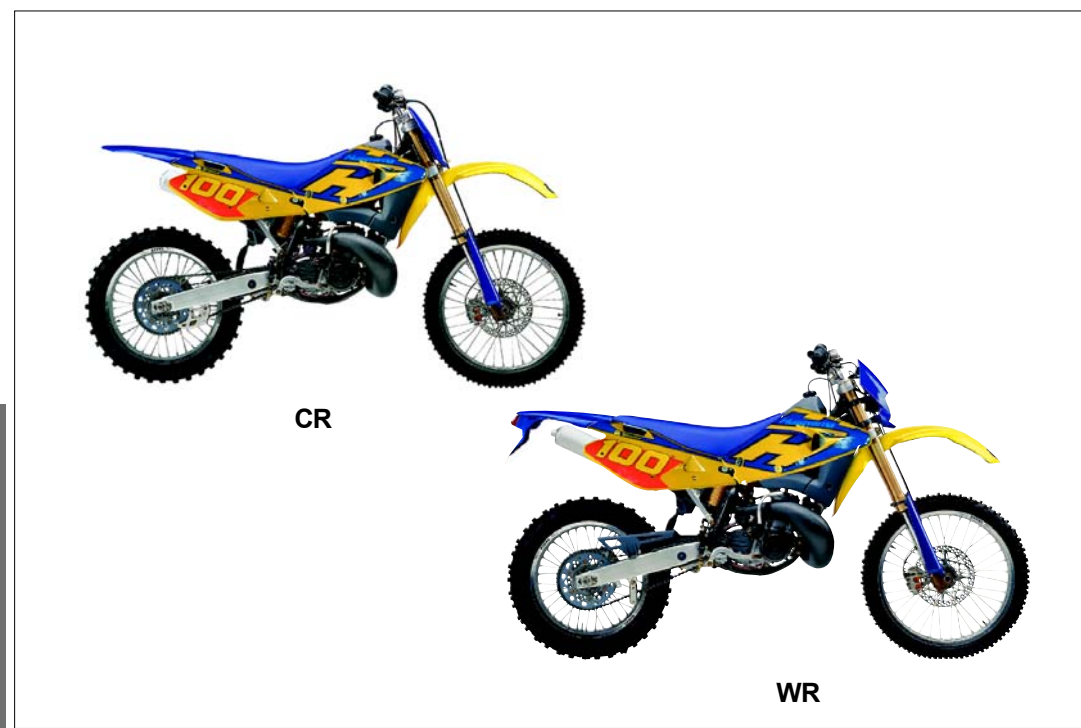

CR-WR 250 / 2004

Part. N° 8000 A2955